

Samchully Machinery
General Catalog Vol.9

www.samchully.com

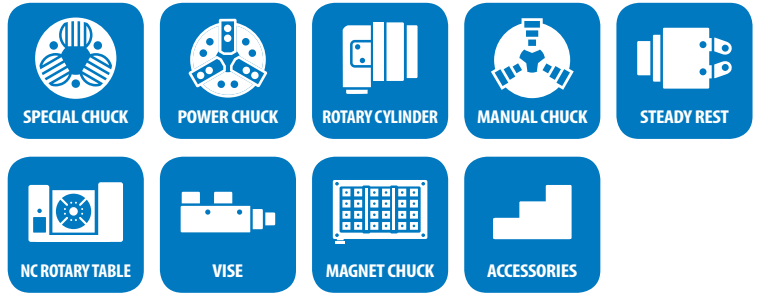

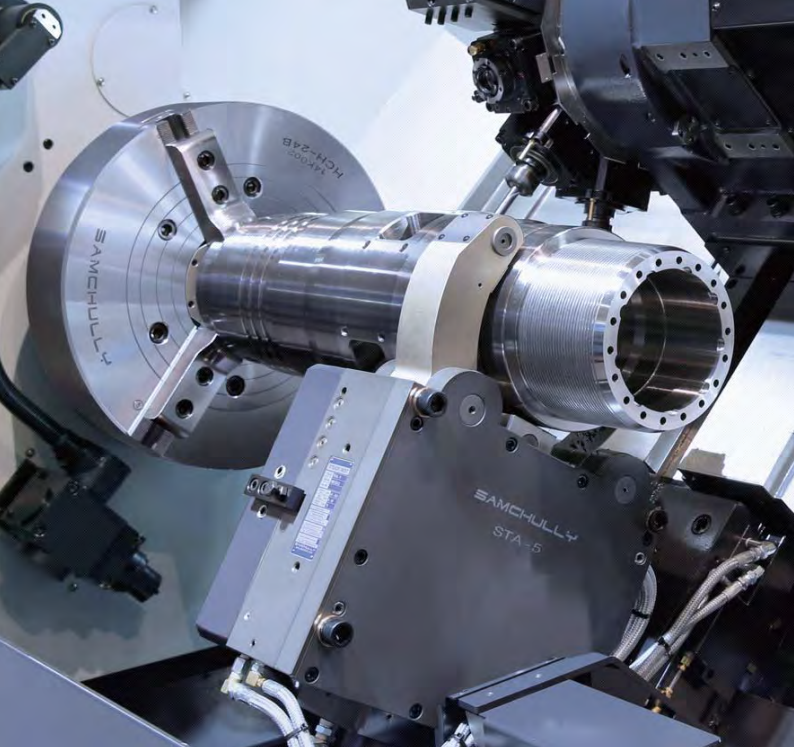

Global Work-holding Brand

www.samchully.com

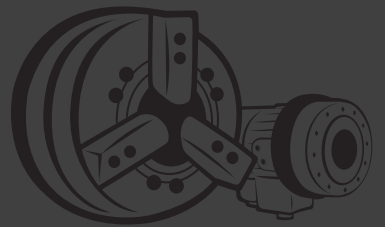



Samchully Machinery Co., Ltd.

Offers 30 years of experience in providing a wide range of premium quality work-holding products such as application, hydraulic, and manual chucks, milling vises, magnet chuck and rotary tables.

In keeping with our tradition of providing quality products, we perennially hold ISO:9001 and TUV certifications. Samchully Machinery Co., Ltd. also received Single Part Per Million certification [Single PPM] in 2007. The Single PPM quality assurance program is specifically adapted to North-East Asian manufacturing which relies heavily on outsourcings to leverage economies of scale. The Single PPM program emphasizes close collaboration with employees and vendors to reduce incoming component defects to a single digit (less than 10) for every million parts received.

Samchully is one of the first certified organizations in South Korea.









We proudly supply some of the world's leading machine tool makers, including Doosan (Daewoo), Hyundai-Wia (Kia) and Haas Automation, and provide after-market sales support through an extensive global network of distributors.

At Samchully, we are committed to you, our customer. We pride ourselves in providing the best value product in the world by combining premium quality, affordable pricing, and reliable service. We believe that you deserve better workholding options— you deserve Samchully.



SAMCHULLY

Contents

	SPECIAL CHUCK	4
	POWER CHUCK	38
	ROTARY CYLINDER	102
	MANUAL CHUCK	130
	STEADY RESTS	148
	NC ROTARY TABLE	154
	WISE	220
	MAGNET CHUCK	242
	ACCESSORIES	254



SPECIAL CHUCK

Samchully provides superior solutions to complicated workholding applications. High production and/or work pieces that have complex features difficult to hold with standard chucks require custom workholding. With over 40 years of manufacturing experience, Samchully has developed workholding solutions to many of the worlds largest manufactures. Samchully has the ability to design, build and test the complete solution to ensure a consistent, high quality product.



PBL

Universal Ball-Lock
Power Chuck

06 P



COR

Outside-Collet
Chuck

18 P



PHD

Outside Pull-Down
Chuck

28 P



PIL

Inside Pin Arbor
Chuck

08 P



FD

Finger Chuck

19 P



PHDN

Inside Pull-Down
Chuck

30 P



POL

Outside Pin Arbor
Chuck

09 P



DP

Diaphragm Chuck

20 P



RS

Retractable-Jaw
Shaft Chuck

32 P



DDL

Outside Draw-
Down Chuck

10 P



GDP

Gear Chuck

21 P



CSF

Compensating
Chuck

34 P



DDO

Inside Draw-Down
Chuck

12 P



BDG

Bevel-Gear Chuck

22 P



FWC

Aluminum Wheel
Chuck

36 P



DDT

Outside 2-Jaw
Draw-Down Chuck

14 P



IAHT

Auto-Indexing
Chuck

23 P



CDO

Outside-Collet
Chuck

16 P



IAH

Auto-Indexing
Chuck

24 P



CDI

Inside-Collet
Chuck

17 P



IAN

Auto-Indexing
Chuck

26 P

PBL Universal Ball-Lock Power Chuck



Application / Benefits

Compensating feature provides proper clamping for rough castings or forgings
Ability to clamp OD and ID

Technical features

Grips on tapers up to 10°
Jaws pivot up to 5° to grip on uneven surfaces

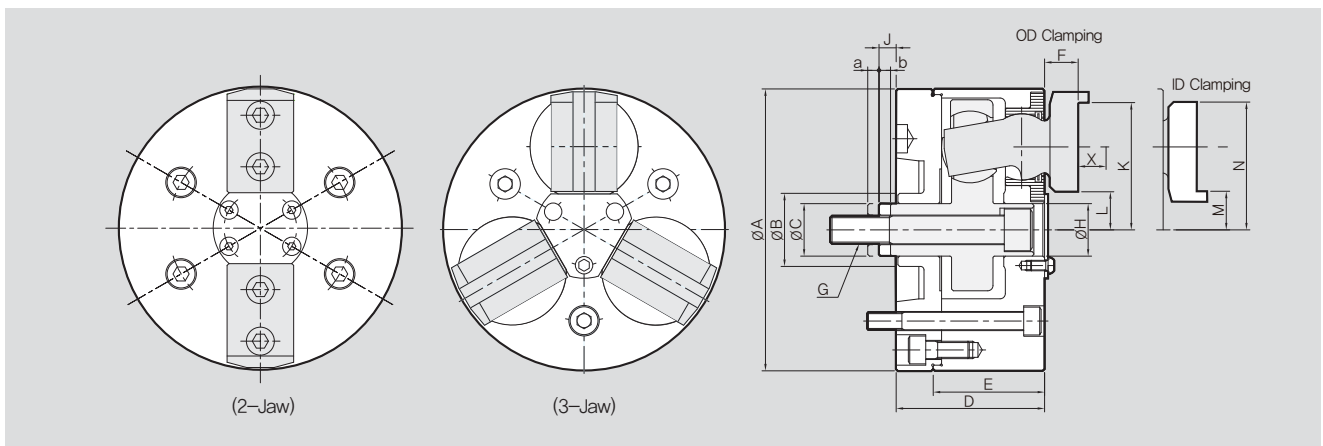

DIMENSIONS

	PBL-06	PBL-08	PBL-10	PBL-12	PBL-15	PBL-18	PBL-21	PBL-24
ØA	162	200	254	300	381	457	533	610
ØB min.	40	45	58	58	83	120.7	120.7	-
ØC	30.16	31.75	41.27	41.27	57.16	88.9	88.9	80
D	85.2	100	118	118	131	131	131	131
E	59.2	70	86.6	86.6	96.1	96.1	96.1	100.9
F	19.3	23.3	29.1	29.1	32.4	32.4	32.4	32.4
G	M16	M16	M18	M18	M24	M30	M30	M30
ØH	30.170	31.760	41.285	41.285	57.160	88.900	88.900	88.900
J	10.6	10.4	13.5	13.5	24.7	31.7	31.7	31.7
a	5.1	8	8	8	10.3	10.3	10.3	10.3
b	6.2	6.4	9.5	9.5	12	12	12	12
K	73.15	88.95	112.7	133.27	171.45	209.55	247.65	285.8
L	20.3	25.3	30.2	50.87	65.8	103.9	142	180.2
M	22.1	25.35	30.3	50.77	69.8	107.9	146	184.2
N	75	89	112.8	133.37	175.46	213.6	252	289.81
X	24.9	29.4	36.5	36.5	41.9	41.9	41.9	41.9

SPECIFICATIONS

	PBL-06	PBL-08	PBL-10	PBL-12	PBL-15	PBL-18	PBL-21	PBL-24	
Max. Clamping Force [kgf]	6600	8700	10800	10800	16500	16500	16500	16500	
Max. Drawbar Pull [kgf]	2200	2900	3600	3600	5500	5500	5500	5500	
Jaw Stroke Dia. [mm]	7.9	9.5	12.7	12.7	15.8	15.8	15.8	15.8	
Plunger Stroke [mm]	11.3	14.3	17.5	17.5	22.3	22.3	22.3	22.3	
Clamping Range [mm]	Outside Dia.	12.7~120	16~152	50~203	63~241	76~317	89~394	162~470	180~520
	Inside Dia.	70~152	76~203	85~235	127~305	165~381	241~457	317~533	350~600
Max. Speed [r.p.m.]	4000	3500	2500	2000	1800	1500	1000	1000	
Weight [kg]	18.0	27.0	45.0	67.5	84.5	120.0	180.0	290	
GD2 [kgf·m ²]	0.15	0.48	1.23	2.42	8.49	15.17	25.00	25	

Centralizing

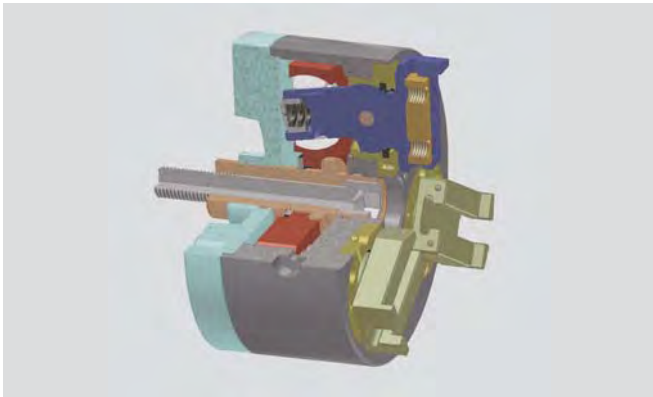

Compensating

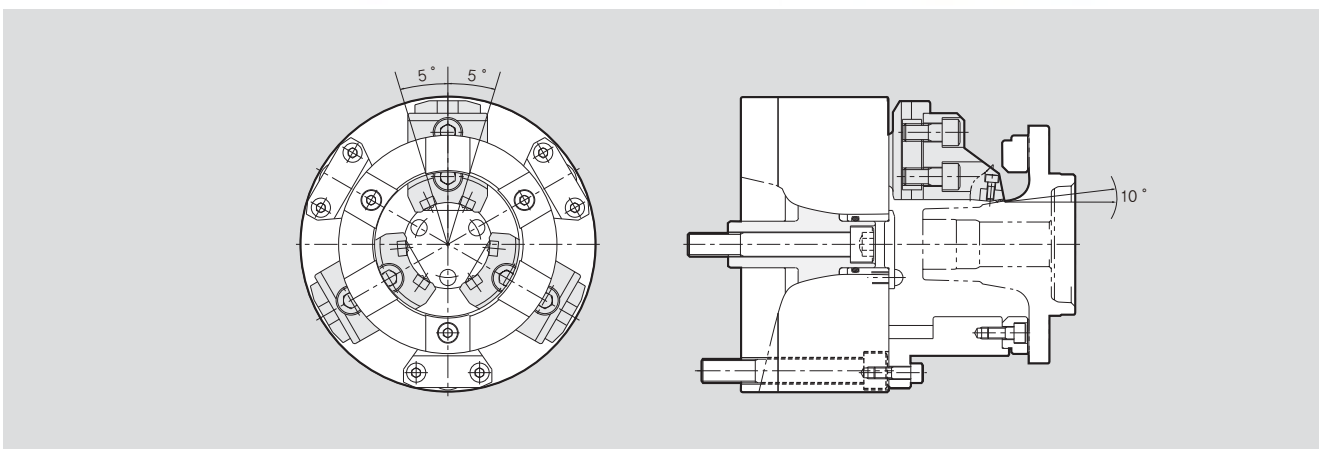
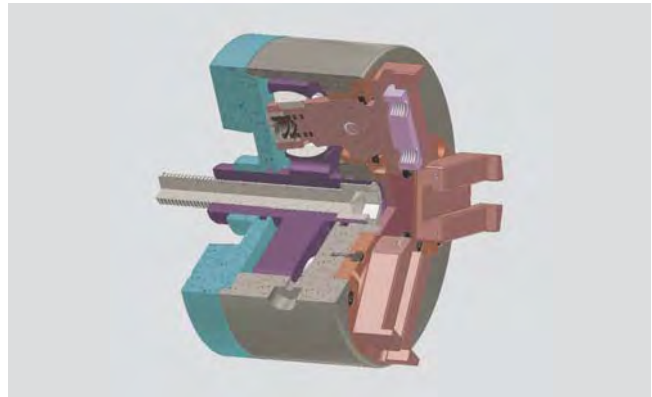

PBL Components

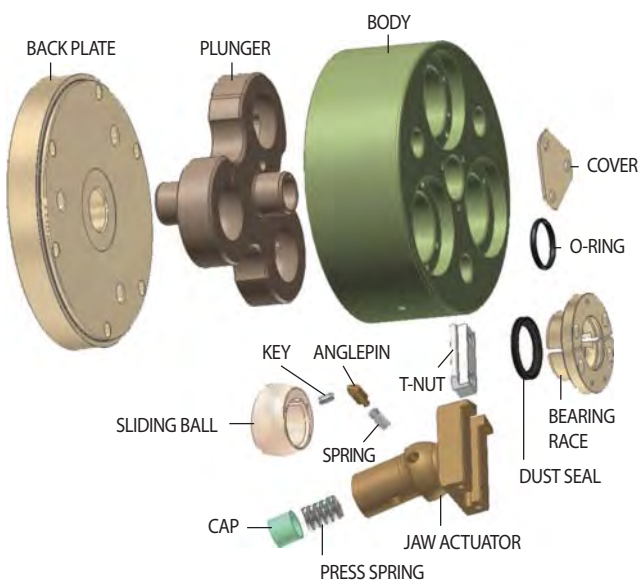

Inserts

Angle Lot Style			
PC127-10SC	PC127-4SC	PC130-4SC	
PC132-4SC	PC145-5SC		
PC127-4SC-S	PC130-2SC-S		
Round Style			
PC070-12SC	PC070-4SC		

PIL Inside Pin Arbor Chuck



Application / Benefits

Ideal for second operation I.D. gripping

Technical features

Active pull-down for high precision

Counter centrifugal gripping reduces distortion

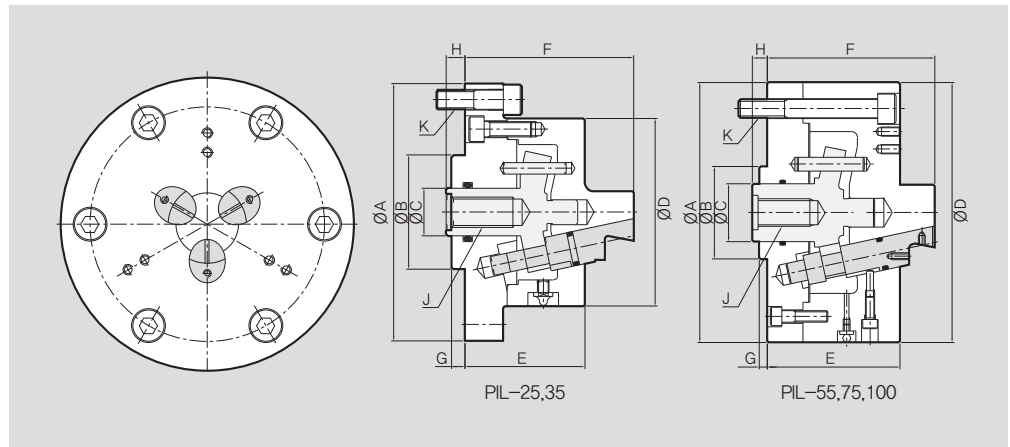
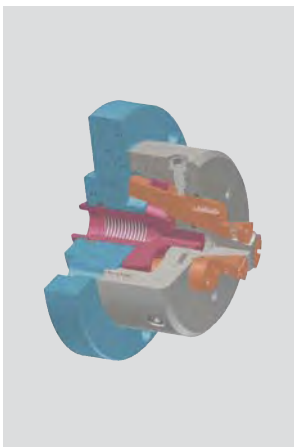

DIMENSIONS

	PIL-25	PIL-35	PIL-55	PIL-75	PIL-100
ØA	135	135	190	225	270
ØB(h7)	60	60	80	80	120
ØC	20	25	32	50	50
ØD	85	100	190	225	270
E	60	63	93	115	130
F	80	88.5	120	145	170
G	7	7	7	7	7
Hmax.	12	12	18	18	23
Hmin.	8	8	8	8	13
J	M12	M16	M16	M24	M24
K	3-M10 PCD118	3-M10 PCD118	3-M16 PCD150	6-M16 PCD180	6-M16 PCD180

SPECIFICATIONS

	PIL-25	PIL-35	PIL-55	PIL-75	PIL-100	
Max. Clamping Force [kgf]	2250	3380	5640	7150	7150	
Max. Drawbar Pull [kgf]	1200	1800	3000	3800	3800	
Jaw Stroke Dia. [mm]	1.7	1.7	4.2	4.2	4.2	
Plunger Stroke [mm]	4	4	10	10	10	
Clamping Range [mm]	Pin Jaw	17~25	25~40	35~55	55~76	80~110
	Top Jaw	-	48~60	62~90	85~130	120~180
Max. Speed [r.p.m.]	5000	4500	3500	2500	2000	
Weight [kg]	3.5	4.3	18.4	35	55	
GD2 [kgf·m ²]	0.013	0.026	0.33	0.88	2.0	

POL Outside Pin Arbor Chuck



Application / Benefits

Ideal for second operation O.D. gripping on thin walled parts

Technical features

Active pull-down for high precision

Counter centrifugal gripping reduces distortion

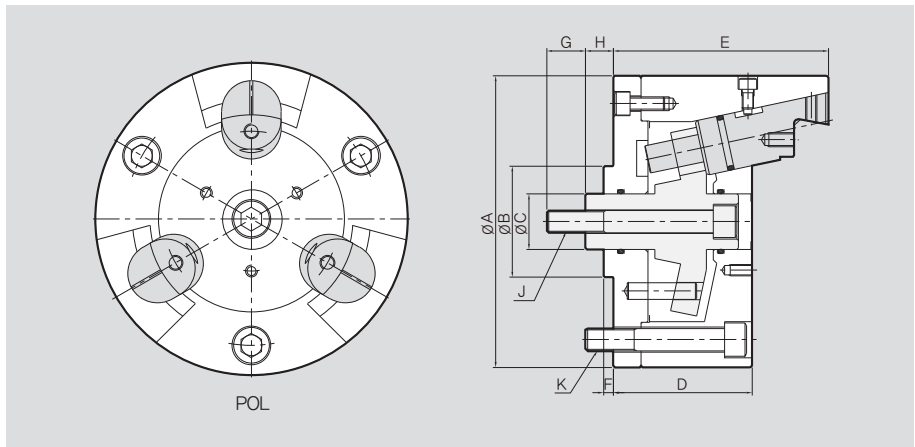
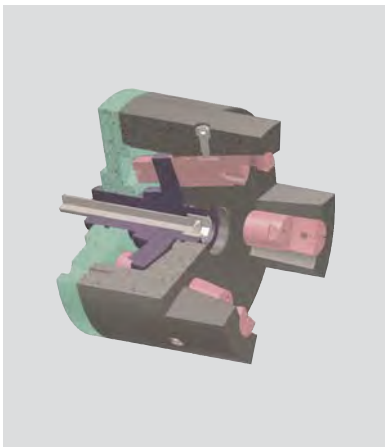

DIMENSIONS

	POL-80	POL-100	POL-140	POL-180	POL-230	POL-300
ΦA	130	162	210	250	320	400
ΦB(h7)	60	80	80	80	120	-
ΦC	24	30	40	45	50	60
ΦD	72	90	100	110	130	137
E	103	130	155	165	200	248
F	5	7	7	7	7	7
G	20	30	30	30	40	40
Hmax.	18	22.5	25	25	30	25
Hmin.	10	12.5	15	15	20	15
J	M12	M16	M16	M18	M20	M35
K	3-M8 PCD100	3-M12 PCD130	3-M16 PCD170	3-M16 PCD210	6-M16 PCD270	M24

SPECIFICATIONS

	POL-80	POL-100	POL-140	POL-180	POL-230	POL-300	
Max. Clamping Force [kgf]	2250	3760	4700	5640	7520	7520	
Max. Drawbar Pull [kgf]	1200	2000	2500	3000	4000	4000	
Jaw Stroke Dia. [mm]	3.4	4.2	4.2	4.2	4.2	4.2	
Plunger Stroke [mm]	8	10	10	10	10	10	
Clamping Range [mm]	Pin Jaw	65~80	86~100	120~140	150~180	-	-
	Top Jaw	15~60	20~80	60~110	100~145	120~200	150~270
Max. Speed [r.p.m.]	5000	4500	3000	2000	2000	2000	
Weight [kg]	8	16	27	46	70	165	
GD2 [kgf·m ²]	0.067	0.2	0.54	1.43	3.5	5.6	

DDL Outside Draw-Down Chuck



Application / Benefits

Workpiece pulled down to location for superior accuracy

Technical features

Very accurate for parallel and perpendicular surfaces

Sealed to prevent chips and coolant from entering the chuck body

SPECIFICATIONS

	DDL-04	DDL-05	DDL-06	DDL-08	DDL-10	DDL-12	DDL-15	DDL-20	
Max. Clamping Force [kgf]	1350	2000	2500	4500	6000	7500	9000	23800	
Max. Drawbar Pull [kgf]	800	1000	1500	2500	3500	4500	5500	9100	
Jaw Stroke Dia. [mm]	5	5.0	7.2	7.2	10.8	10.8	14.5	18	
Plunger Stroke [mm]	7	7	10	10	15	15	20	28	
Clamping Range [mm]	Pin Jaw	10~55	15~65	35~85	40~200	50~250	50~300	60~380	80~450
	Top Jaw	10~50	15~60	35~80	40~150	50~200	50~250	60~320	80~400
Max. Speed [r.p.m.]	5500	3500	3500	3000	2500	2000	1500	1700	
Weight [kg]	4.5	7.3	14	27	46	68	110	230	
GD2 [kgf·m ²]	0.05	0.07	0.18	0.66	1.50	3.20	9.00	12	

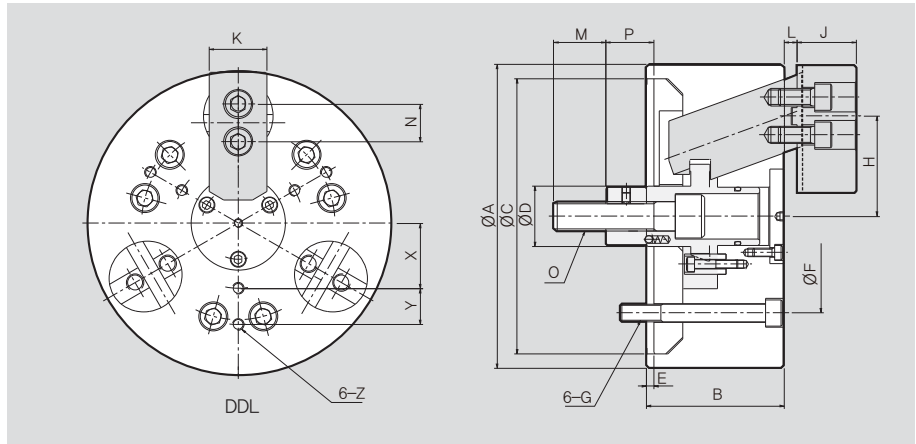
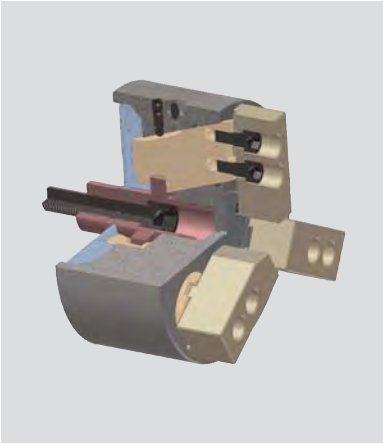

DIMENSIONS

	DDL-04	DDL-05	DDL-06	DDL-08	DDL-10	DDL-12	DDL-15	DDL-20
ØA	98	130	165	210	254	304	381	500
B	60	70	85	95	110	125	140	150
ØC(h7)	60	80	140	190	230	230	300	420
ØD	25	28	34	40	50	54	60	95
E	5	5	5	5	5	5	8	9
ØF	80	100	104.8	133.4	171.4	171.4	230	360
G	3-M8	3-M8	M10	M12	M16	M16	M20	-
Hmax.	38.25	44	58	71	85	102	133.6	180.5
Hmin.	33.25	41.5	54.4	67.4	79.6	96.6	126.4	171.4
J	19.5	24.5	31	41	49	51	60	71
K	25	30	35	40	50	60	70	80
Lmax.	10.5	10.5	14	14	19	19	26	32
Lmin.	3.5	3.5	4	4	4	4	6	7
M	20	25	36	36	46	50	47	49
N	-	-	-	26	32	36	40	44
O	M10	M12	M16	M20	M24	M27	M30	-
Pmax.	14	24	33	38	47	47	71	72
Pmin.	7	17	23	28	32	32	51	47
X	25	30	35	45	55	70	95	150
Y	-	-	20	25	30	35	45	50
Z	3-M6	M6	M6	M8	M8	M10	M12	M16

DDO Inside Draw-Down Chuck



Application / Benefits

Workpiece pulled down to location for superior accuracy

Technical features

Very accurate for parallel and perpendicular surfaces

Sealed to prevent chips and coolant from entering the chuck body

SPECIFICATIONS

	DDO-06	DDO-08	DDO-10	DDO-12	DDO-15	
Max. Clamping Force [kgf]	2500	4500	6000	7500	9000	
Max. Drawbar Pull [kgf]	1500	2500	3500	4500	5500	
Jaw Stroke Dia. [mm]	5.8	7.2	10.8	10.8	14.5	
Clamping Range [mm]	Standard	35~140	40~180	50~220	60~270	250~340
	Top Jaw	70~140	90~180	100~220	110~220	200~340
Max. Speed [r.p.m.]	5000	4500	4000	3500	1500	
Weight [kg]	13	26	44	68	110	
GD2 [kgf·m ²]	0.18	0.66	1.50	2.90	6.5	

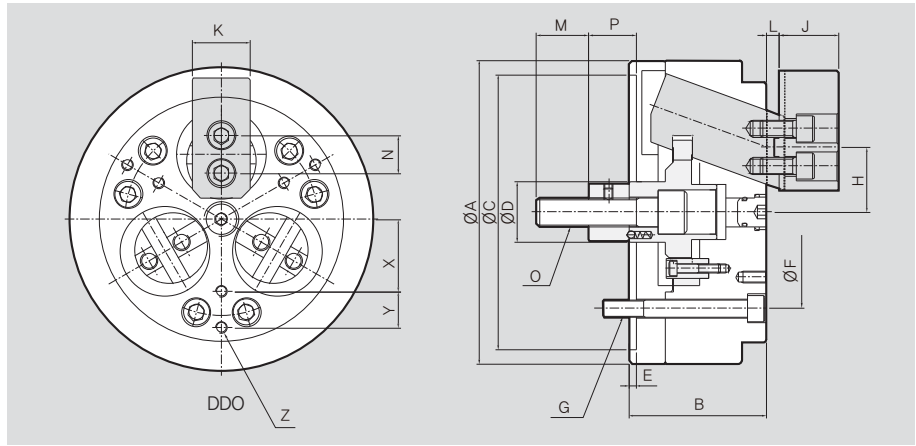
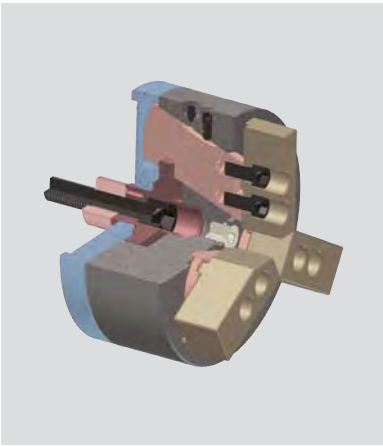

DIMENSIONS

	DDO-06	DDO-08	DDO-10	DDO-12	DDO-15
ØA	165	210	254	304	381
B	80	95	110	125	140
ØC(h7)	140	190	230	230	300
ØD	35	42	52	80	60
E	5	5	5	5	8
ØF	104.8	133.4	171.4	171.4	230
G	M10	M12	M16	M16	M20
Hmax.	37.9	46.6	57.9	65.4	93.6
Hmin.	35	43	52.5	60	86.4
J	30	41	46	51	60
K	35	40	50	60	70
Lmax.	12	14	19	19	26
Lmin.	4	4	4	4	6
M	36	36	46	50	55
N	-	26	32	36	40
O	M16	M20	M24	M27	M30
Pmax.	31	38	47	47	63
Pmin.	23	28	32	32	43
X	40	50	60	70	95
Y	20	25	30	40	45
Z	M6	M8	M8	M10	M12

DDT Outside 2-Jaw Draw-Down Chuck

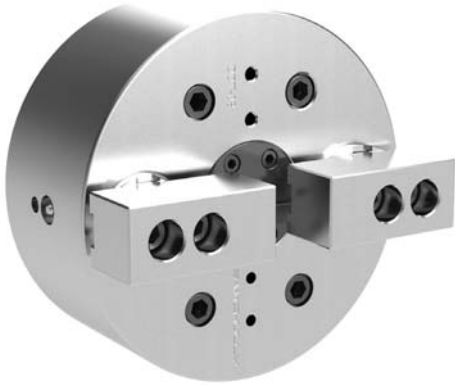

Application / Benefits

Workpiece pulled down to location for superior accuracy

Technical features

Ideal for machining square, rectangular and irregularly-shaped components
Very accurate for parallel and perpendicular surfaces

SPECIFICATIONS

	DDT-06	DDT-08	DDT-10
Max. Clamping Force [kgf]	1600	2800	4000
Max. Drawbar Pull [kgf]	1000	1700	2500
Jaw Stroke Dia. [mm]	7.2	7.2	10.2
Plunger Stroke [mm]	11.0	11.0	16.0
Clamping Range [mm]	Standard	40~200	50~250
	Top Jaw	35~80	40~150
Max. Speed [r.p.m.]	2500	2200	1800
Weight [kg]	14	26	42
GD2 [kgf·m ²]	0.19	0.57	1.50

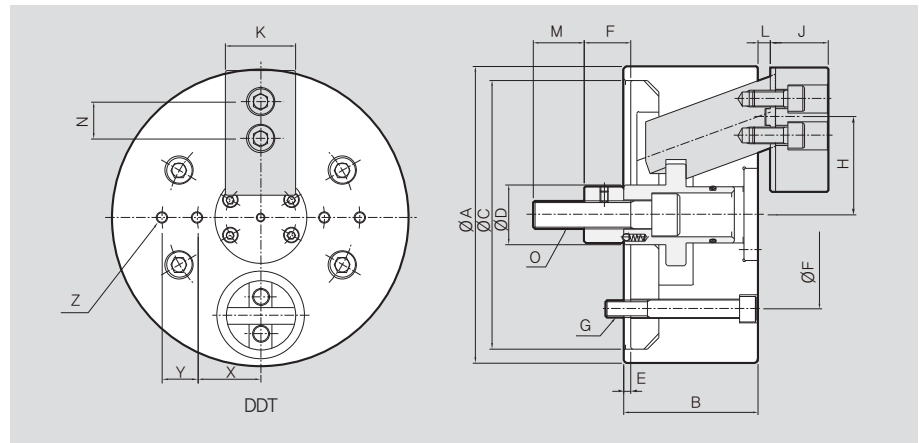
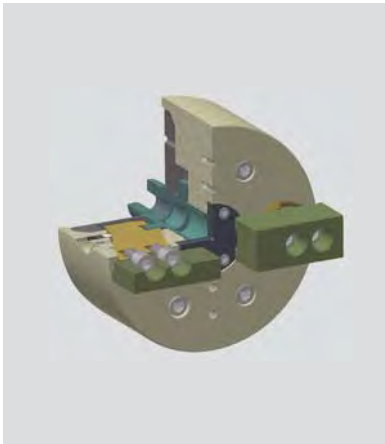

DIMENSIONS

	DDT-06	DDT-08	DDT-10
ØA	160	210	254
B	85	95	110
ØC(h7)	140	190	230
ØD	35	42	52
E	5	5	5
ØF	104.8	133.4	171.4
G	M10	M12	M16
Hmax.	58	71	85
Hmin.	54.4	67.5	79.9
J	31	41	46
K	35	40	50
Lmax.	18	15	23
Lmin.	8	8	9
M	36	38	46
N	-	26	32
O	M16	M20	M24
Pmax.	34	39	48
Pmin.	23	28	32
X	35	45	55
Y	20	25	30
Z	M6	M8	M8

CDO Outside-Collet Chuck



Application / Benefits

OD clamping of entire workpiece eliminates distortion
Pull down feature to locator provides superior accuracy

Technical features

Interchangeable top jaws grip the workpiece O.D.
Capable of air sensing and/or air/coolant porting for chip removal

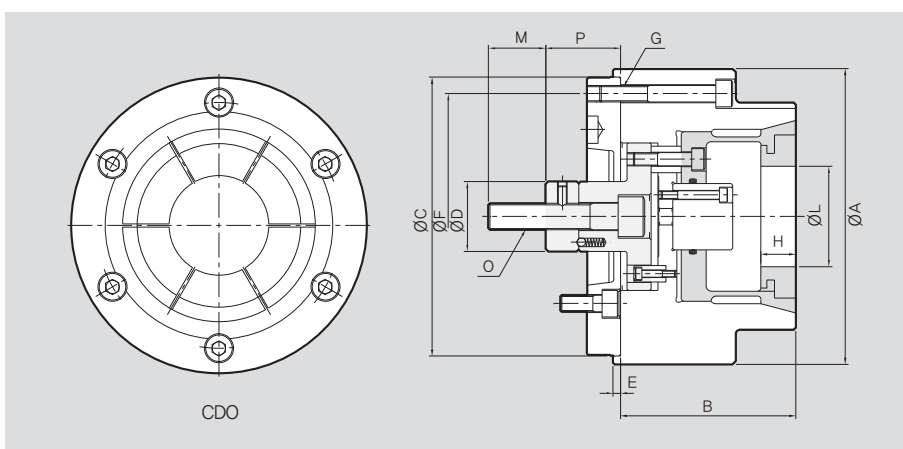
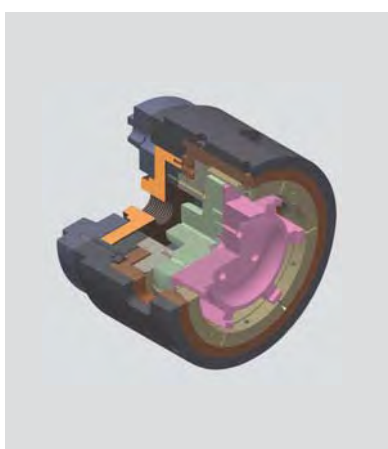

DIMENSIONS

	CDO-06	CDO-08	CDO-10	CDO-12
ØA	165	210	250	300
B	115	125	145	170
ØC(h7)	150	200	230	230
ØD	35	42	52	52
E	5	5	5	5
ØF	130	180	210	270
G	M12	M12	M16	M16
H	30	35	45	50
ØLmax.	50	90	130	180
ØLmin.	15	80	80	100
M	36	36	46	50
O	M16	M20	M24	M24
Pmax.	26	32	35	36
Pmin.	23	29	32	32

SPECIFICATIONS

	CDO-06	CDO-08	CDO-10	CDO-12
Max. Clamping Force [kgf]	2800	4600	6500	7500
Max. Drawbar Pull [kgf]	1500	2500	3500	4000
Jaw Stroke Dia. [mm]	1.6	1.6	1.6	2.0
Plunger Stroke [mm]	3	3	3	4
Clamping Range [mm]	Max	80	130	180
	Min	15	40	100
Max. Speed [r.p.m.]	4500	4000	3300	2500
Weight [kg]	11	23	49	67
GD2 [kgf·m ²]	0.11	0.44	1.76	3.10

CDI Inside-Collet Chuck



Application / Benefits

High accuracy, Good torque transmission
Even clamping pressure for no deformation
Custom made mandrels

Technical features

Pull down feature for better accuracy
Vulcanized rubber to protect mandrels from chips
Easily ported for air sensing or air/coolant for chip removal

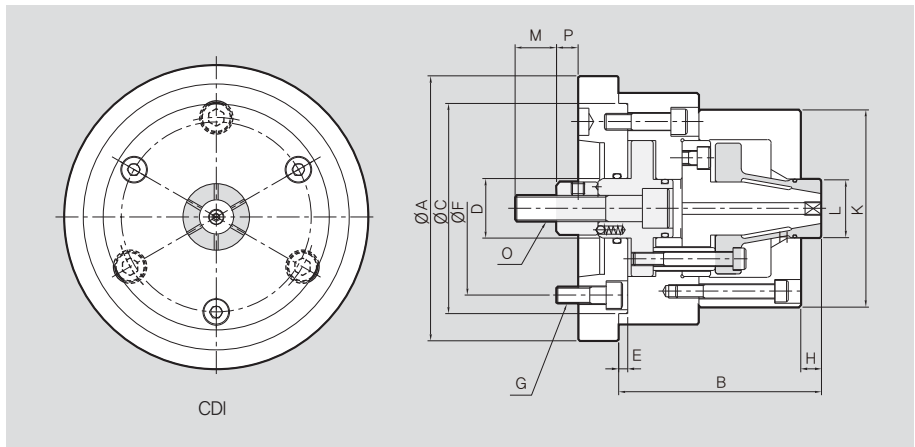
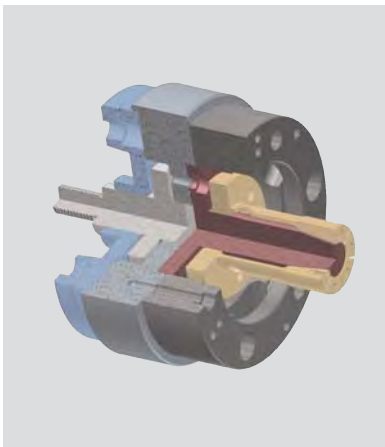

DIMENSIONS

	CDI-06	CDI-08	CDI-10	CDI-12
ΦA	165	200	250	300
B	115	135	180	220
ΦC(h7)	150	170	230	230
ΦD	35	42	52	52
E	6	6	6	6
ΦF	104.8	133.4	171.4	171.4
G	M10	M12	M16	M16
H	15	20	35	40
ΦK	L+25	L+35	L+40	L+50
ΦLmax.	15	90	130	180
ΦLmin.	40	40	90	130
M	40	45	55	55
O	M16	M20	M24	M24
Pmax.	26	33	36	37
Pmin.	23	29	32	32

SPECIFICATIONS

	CDI-06	CDI-08	CDI-10	CDI-12
Max. Clamping Force [kgf]	4000	7000	12000	15000
Max. Drawbar Pull [kgf]	1500	2500	4000	4800
Jaw Stroke Dia. [mm]	0.8	1.0	1.0	1.4
Plunger Stroke [mm]	3	4	4	5
Clamping Range [mm]	Max	90	130	180
	Min	15	40	90
Max. Speed [r.p.m.]	4500	4000	3300	2500
Weight [kg]	7	14	34	55
GD2 [kgf·m ²]	0.06	0.19	0.71	2

COR Outside-Collet Chuck



Application / Benefits

Quick change OD clamping collet chuck
No centrifugal losses for consistent clamp forces

Technical features

Vulcanized rubber - steel segmented collet
Round, square and hexagonal collets available

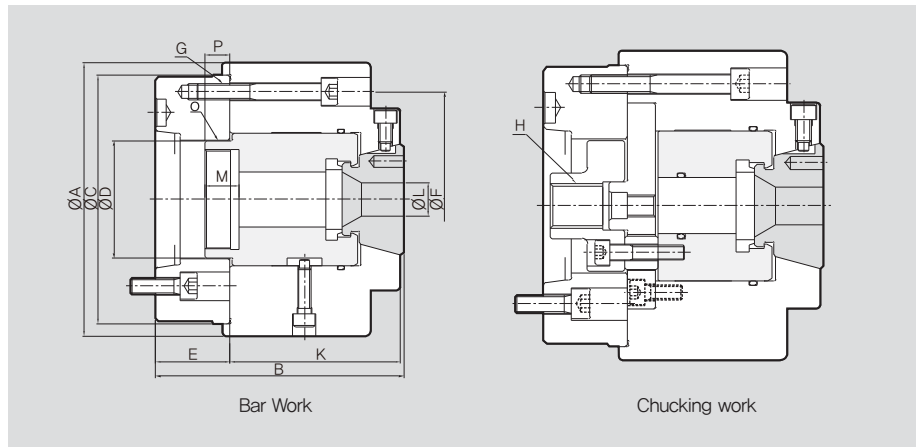
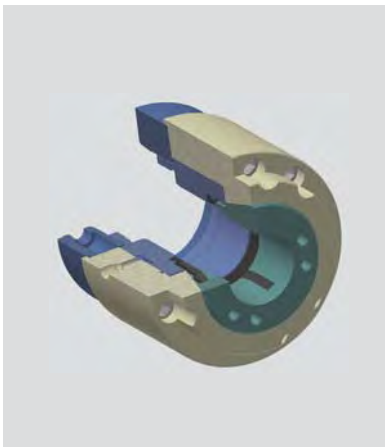

DIMENSIONS

	COR-32	COR-50	COR-65	COR-90
ΦA	165	165	180	210
B	150	150	170	190
$\Phi C(h7)$	150	150	170	170
ΦD	71	87	103	103
E	45	45	49	55
ΦF	130	130	150	150
G	M10	M10	M12	M12
H	M24	M24	M30	M30
K	103	103	119	133
$\Phi L_{max.}$	32	50	65	90
$\Phi L_{min.}$	5	12	16	30
M	20.5	27.5	25	25
O	M60x2.0	M74x1.5	M90x2.0	M90x2.0
Pmax.	16.5	23	25.5	28.5
Pmin.	13.5	20	22.5	22.5

SPECIFICATIONS

	COR-32	COR-50	COR-65	COR-90
Max. Clamping Force [kgf]	6400	8200	9200	13300
Max. Drawbar Pull [kgf]	3200	4100	4600	6500
Collect Expansion [mm]	1.0	1.0	1.0	2.0
Plunger Stroke [mm]	3	3	3	6
Chucking Dia. [mm]	Bar Work	12~50	16~65	30~90
	Chuck Work	7~32	12~50	16~65
Max. Speed [r.p.m.]	4500	4500	4000	3500
Weight [kg]	25	25	32	38

FD Finger Chuck



Application / Benefits

Ideal for thin walled parts to eliminate distortion by clamping onto the face

Technical features

Floating clamping fingers adjust to workpiece shape and will pull down to a locator
Available in 2-jaw, 3-jaw, and 4-jaw models

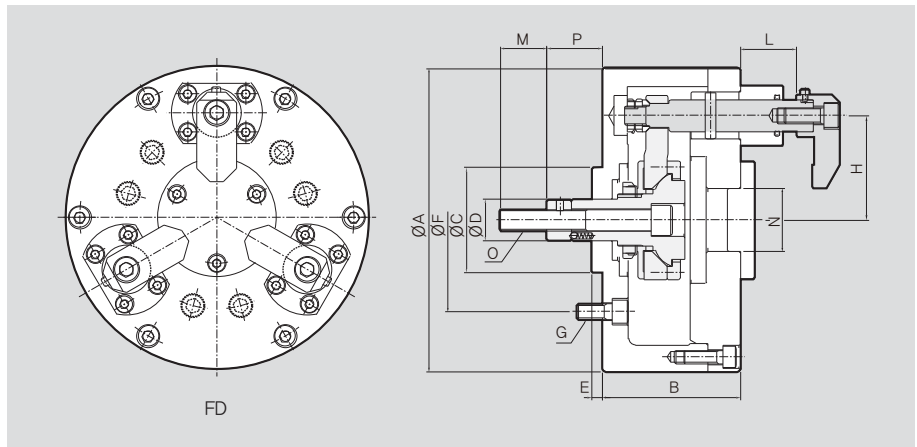
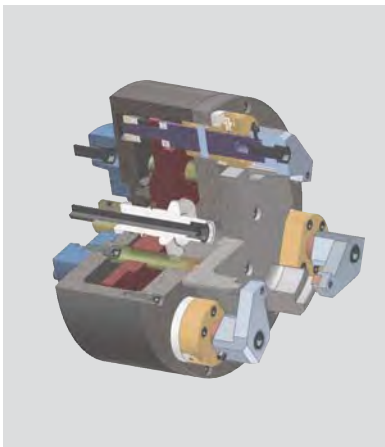

DIMENSIONS

	FD-06	FD-08	FD-10	FD-12	FD-15	FD-18
ØA	165	210	254	304	381	457
B	75	85	95	110	125	140
ØC(h7)	60	80	120	120	150	150
ØD	35	42	52	52	55	55
E	7	7	7	7	7	7
ØF	104.8	133.4	171.4	171.4	230	230
G	M10	M12	M16	M16	M20	M20
H	55	75	95	120	155	192
ØLmax.	54	59	72	72	84	84
ØLmin.	30	35	40	45	50	50
M	36	36	46	46	50	50
ØN	40	45	55	55	60	60
O	M16	M20	M24	M24	M27	M27
Pmax.	44	50	60	60	75	75
Pmin.	30	35	40	40	50	50

SPECIFICATIONS

	FD-06	FD-08	FD-10	FD-12	FD-15	FD-18
Max. Clamping Force [kgf]	1400	2100	2800	2800	3600	3600
Max. Drawbar Pull [kgf]	1800	2700	3600	3600	4500	4500
Jaw Stroke Dia. [mm]	2	2	2	2	2	2
Plunger Stroke [mm]	14	15	20	20	20	25
Clamping Range [mm]	Max	75	110	145	260	330
	Min	30	50	60	110	215
Max. Speed [r.p.m.]	3500	2800	2400	2100	1800	1500
Weight [kg]	9	18	30	41	73	102
GD2 [kgf·m ²]	0.12	0.41	1.05	2.17	5.65	11.6

DP Diaphragm Chuck



Application / Benefits

Ideal for cylindrical grinding, turning and hard turning that require high concentricity and roundness.
Thin walled or fragile parts that are easily distorted.
Can hold accuracies up to 2 μ

Technical features

Minimal maintenance due to sealed body
Can be configured to be self contained or by drawbar

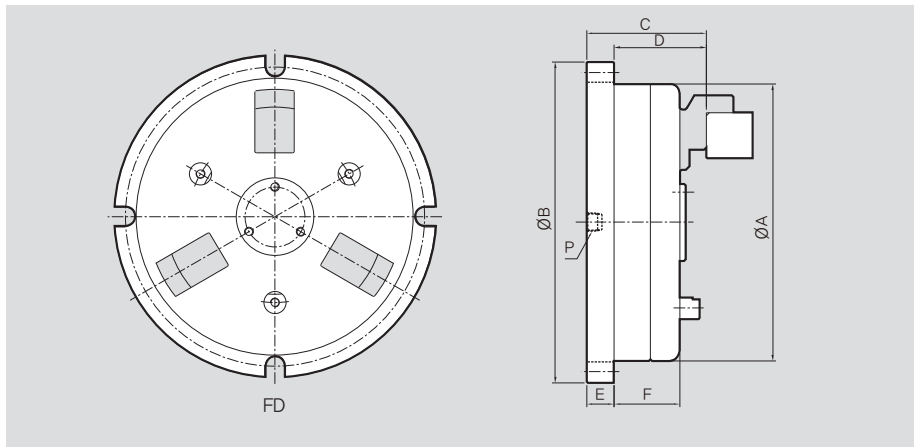

DIMENSIONS

	DP-06	DP-08	DP-10	DP-13	DP-17
ØA	171.4	212.9	251	327.2	428.9
ØB	208	246	284	360	476
C	92	96.8	96.8	108	109.5
D	72.9	77.7	77.7	88.9	90.4
E	19.1	19.1	19.1	19.1	19.1
F	65	70	85	85	85
P	1/4	1/4	1/4	1/4	1/4

SPECIFICATIONS

	DP-06	DP-08	DP-10	DP-13	DP-17
Max. Clamping Force [kgf]	450	720	1150	2000	3600
No. of Jaw	3 (6Jaw)	3 (6Jaw)	3 (6Jaw)	3 (6Jaw)	3 (6Jaw)
Jaw Stroke [kgf]	0.23	0.25	0.25	0.35	0.40
Grip Dia. [mm]	44~107	76~143	114~181	150~248	203~349
Max. Speed [r.p.m.]	4500	4000	3500	3000	2000
Pressure [kgf/cm ²]	4.5	4.5	4.5	4.5	4.5
Weight [kg]	11	20	26.5	43	89

GDP Gear Chuck



Application / Benefits

Diaphragm chuck with a pin cage to clamp onto gears by their pitch diameter.

Technical features

Diaphragm chuck for hard turning/ grinding gears
Jaws can be easily changed

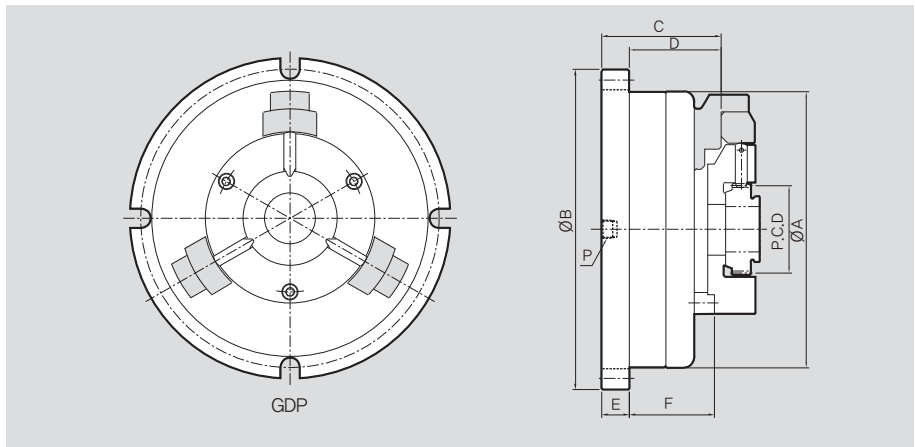
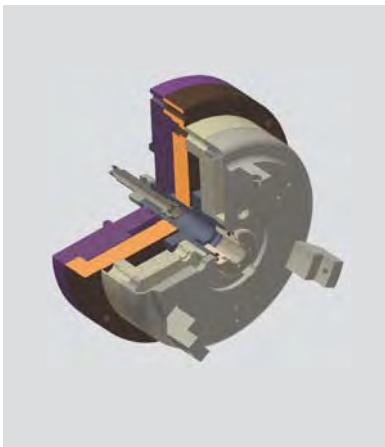

DIMENSIONS

	GDP-08	GDP-10	GDP-13	GDP-17
ØA	212.9	251	327.2	428.9
ØB	246	284	360	476
C	96.8	96.8	108	109.5
D	77.7	77.7	88.9	90.4
E	19.1	19.7	19.1	19.1
F	70	85	85	85
P	1/4	1/4	1/4	1/4
H	55	75	95	120
Lmax.	54	59	72	72
Lmin.	30	35	40	45
M	36	36	46	46
ØN	40	45	55	55
O	M16	M20	M24	M24
Pmax.	44	50	60	60
Pmin.	30	35	40	40

SPECIFICATIONS

	GDP-08	GDP-10	GDP-13	GDP-17
Max. Clamping Force [kgf]	720	1150	2000	3600
No. of Jaw	3	3	3	3
Jaw Stroke [kgf]	0.25	0.25	0.35	0.40
Grip Dia. [mm]	40~70	70~100	100~160	160~250
Max. Speed [r.p.m.]	4000	3500	3000	2000
Pressure [kgf/cm ²]	4.5	4.5	4.5	4.5
Weight [kg]	20	26.5	43	89

BDG Bevel-Gear Chuck



Application / Benefits

For ID machining of bevel gears.
Eliminates distortion by clamping onto face

Technical features

Finger chuck for high accuracy clamping of bevel gears
Floating action ensures equal clamping force on all 3 fingers
Available with hydraulic and pneumatic actuation

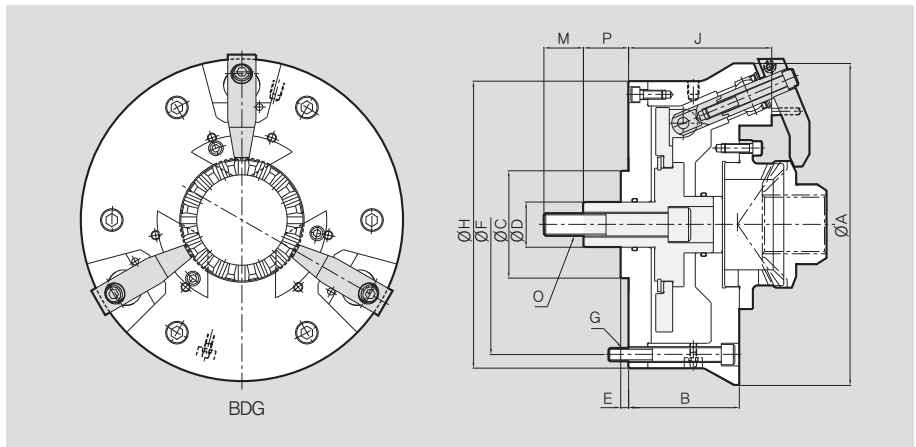
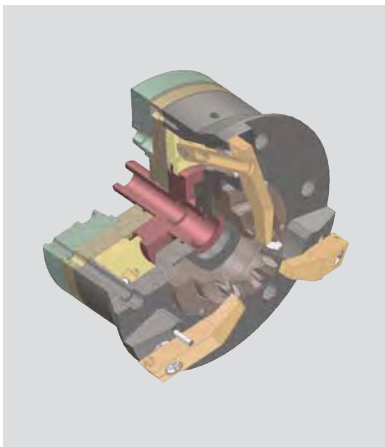

DIMENSIONS

	BDG-07	BDG-10
ΦA	215	285
B	98	98
ΦC(h7)	80	95
ΦD	30	40
E	7	7
ΦF	160	230
G	M12	M12
ΦH	185	254
J	126.5	126.5
M	27	35
O	M16	M20
Pmax.	45	45
Pmin.	30	30

SPECIFICATIONS

	BDG-07	BDG-10
Max. Drawbar Pull [kgf]	1500	1500
Plunger Stroke [mm]	15	15
Clamping Range [mm]	22.2 ~ 147.5	88.9 ~ 203.2
Max. Speed [r.p.m.]	2000	1500
Weight [kg]	30	45

IAHT Auto-Indexing Chuck



Application / Benefits

Machine multiple surfaces in a single clamping

Technical features

Accurate, durable indexing system

Index positions 6 x 60° or 3 x 120°, The check valve assures safe operation

Confirmation of index position via pressure sensors

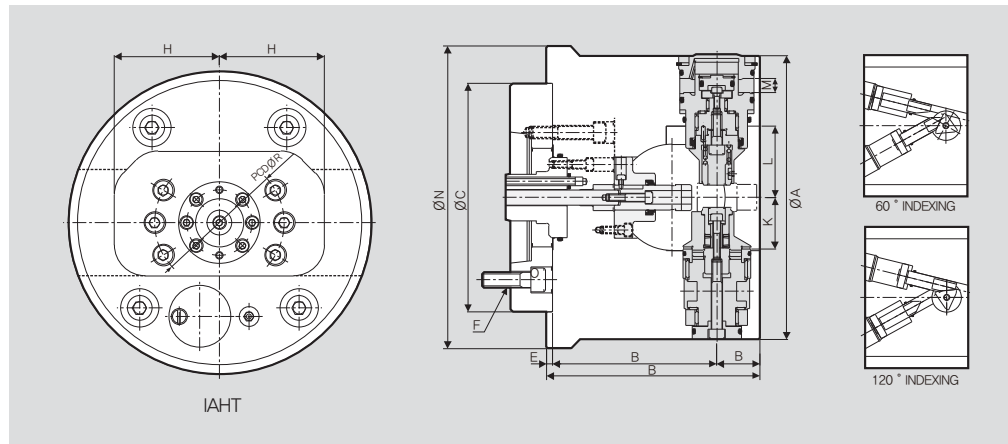
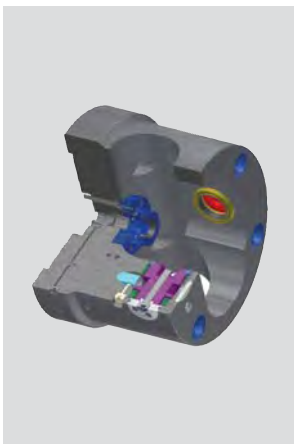

DIMENSIONS

	IAHT-230	IAHT-280	IAHT-300
ØA	230	280	300
B	158	193.5	200
ØC(h7)	130	170	170
D	123	143.5	143.5
E	15	11	11
F	M10	M16	M16
G	35	50	56.5
H	102	82.5	82.5
K	40	56	56
L	58	71	65
M	14.5	21	25
ØN	245	295	295
ØR	104.8	130	130

SPECIFICATIONS

	IAHT-230	IAHT-280	IAHT-300
Clamp Piston Area [cm ²]	1270	2170	3500
Main Spindle Bore [mm]	OVER 45	OVER 45	OVER 45
Max. Speed [r.p.m.]	2400	2000	1800
Weight [kg]	35	65	83
GD2 [kgf·m ²]	1.3	3.6	4.2

IAH Auto-Indexing Chuck



Application / Benefits

Machine multiple surfaces in a single clamping

Technical features

Accurate, durable indexing system

Index positions 4 x 90° or 8 x 45°, The check valve assures safe operation

Confirmation of index position via pressure sensors

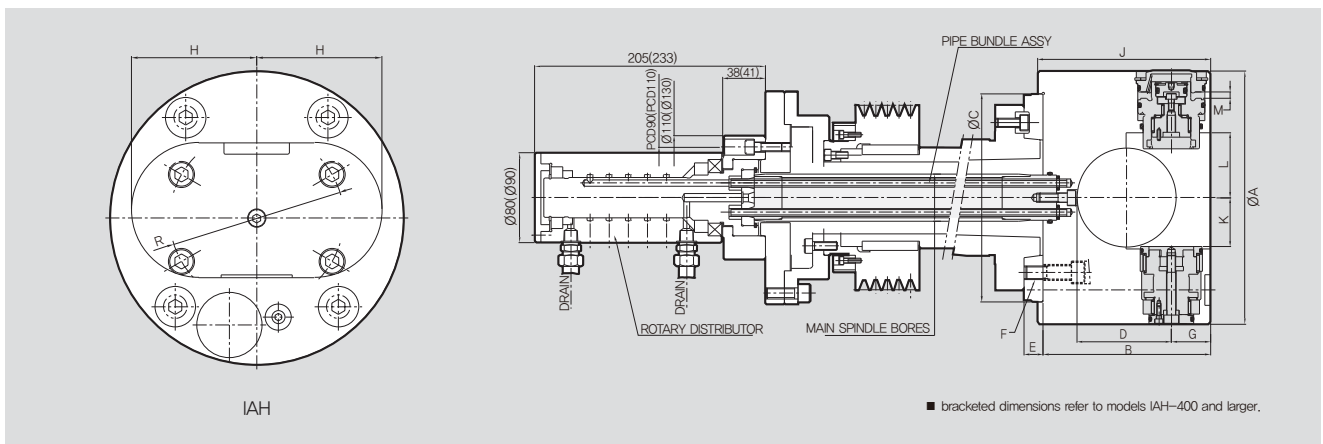

DIMENSIONS

	IAH-225	IAH-250	IAH-275	IAH-315	IAH-350	IAH-400	IAH-500	IAH-670
ΦA	225	250	280	315	350	400	500	670
B	149	185	208	227	235	253	301	465
ΦC(h7)	185	210	210	235	290	290	380	380
D	84	113	125	136	148	160	200	286
E	25	25	25	25	30	30	35	40
F	M12	M12	M16	M16	M20	M20	M20, M24	M24
G	35	40	48	50	50	60	68	90
H	95	106	125	136	145	165	205	275
J	154	190	213	232	240	259	308	470
K	46	46	57	70	84	100	133	176
L	58	55	67	85	102	114	157	214
M	11.5	20	20.5	22	23	30	35	40
ΦR	133.4	133.4	171.4	171.4	235	235	235	330.2

SPECIFICATIONS

	IAH-225	IAH-250	IAH-280	IAH-315	IAH-350	IAH-400	IAH-500	IAH-670
Max. Clamping Force [kgf]	1270	1730	2550	2550	2550	3530	4670	5890
Main Spindle Bore [mm]	OVER 45	OVER 45	OVER 45	OVER 45	OVER 55	OVER 55	OVER 55	OVER 55
Max. Speed [r.p.m.]	2800	2400	2000	1800	1800	1200	900	600
Weight [kg]	29	44	56	75	100	145	230	540
GD2 [kgf·m ²]	0.9	1.7	2.8	5.0	8.0	15.0	25.4	32.5
Max. Workpiece Size [mm]	60	65	80	100	135	170	220	300
Max. Workpiece Size [mm]	100	160	220	230	240	260	310	400

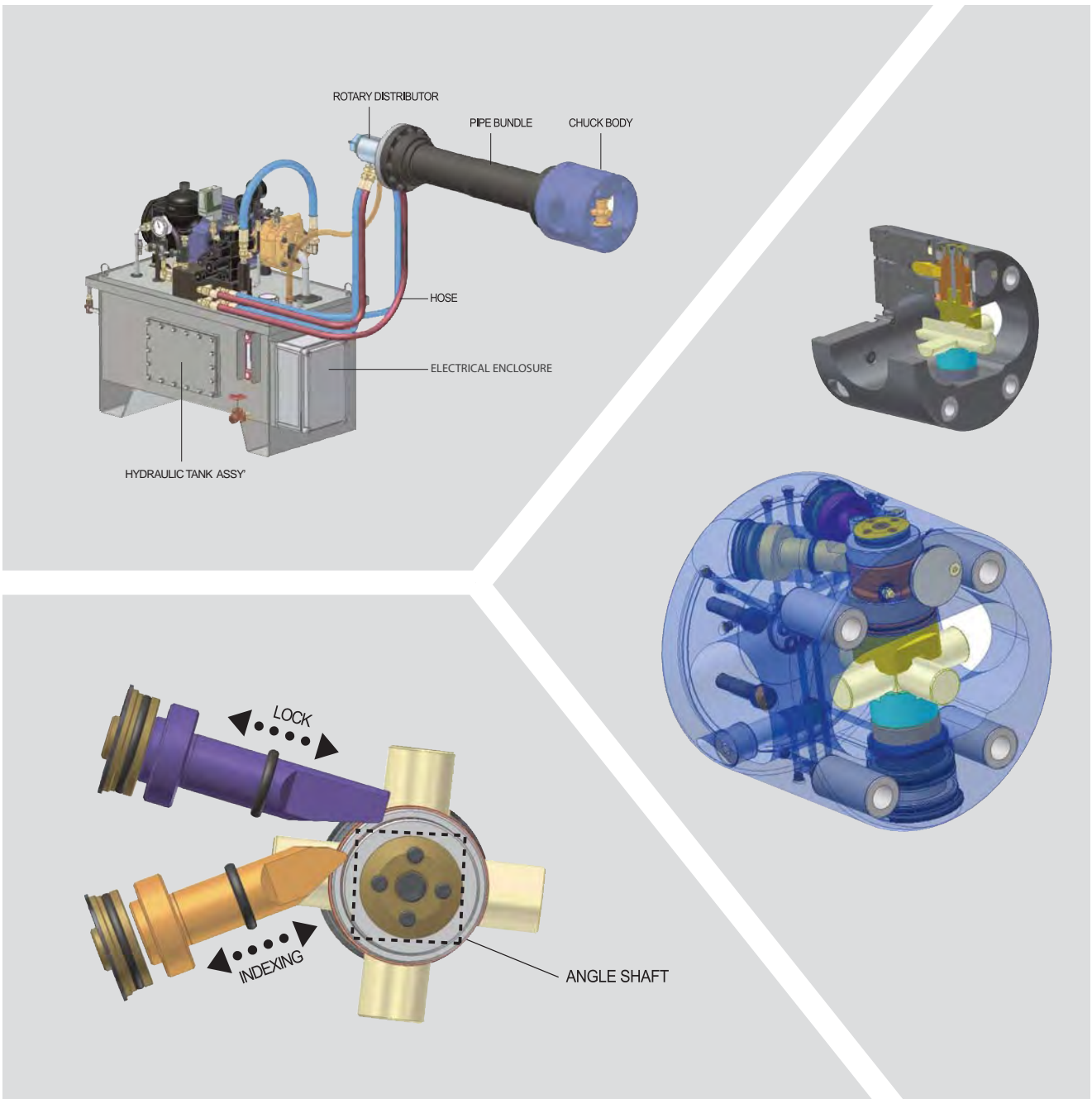

Work Pieces



IAN Auto-Indexing Chuck



Application / Benefits

Machine multiple surfaces in a single clamping

Technical features

Accurate, durable indexing system

Index positions 3 x 120° / 4 x 90°

Confirmation of index position via proximity switches

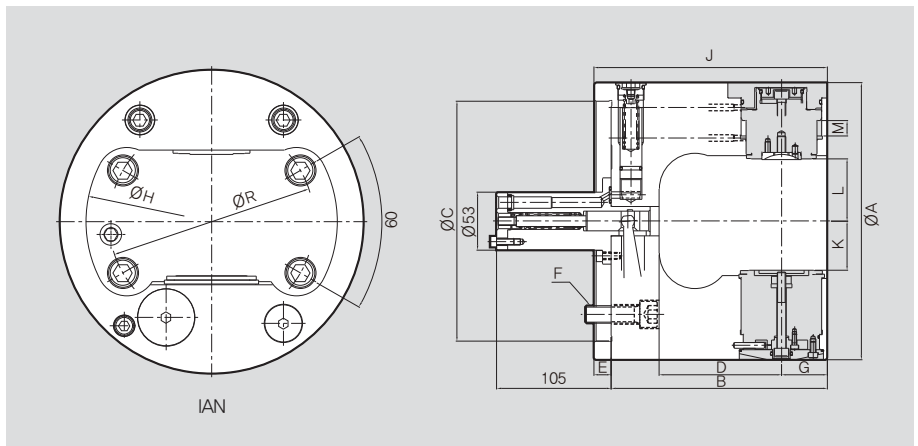

DIMENSIONS

	IAN-235	IAN-254	IAN-280
ØA	235	254	280
B	172	198	211
ØC(h7)	170	220	220
D	102	112	125
E	16	16	16
F	M12	M16	M16
G	30	42	42
ØH	206	228	250
J	188	214	227
K	42.5	45	58
L	54.5	57	70
M	15	17	17
R	133.4	171.4	171.4

SPECIFICATIONS

	IAN-235	IAN-254	IAN-280
Clamp Piston Area [cm ²]	30	43	43
Max. Pressure [kgf·m ²]	45	45	45
Max. Speed [r.p.m.]	3000	2500	2300
Weight [kg]	32	45	55
GD2 [kgf·m ²]	0.27	0.47	0.88

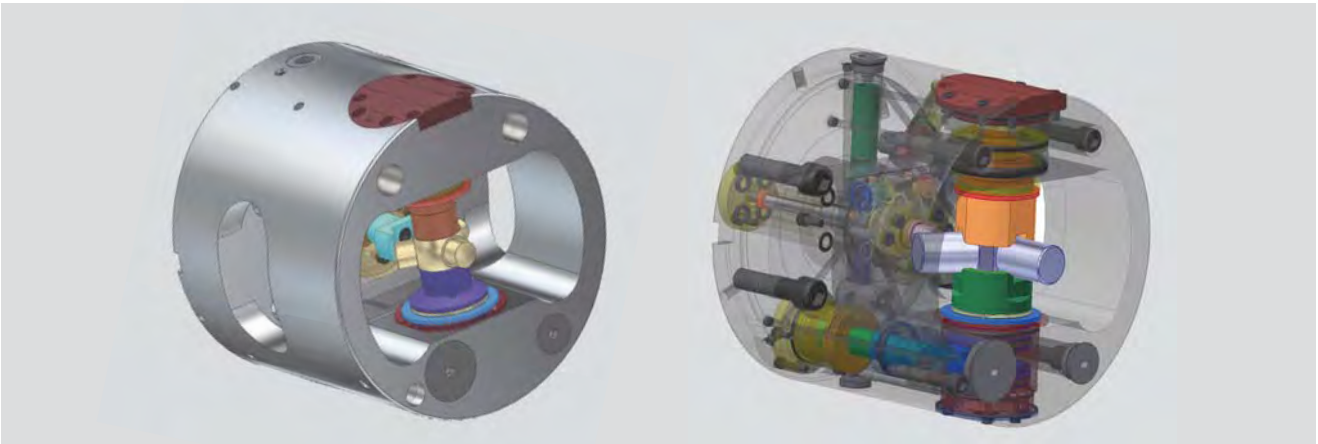
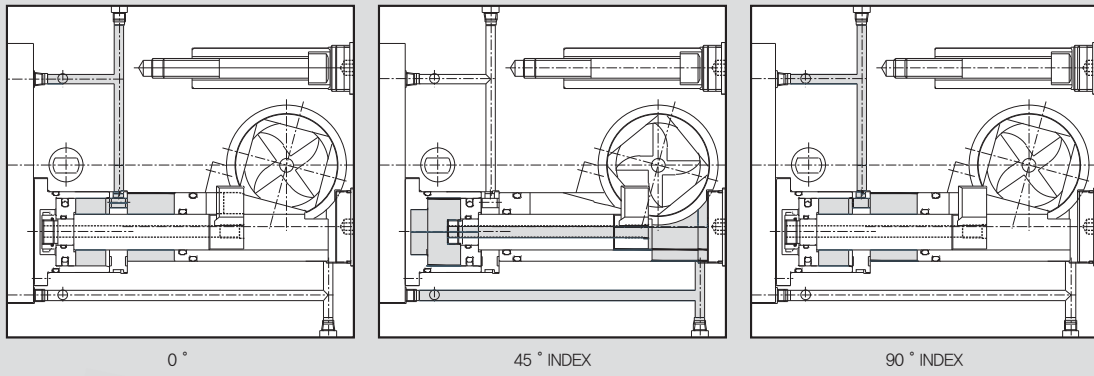

Work Pieces



PHD Outside Pull-Down Chuck



Application / Benefits

TOD clamping chuck ideal for parts with small gripping surfaces.
High accuracy to hold parallel and perpendicular tolerances.

Technical features

Chuck will center the workpiece, then chuck body will pull back to locate workpiece on fixed locator stop(s)

SPECIFICATIONS

	PHD-200	PHD-250	PHD-300	PHD-380
Max. Clamping Force [kgf]	8100	11000	13500	16500
Max. Drawbar Pull [kgf]	3000	4000	5000	6000
Jaw Stroke Dia. [mm]	8.5	10.5	12	12
Plunger Stroke [mm]	24	30	34	34
Stop Traction [kgf]	200	300	300	450
Max. Speed [r.p.m.]	3500	3000	2500	200
Weight [kg]	21	37	54	95

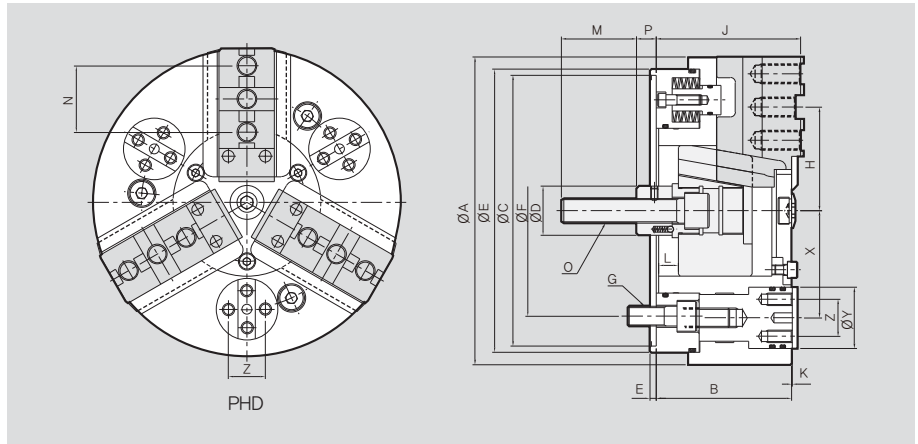
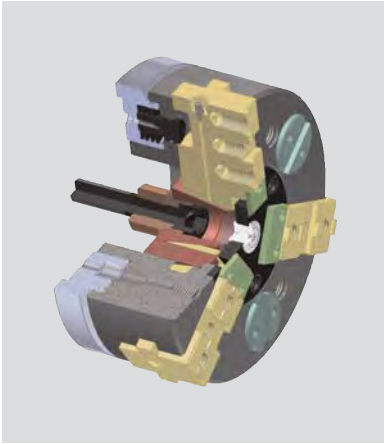

DIMENSIONS

	PHD-200	PHD-250	PHD-300	PHD-380
ØA	200	250	300	380
B	105	115	123	135
ØC(h7)	170	220	220	300
ØD	40	40	50	50
ØE	5	5	5	5
ØF	133.4	171.4	171.4	235
G	M12	M16	M16	M20
Hmax.	71.5	87	105	133.5
Hmin.	67.3	81.7	99	127.5
J	107	117	125	137
K	1	1	1	1
Lmax.	34	34	34	34
Lmin.	10	4	5	16
M	52	60	60	60
N	44.5	54	63.5	76.2
O	M20	M20	M24	M24
Pmax.	25	31	30	19
Pmin.	1	1	-4	-15
X	70	87	108	130
ØY	42	50	68	80
Z	24	30	40	54

PHDN Inside Pull-Down Chuck



Application / Benefits

ID clamping chuck ideal for parts with small gripping surfaces
High accuracy to hold parallel and perpendicular tolerances

Technical features

Chuck will center the workpiece, then chuck body will pull back to locate workpiece on fixed locator stop(s).

SPECIFICATIONS

	PHDN-200	PHDN-250	PHDN-300	PHDN-380
Max. Clamping Force [kgf]	8100	11000	13500	16500
Max. Drawbar Pull [kgf]	3000	4000	5000	6000
Jaw Stroke Dia. [mm]	8.5	10.5	12.0	12.0
Plunger Stroke [mm]	24	30	34	34
Stop Traction [kgf]	200	300	300	450
Max. Speed [r.p.m.]	3500	3000	2500	200
Weight [kg]	21	37	54	95

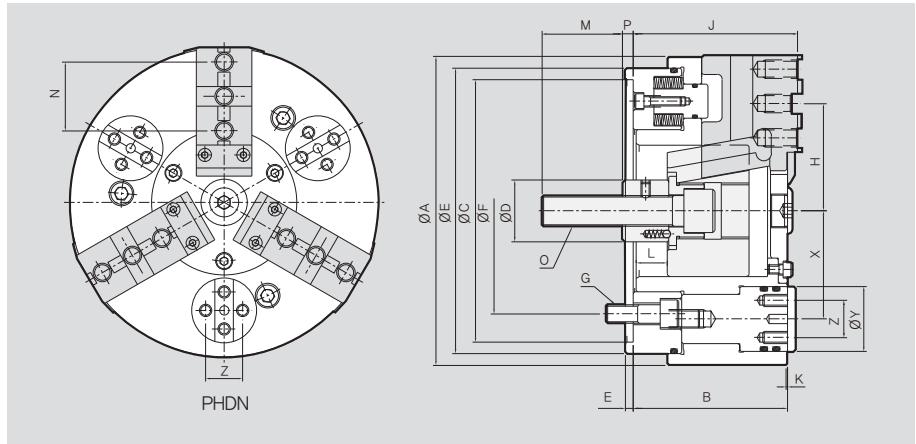
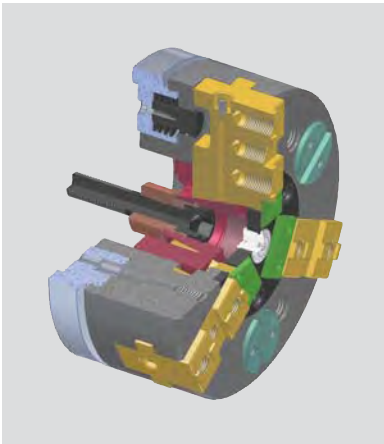

DIMENSIONS

	PHDN-200	PHDN-250	PHDN-300	PHDN-380
ΦA	200	250	300	380
B	105	115	123	135
$\Phi C(h7)$	170	220	220	300
ΦD	40	40	50	50
ΦE	5	5	5	5
ΦF	133.4	171.4	171.4	235
G	M12	M16	M16	M20
Hmax.	71.5	87	105	133.5
Hmin.	67.3	81.7	99	127.5
J	107	117	125	137
K	1	1	1	1
Lmax.	34	34	39	50
Lmin.	10	4	5	16
M	52	60	60	60
N	44.5	54	63.5	76.2
O	M20	M20	M24	M24
Pmax.	15	24	23	19
Pmin.	-9	-6	-11	-15
X	70	87	108	130
ΦY	42	50	68	80
Z	24	30	40	54

RS Retractable-Jaw Shaft Chuck



Application / Benefits

Machining of shafts with 1 setup

Technical features

Jaws clamp on shaft during OD and facing operation.
 Jaws then retract and face driver engaged to finish OD.
 Requires dual piston cylinder

SPECIFICATIONS

	RS-200	RS-250	RS-300
Max. Clamping Force [kgf]	4000	6500	10000
Max. Drawbar Pull [kgf]	3800	6000	8000
Clamping Range [mm]	Chuck	25~110	40~140
	Face Driver	12~70	12~100
Max. Speed [r.p.m.]	4000	3500	2500
Weight [kg]	35	60	100
GD2 [kgf·m ²]	0.19	0.79	1.35

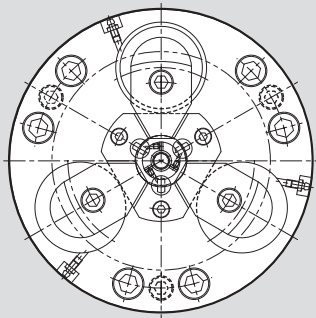

IAH

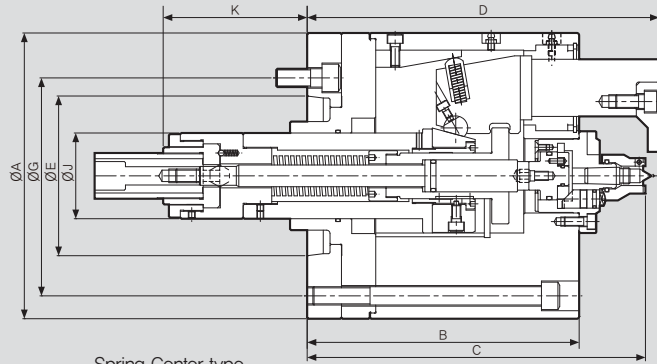

Spring Center type

DIMENSIONS

	RS-200	RS-250	RS-300
ØA	200	250	300
Bmax.	164	205	205
Bmin.	139	173.5	173.5
C	192	240	240
Dmin.	205	252.5	252.5
Dmin.	190	221	221
ØE	106.375	139.719	139.719
ØG	133.4	171.4	171.4
H	3xM12	3xM16	3xM16
ØJ	50	60	80
Kmax.	96.5	109.5	114.5
Kmin.	58.5	62.5	67.5
L	M16	M20	M24
M	30	45	50
Pmax.	41.5	49.5	49.5
Pmin.	3.5	2.5	25
Q	M34x0.5	M40x0.5	M50x0.5
R	30	35	40
Smax.	92	105	110
Smin.	82	95	100
T	12.5	16.5	13.5
U	10	10	10
V	M12	M16	M16
W	30	37	37

CSF Compensating Chuck



Application / Benefits

A spherical bearing enables the jaws to compensate for high-precision work on rounded surfaces

Technical features

Jaws float on spherical bearing to determined clamping points
Spring or fixed center available, All three jaws apply constant gripping force

SPECIFICATIONS

	CSF-07	CSF-08	CSF-12
Static Clamping force [kgf]	2600	3200	4400
Max. Drawbar Pull [kgf]	1500	2100	2700
Jaw Stroke Dia. [mm]	16	20	25
Plunger Stroke [mm]	20	25	30
Min. Chucking Dia. [mm]	20	25	30
Max. Runout Dia. [mm]	4	4	6
Max. Speed [r.p.m.]	4000	3200	2000
Spring Force [kgf]	45	52	106
Weight [kg]	15	28	58
GD2 [kgf·m ²]	0.25	0.8	3.13

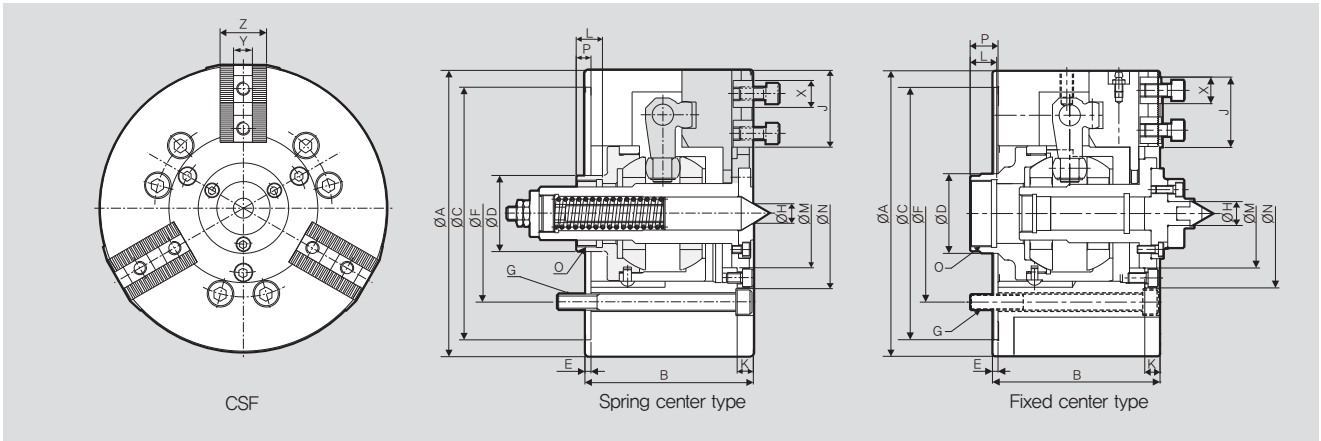

DIMENSIONS

	CSF-07	CSF-08	CSF-12
ØA	170	215	280
B	99	126.2	154.7
ØC(h7)	140	190	255
ØD	42	57	72
ØE	4	4.2	5.7
ØF	104.8	133.4	171.4
G	3-M10	6-M12	6-M16
ØH	11	15	20
J	45	57.5	72
K	11	13	17
L	20	20	26
ØM	65	82	110
ØN	86	112.1	142.2
O	M34xP1.5	M50xP1.5	M60xP1.5
Pmax.	28.2	34	44
Pmin.	8.2	9	14
X	16	20	26
Y	11	14	20
Z	28	35	45

FWC Aluminum Wheel Chuck



Application / Benefits

Ideal for machining the aluminum wheels used on cars and motorcycles
Improving the productivity with lower weight and moment of inertia(GD^2)

Technical features

Finger clamping type of cam arm structure has strong clamping force.
Lower weight increases efficiency and reduces down time.

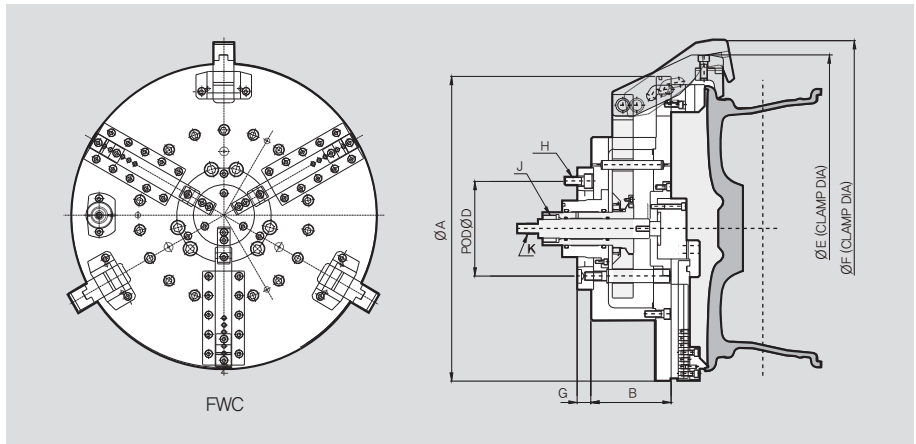
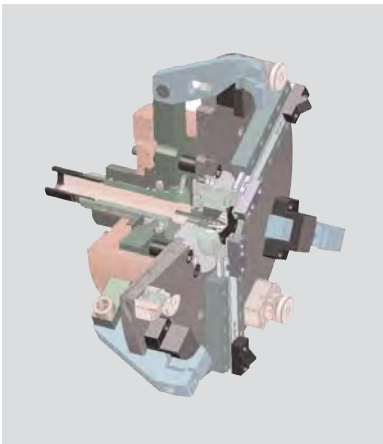

DIMENSIONS

JAW		A	B	C	D	
FWC-300	Cam Arm	S	12	13	14	15
		M	13	14	15	16
		L	14	15	16	17
		XL	15	16	17	18
JAW		A	B	C	D	
FWC-310	Cam Arm	S	13	14	15	16
		M	14	15	16	17
		L	15	16	17	18
		XL	16	17	18	19
		XXL	17	18	19	20
JAW		A	B	C	D	
FWC-320	Cam Arm	S	17	18	19	20
		M	18	19	20	21.5
		L	19	20	21.5	22.5

	FWC-300	FWC-310	FWC-320
ØA	495	550	660
B	139.7	145	199.5
C(h6)	139.719	196.87	196.87
ØD	171.45	235	235
E	Flexible	Flexible	Flexible
F	Flexible	Flexible	Flexible
G	25	35	35
H	M16	M20	M20
J	M42	M42	M42
K	M24	M24	M24

SPECIFICATIONS

	FWC-300	FWC-310	FWC-320
Max. Clamping Force [kgf]	970	970	970
Max. Drawbar Pull [kgf]	3000	3000	3000
Jaw Stroke Dia. [mm]	27	27	27
Plunger Stroke [mm]	35	35	35
Wheel Size Range [inch]	12~18	13~20	17.5~24.5
Max. Speed [r.p.m.]	2800	2200	1800
Weight [kg]	120	160	240
GD2	2.4	3.5	7.5

	FWC-300	FWC-310	FWC-320	
Wheel Size [inch]	12"	○		
	13"	○	○	
	14"	○	○	
	15"	○	○	
	16"	○	○	
	17"	○	○	○
	18"	○	○	○
	19"		○	○
	20"		○	○
	21.5"			○
	22.5"			○

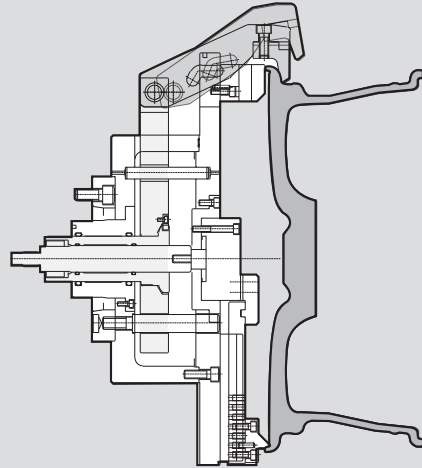

(OP#10)

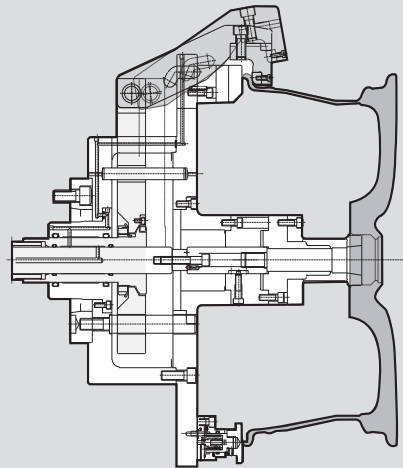
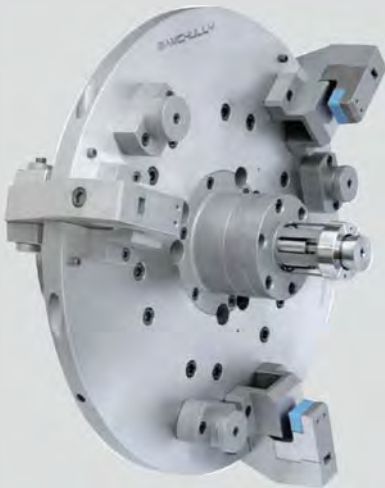

(OP#20)



POWER CHUCK

Through Reliability and high quality, Samchully power chucks retain the trust of machine tool builders as their preferred standard.

High precision coupled with wide selection, our power chucks continue to be the foundation for perennial success.



IDF

Self centering 2+2
Jaw Power Chuck

40 P



HS-A (Adaptor)

3-jaw High-Speed
Open Center Chuck

58 P



HC

3-jaw Close Center
Chuck

80 P



UR

Mega Bore 3-Jaw
High-Speed Open
Center Chuck

44 P



HST/F

2, 4-jaw High-Speed
Open Center Chuck

62 P



HC-A (Adaptor)

3-jaw Close Center
Chuck

86 P



QJC

Quick Jaw
Change Chuck

46 P



HSL (Long Stroke)

3-jaw High-Speed
Open Center Chuck

64 P



HCT/F

2, 4-jaw Close
Center Chuck

90 P



PAC

Mega-Bore
Pneumatic Self-
Contained Chuck

48 P



MH

Mega-Bore 3-jaw
High-Speed Open
Center Chuck

66 P



HC-SE

3-jaw Sealed Close
Center Chuck

94 P



RTC

Rotary Table Chuck

50 P



MHT/F

Mega-Bore 2, 4-jaw
High-Speed Open
Center Chuck

68 P



HCL (Long Stroke)

3-jaw Close Center
Chuck

96 P



MCA

Stationary
Pneumatic Chuck

52 P



HCH

3-jaw Open Center
Chuck

70 P



HCLT/F (Long Stroke)

2, 4-jaw Open
Center Chuck

98 P



MCH

Stationary
Hydraulic Chuck

54 P



HCH-A (Adaptor)

3-jaw Open Center
Chuck

74 P



HCWF

4-jaw Double
Wedge Hydraulic
Chuck

100 P



HS

Standard 3-jaw High-
Speed Open Center
Chuck

56 P



HCHT/F

2, 4-jaw
Open Center Chuck

78 P

IDF

Self centering 2+2 Jaw Power Chuck

Performance and quality are much better than standard 3-jaw configurations.
4-Jaw(2+2) Chuck requires dual-piston cylinder, but IDF is compatible with existing cylinder(100%)

Power Chuck

STRUCTURE

① Jaw Lever	④ Plunger
② Seesaw	⑤ Weight
③ Wedge Bar	⑥ Master jaw

PRINCIPLE

1. 2+2 Jaw
: ①+③ & ②+④ Self-centering
2. 2+2 Jaw chuck with 2 independent self-centering jaws
3. Counter balancing weights provide centrifugal force compensation
4. Lever type

Patent 10-2014-0092073

01/ Cost-saving compatibility with standard cylinders

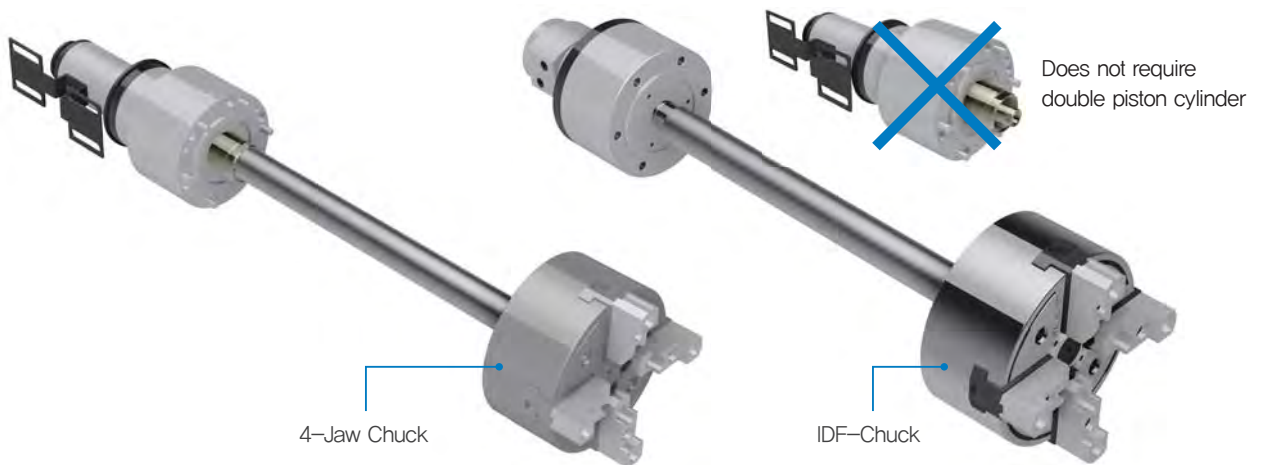

02/ Better performance than standard 3-jaw



Decreased 1/10 For Floating Range

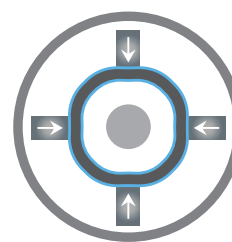
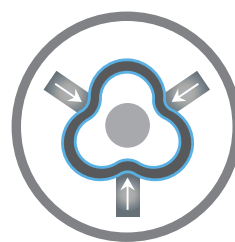

1/3 For Deformation Of Thin Work Piece

03/ Easy to measure the workpieces after jaw boring

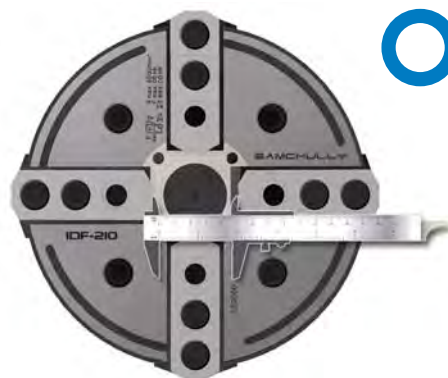
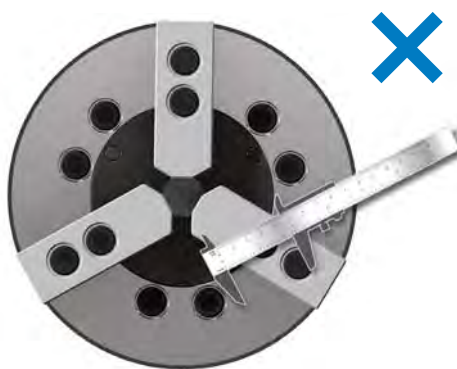

04/ Use irregular workpieces without interchanging chuck



IDF Self centering 2+2 Jaw Power Chuck



Application / Benefits

High precision self-centering 4-Jaw power chuck(2+2 Jaw)

Technical features

Self-centering in two axes
Single wedge actuation does not require dual-piston cylinder
2+2 Jaw chuck with 2 independent self-centering jaws

ACTUAL GRIPPING FORCE DIAGRAM

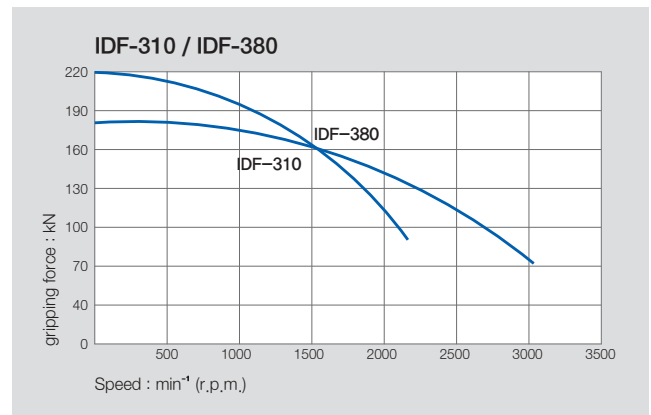
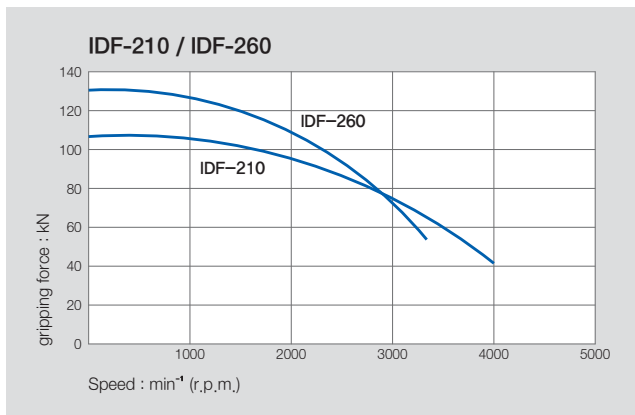

※ When using taller heavier jaw or clamping on a bigger diameter reduce draw pull rotating speed accordingly.

SPECIFICATIONS

	IDF-210	IDF-260	IDF-310	IDF-380
Jaw Stroke Radial. [mm]	5.2	6.2	6.2	6.2
Compensation [mm]	± 2	± 2	± 2	± 2
Plunger Stroke [mm]	10	12	12	12
Max. Permissible Input Force [kN(kgf)]	40(4081)	50(5102)	70(7143)	80(8163)
Max. Static Gripping Force [kN(kgf)]	100(10204)	130(13265)	180(18367)	220(22448)
Max. r.p.m. [min ⁻¹]	4000	3200	3000	2100
Operating Cylinder	Y-1225RE	Y-1530RE	Y-1530RE	Y-2035RE
Weight [kg]	24	43	68	110
Moment of inertia [kg · m ²]	0.14	0.39	0.88	2.2

※ Maximum turning speed is based upon actual measurement.

※ Specifications are subject to change without notice.

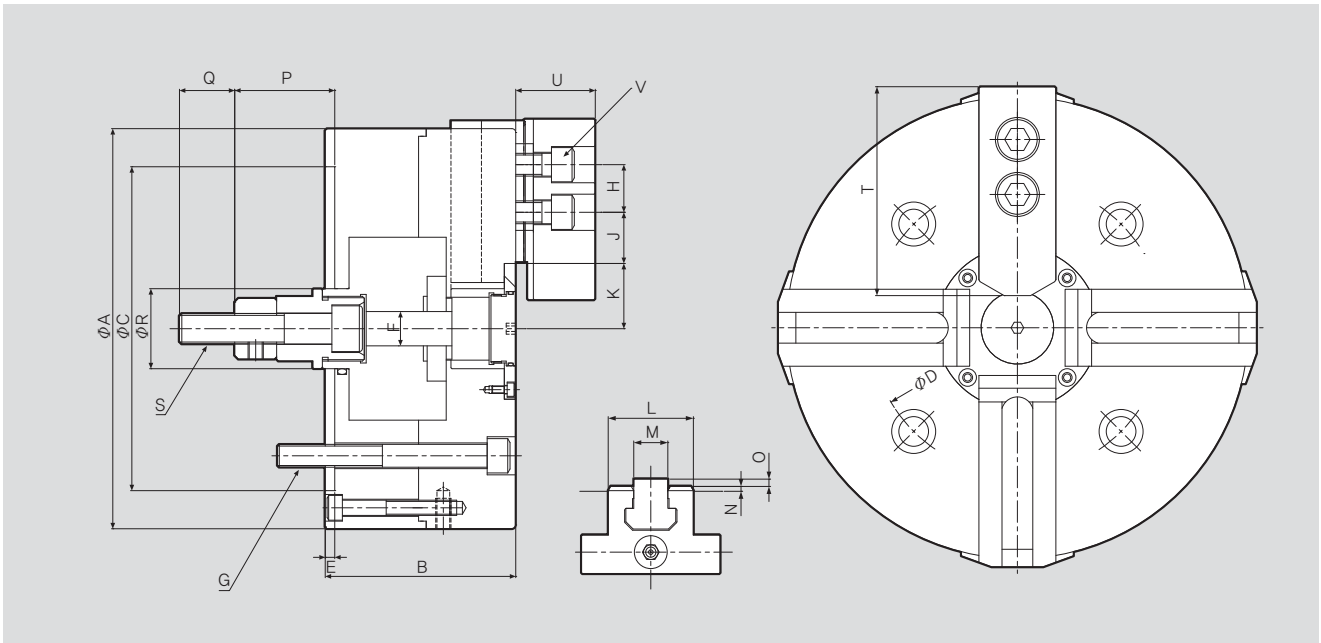

※ It is recommended to grease chucks at least twice a day in order to maximize longevity.

DIMENSIONS

	IDF-210	IDF-260	IDF-310	IDF-380
ΦA	210	260	310	380
B	100	120	127	135
ΦC (기준경)	170	220	220	300
ΦD	133.4	171.4	171.4	235
E	5	5	5	5
F	24	30	30	40
G	M12	M16	M16	M20
H	25	30	30	43
J (Max/Min)	39/10	45/13	58/13	53/18
K (Max/Min)	34.2/29	46.2/40	53.2/47	74.2/68
L	35	40	50	62
M	14	16	18	25.5
N	5	5	5	5
O	3	3	3	3
P (Max/Min)	52/62	53/65	53/65	93/81
Q	29	33	33	33
R	42	50	55	55
S	M16x80	M20x80	M20x80	M30x125
T	95	98	115	135
U	42	46	54	64
V	M12x30	M12x35	M14x45	M20x45

RELATED PRODUCT



UR Mega Bore 3-Jaw High-Speed Open Center Chuck



Application / Benefits

For work requiring through-hole
Choose between metric or inch serrated jaws

Technical features

Case hardened body to assure high precision and longevity
Wedge style enables high clamping force

ACTUAL GRIPPING FORCE DIAGRAM

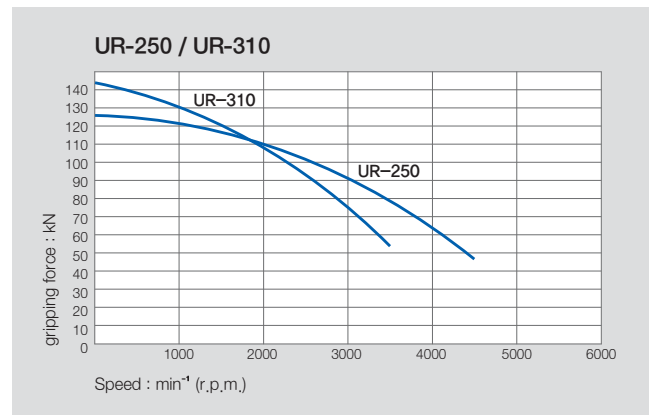
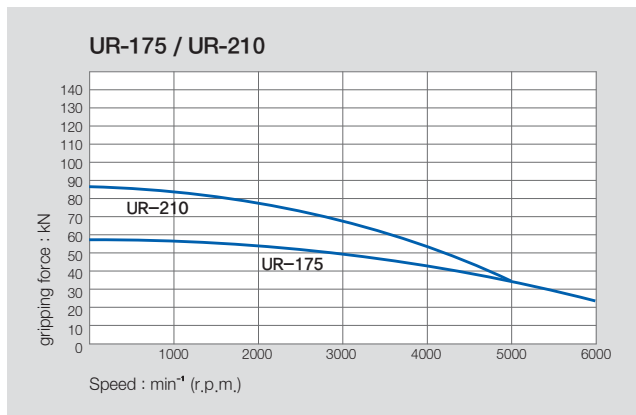

※ Results reflect gripping force when using standard Samchully soft jaws, Variations in size of jaw and workpiece may decrease gripping force.

SPECIFICATIONS

	UR-175	UR-210	UR-250	UR-315
Thru Hole Dia. [mm]	56	66	82	122
Grip Dia. Max. [mm]	175	210	254	315
Grip Dia. Min. [mm]	16	23	30	74
Jaw Stroke Dia. [mm]	6.4	8.0	10.0	10.6
Plunger Stroke [mm]	14	17.5	22	23
Max. Permissible Input Force [kN(kgf)]	25(2551)	38(3878)	50(5102)	50(5102)
Max. Static Gripping Force [kN(kgf)]	70(7143)	108(11020)	145(14796)	145(14796)
Max. r.p.m. [min ⁻¹]	6000	5000	4000	3200
Weight [kg]	11	19.5	30	42
Moment of inertia [kg · m ²]	0.05	0.12	0.27	0.60
Operating Cylinder	SD-15452	SD-17568	SD-18582	SD-30516
Max. Hydraulic Pressure [MPa(kgf/cm ²)]	1.8(18.35)	2.5(25.49)	2.8(28.55)	1.4(14.27)

※ Specifications are subject to change without notice.

Thru Hole Range : $\varnothing 56 \sim \varnothing 122$
Clamping Range : $\varnothing 16.5 \sim \varnothing 315$

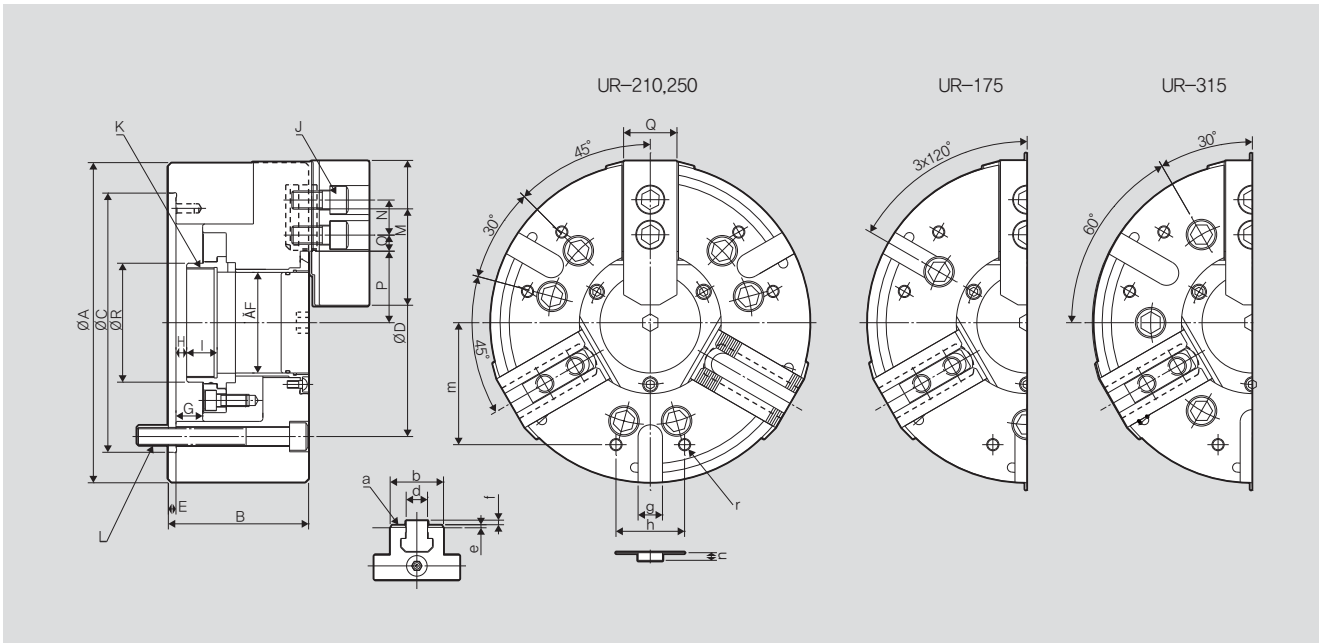

※ It is recommended to grease chucks at least twice a day in order to maximize longevity.

DIMENSIONS

	UR-175	UR-210	UR-250	UR-315
ΦA	175	210	254	315
B	81	92	103	115
ΦC (기준경)	160	170	220	300
ΦD	133.4	133.4	171.4	235
E	5	5	5	5
F	56	66	82	122
G	14	17.5	22	23
H (max./min.)	4 / -10	7 / -10.5	13 / -9	19 / -4
I	18	20	20	23
J (UR-D/UR-M)	M10 / M10	M12 / M12	M12 / M12	M16 / M16
K (max)	M62x1.5P	M72x1.5P	M85x2.0P	M125x2.0P
L	M12	M12	M16	M20
M	70	95	110	125
N (UR-D/UR-M)	16.5 / 20	23 / 25	30 / 30	30 / 30
O (max./min.)	22 / 10	23 / 11	32 / 14	37 / 15
P (max./min.)	38/35	47/43	57/62	81/76
Q	31	35	40	50
R	71	78	92	143
a (UR-D/UR-M)	1/16"x90° / 1.5x60°	1/16"x90° / 1.5x60°	1/16"x90° / 1.5x60°	1/16"x90° / 1.5x60°
b	33	38	45	45
d (UR-D/UR-M)	12 / 14	17 / 14	21 / 16	21 / 21
e	3	3	4	4
f	2.5	2.5	3.5	3.5
g	16	16	16	20
h	36	45	60	60
m	65	80	102	100
n	5	5	5	5
r	M8	M8	M10	M10

※ Blank and machined draw-nuts are available.

RELATED PRODUCT



QJC Quick Jaw Change Chuck



Application / Benefits

- Minimal set-up times ; change jaws within a minute
- Reversible jaws
- High repeatability of < 0.02mm
- No reboring required

Technical features

- Wedge bar system minimizes loss of gripping force
- Built-in safety feature ensures jaw serration engagement

ACTUAL GRIPPING FORCE DIAGRAM

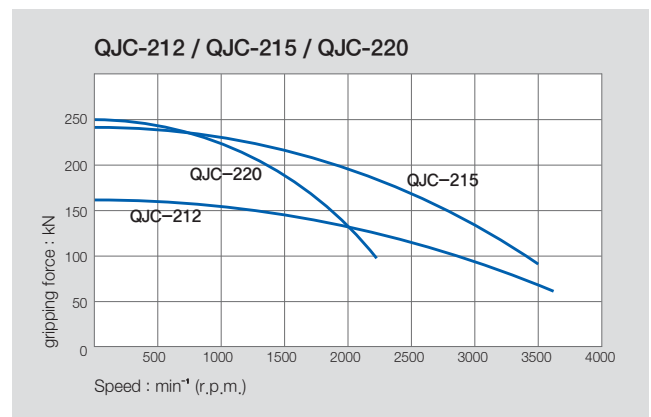
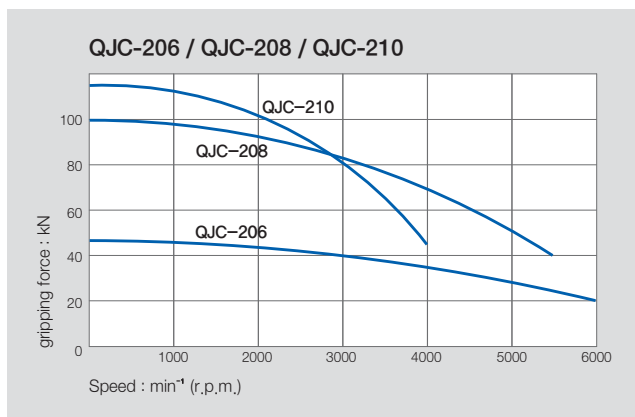

SPECIFICATIONS

	QJC-206	QJC-208	QJC-210	QJC-212	QJC-215	QJC-220
Jaw Stroke Dia. [mm]	11.4	14.4	16	16	17	20
Plunger Stroke [mm]	20	25	28	28	32	42
Permissible Input Force [kN(kgf)]	30(3059)	54(5404)	65(6628)	90(9177)	133(13562)	120(12236)
Max.static Gripping Force [kN(kgf)]	45(4538)	100(10197)	115(11726)	160(16315)	240(24473)	250(25492)
Max. r.p.m. [min ⁻¹]	6000	5500	4000	3600	3500	2200
Weight [kg]	13	24	42	66	109	225
Moment of inertia [kg · m ²]	0.11	0.11	0.41	0.97	2.3	6.5
Operating Cylinder	SD-13546	SD-17568	SD-18582	SD-21511	SDL-25411	SDL-30516
Max. Hydraulic Pressure [MPa(kgf/cm ²)]	3.0(30.5)	3.0(35.6)	3.7(37.7)	4.0(40.7)	4.0(40.7)	2.9(29.5)

Thru Hole Range : $\varnothing 45 \sim \varnothing 155$
Clamping Range : $\varnothing 15 \sim \varnothing 400$

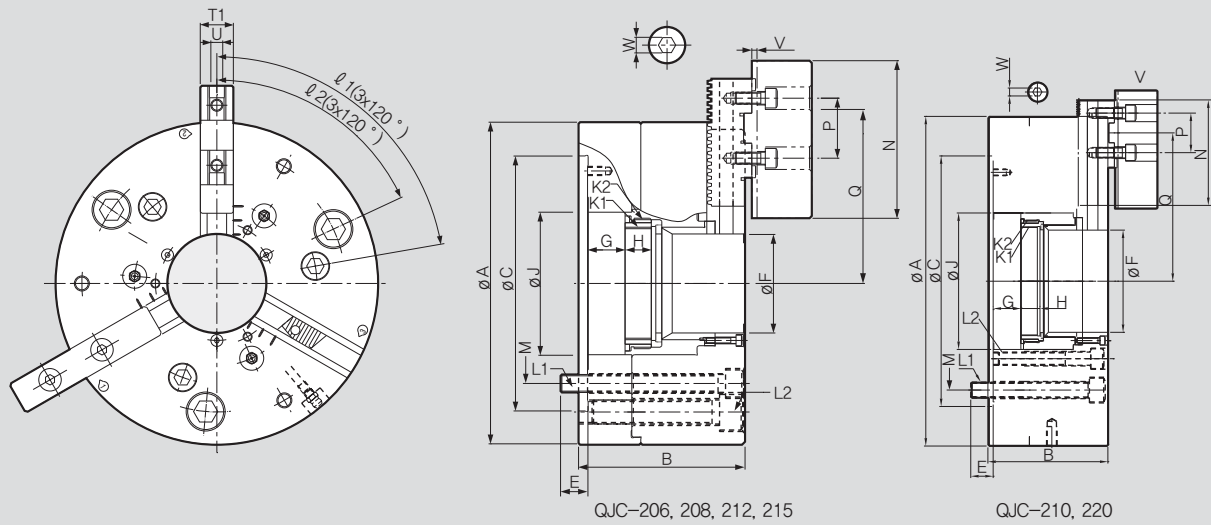

※ It is recommended to grease chucks at least twice a day in order to maximize longevity.

DIMENSIONS

	QJC-206	QJC-208	QJC-210	QJC-212	QJC-215	QJC-220
ΦA	165	215	260	315	400	500
B	95	111	129.3	138.1	144	182
ΦC (기준경)	140	170	220	220	300	380
E	14	18	23.7	24.9	25	34
ΦF	45	66	81	104	128	155
G max.	20.2	25	28	28.5	32	42
G min.	0	0	0	0	0	0
H	15	17.5	22	23.2	22	29
ΦJ	68	95	114	148	180	207
K1	M50	M75	M90	M115	M138	M165
K2	M60	M87	M105	M135	M160	M185
L1	3-M10	3-M12	3-M16	3-M16	3-M20	3-M24
L2	3-M12	3-M16	3-M12	3-M20	3-M24	3-M20
$i1$	80°	80°	80°	80°	70°	85°
$i2$	20°	65°	65°	70°	60°	75°
M	104.8	133.35	171.4	171.4	235	330.2
N	85	97	125	125	145	160
P	32	40	40	40	54	60
Q max.	76.8	118.3	129.7	159.1	182.4	225
Q min.	58	71.2	102.2	106.9	121.9	141
T1	20	22	30	30	35	45
T2	20	22	26	32	32	48
U	8	10	12	12	12	18
V	2.5	2.5	3	3	3	4
W	8	10	10	10	10	12

※ Blank and machined draw-nuts are available.

RELATED PRODUCT

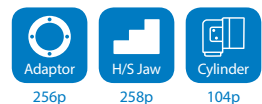

PAC Mega-Bore Pneumatic Self-Contained Chuck



Application / Benefits

Suitable for large pipe machining
Utilizes full spindle through hole

Technical features

Self-contained air chuck with check valve
Maintains pressure during power outage

ACTUAL GRIPPING FORCE DIAGRAM

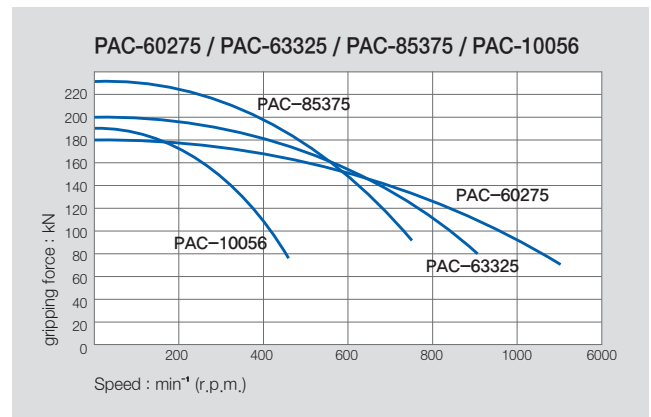
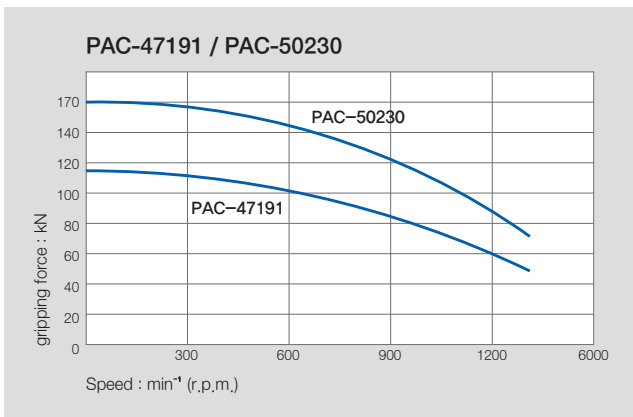

SPECIFICATIONS

	PAC-47191	PAC-50230	PAC-60275	PAC-63325	PAC-85375	PAC-10056
Thru Hole Dia. [mm]	191	230	275	325	375	560
Jaw Stroke Dia. [mm]	20	25.4	25.4	25.4	25.4	25.4
Rapid	13	16.9	16.9	16.9	13.4	15
Clamp	7	8.5	8.5	8.5	12	10.4
Operating Pressure [MPa]	0.2~0.8	0.2~0.8	0.2~0.8	0.2~0.8	0.2~0.8	0.2~0.8
Clamping Force [kN]	115	170	180	200	230	190
Max. r.p.m. [min ⁻¹]	1300	1300	1100	900	750	450
Weight [kg]	190	325	355	630	970	960
Moment of inertia [N · m ² (kg · m ²)]	9.8	16.1	20.6	35.1	105	157.6

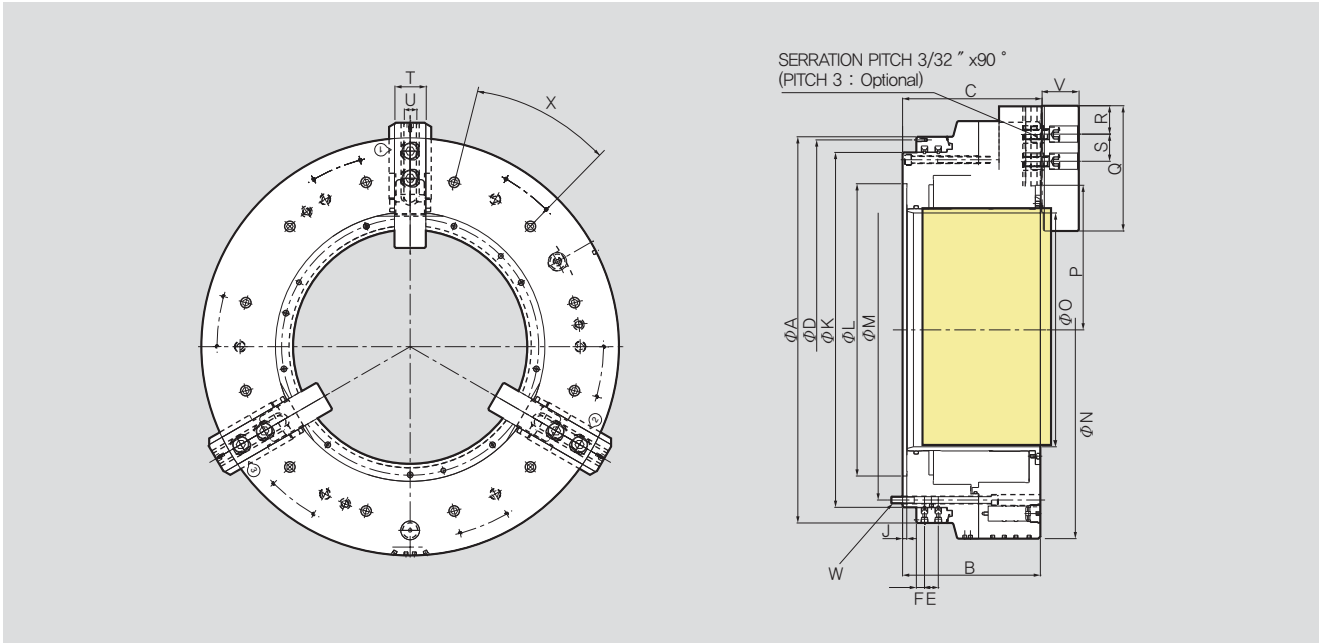

※ It is recommended to grease chucks at least twice a day in order to maximize longevity.

DIMENSIONS

	PAC-47191	PAC-50230	PAC-60275	PAC-63325	PAC-85375	PAC-10056
ΦA	470	570	605	685	850	1000
B	238	280	280	305.5	352	330
C	240	282	284	329.5	356	334
ΦD	448	550	585	666	830	910
E	26	26	26	33	33	33
F	17	17	17	19	19.5	19.5
J	8	8	8	8	8	10
ΦK	400	500	535	610	775	850
ΦL(기준경)	310	415	450	510	700	700
ΦM	374	474	508	580	745	815
ΦN	470	570	605	685	850	1000
ΦO	191	230	275	325	375	560
P Max.	147	180.5	205.9	230.9	268	346.3
P Min.	127	156	180.5	205.5	268	321.1
Q	170	195	195	240	300	300
R	25	37	37	42	68	68
S	40	40	40	65	65	65
T	60	60	60	75	75	75
U	25.5	25.5	25.5	30	30	30
V	60	80	78	80	90	88
W	9-M12	12-M12	12-M12	12-M16	12-M16	12-M16
X	40°	30°	30°	30°	30°	30°

RTC Rotary Table Chuck



Application / Benefits

Suitable for indexing
Soft jaws compatible with standard power chucks

Technical features

Sealed against coolant and chips
Built in air cylinder with compact design

SPECIFICATIONS

	RTC-110	RTC-160	RTC-210	RTC-260
Thru Hole Dia. [mm]	8	20	30	43
Jaw Stroke Dia. [mm]	5.2	5.2	6.3	6.3
Plunger Stroke [mm]	11.3	11.5	13.7	13.6
Max. Static Gripping Force [kN(kgf)]	7.5	21	33	48
Max. Pneumatic Pressure [MPa(kgf/cm ²)]	0.7 (7)	0.7 (7)	0.7 (7)	0.7 (7)
Max. r.p.m. [min ⁻¹]	100	72	50	50
Weight (included Soft Jaws) [kg]	7.3	22	27.7	42.5

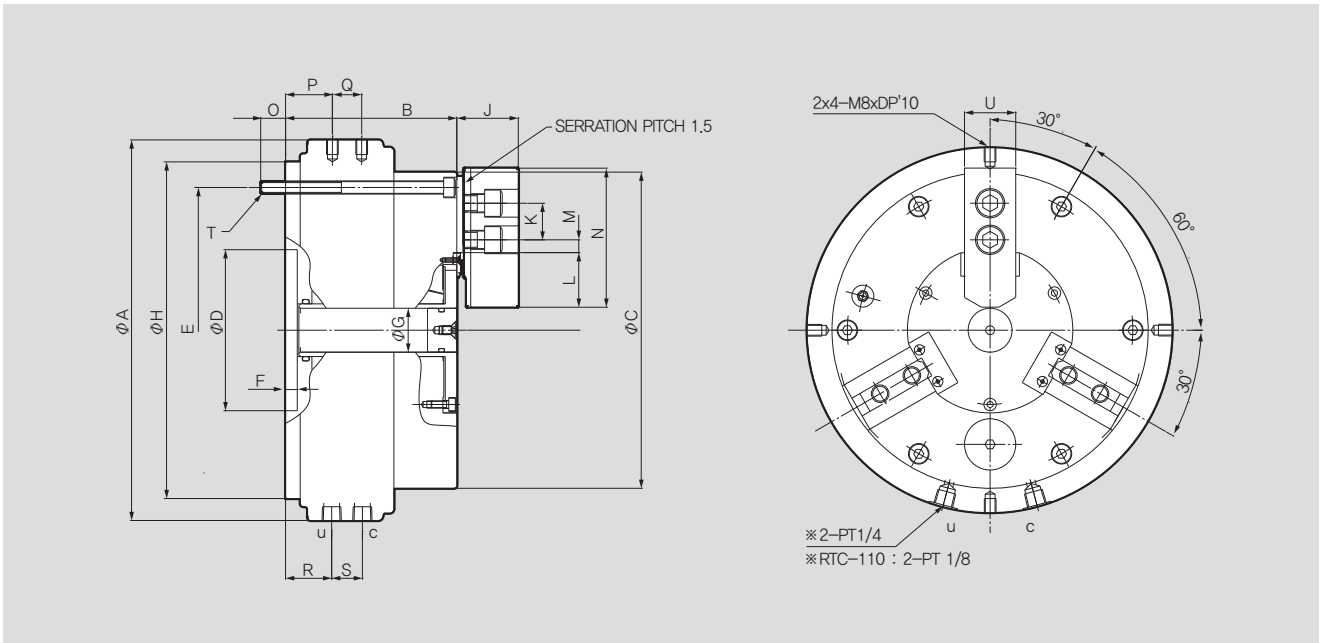

※ It is recommended to grease chucks at least twice a day in order to maximize longevity.

DIMENSIONS

	RTC-110	RTC-160	RTC-210	RTC-260
ΦA	145	210	260	304
B	92	102	117	125
ΦC	113	166	216	264
ΦD (기준경)	80	80	110	140
E	98	148	195	234
F	6	7	8	8
ΦG	8	20	30	43
ΦH	124	175	230	268
J	27	36	42	46
K	14	20	25	30
L max.	32.8	41.9	53	66
L min.	30.2	39.3	49.85	62.85
M max.	5.4	9.25	14.75	16
M min.	2.4	4.75	8.75	8.5
N	55	72	95	110
O	11	15	17	16
P	25.5	31	32	39.5
Q	12.2	18	20	21
R	25.5	32.3	31.5	39.5
S	12.2	15.2	21	21
T	M6x95L	M8x105L	M8x125L	M10x130L
U	23	31	35	40

MCA Stationary Pneumatic Chuck

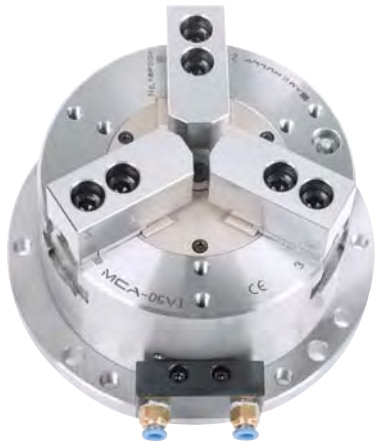

Application / Benefits

Ideal for machining centers

Technical features

Sealed against coolant and chips

Built-in air cylinder with compact design

SPECIFICATIONS

	MCA-04	MCA-06	MCA-08	MCA-10
Clamping Force (Pneumatic 6bar) [kN(kgf)]	7.5(765)	21(2140)	33(3300)	48(4800)
Jaw Stroke Dia. [mm]	5.2	5.2	6.3	6.3
Grip Dia. Max [mm]	110	165	210	254
Grip Dia. Min [mm]	10	23	30	50
Max. Pneumatic Pressure [MPa(kgf/cm ²)]	0.7(7)	0.7(7)	0.7(7)	0.7(7)
Weight [kg]	7.3	16	28	43

Thru Hole Range : $\varnothing 20 \sim \varnothing 43$
Clamping Range : $\varnothing 10 \sim \varnothing 250$

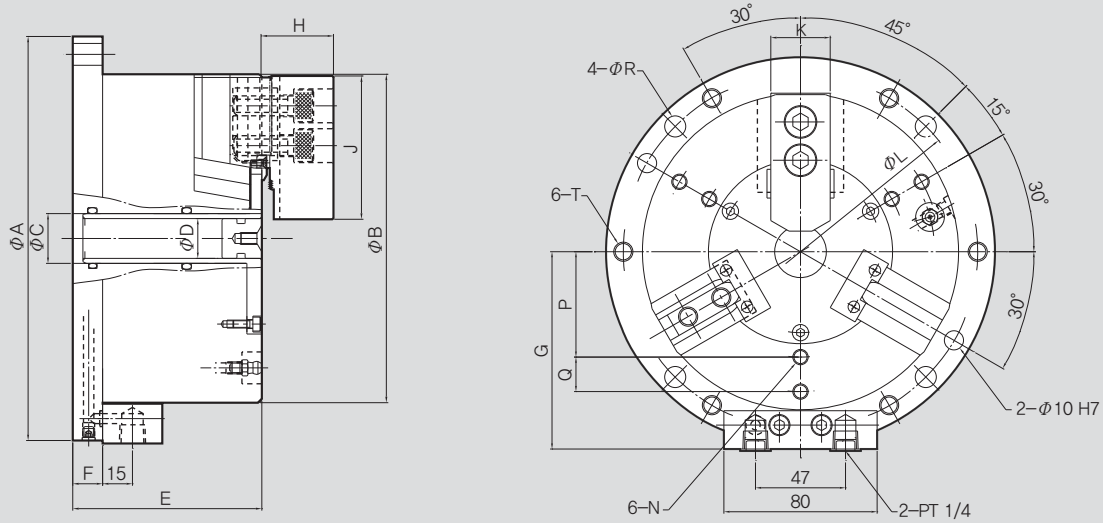

※ It is recommended to grease chucks at least twice a day in order to maximize longevity.

DIMENSIONS

	MCA-04	MCA-06	MCA-08	MCA-10
ΦA	148	203	248	300
ΦB	110	165	210	254
ΦC	20	25	36	50
ΦD	-	20	30	43
E	90	95	106	110
F	15	15	15	16
G	75.5	103	125.5	147.5
H	27	36	42	46
J	55	72	95	110
K	23	31	35	40
N	M8	M8	M8	M10
ΦL (P.C.D)	130	185	230	280
P	-	55	68	80
Q	-	58	68	80
ΦR	9	11	11	13
T	M10	M10	M10	M12

MCH Stationary Power Chuck



Application / Benefits

Ideal for machining centers

Technical features

Sealed against coolant and chips

Built-in hydraulic cylinder with compact design

SPECIFICATIONS

	MCH-06	MCH-08	MCH-10
Clamping Force (25bar) [kN]	55	85	125
Jaw Stroke Dia. [mm]	5.2	6.3	6.8
Grip Dia. Max [mm]	169	210	254
Grip Dia. Min [mm]	15	30	50
Max. Pneumatic Pressure [MPa(kgf/cm ²)]	3(30.5)	3(30.5)	3(30.5)
Weight [kg]	18	30	44

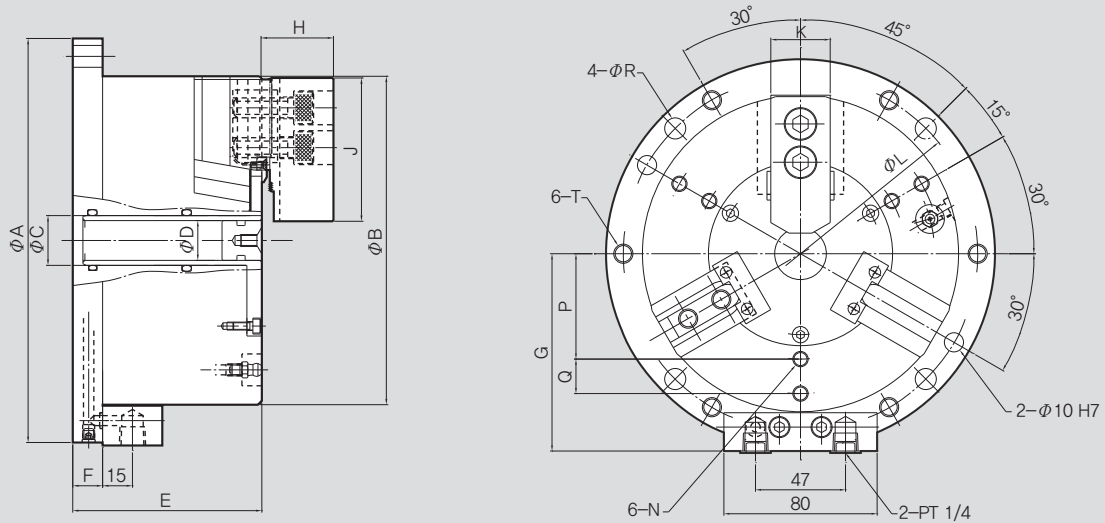

※ It is recommended to grease chucks at least twice a day in order to maximize longevity.

DIMENSIONS

	MCH-06	MCH-08	MCH-10
ΦA	210	255	300
ΦB	165	210	254
ΦC	25	36	50
ΦD	20	30	43
E	100	111	121
F	20	20	20
G	103	125.5	147.5
H	36	42	46
J	72	95	110
K	31	35	40
N	M8	M8	M10
ΦL (P.C.D.)	185	235	280
P	55	68	80
Q	18	25	35
ΦR	11	11	13
T	M10	M10	M12

HS Standard 3-Jaw High-Speed Open Center Chuck



Application / Benefits

For work requiring a through hole

Technical features

Wedge hook style chuck with high gripping force

ACTUAL GRIPPING FORCE DIAGRAM

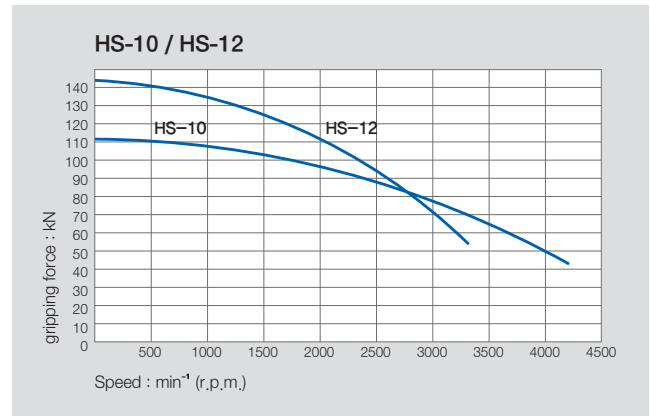
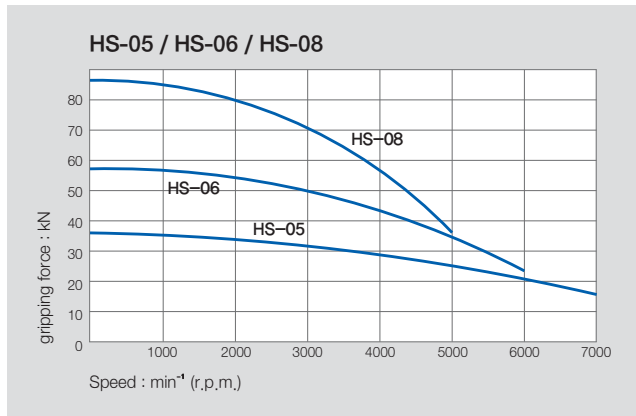

SPECIFICATIONS

	HS-05	HS-06	HS-08	HS-10	HS-12
Thru Hole Dia. [mm]	33	46	52	77	91
Grip Dia. Max [mm]	135	169	210	254	304
Grip Dia. Min [mm]	12	15	13	31	34
Jaw Stroke Dia. [mm]	5.4	5.5	7.4	8.8	10.6
Plunger Stroke [mm]	10	12	16	19	23
Permissible Input Force [kN(kgf)]	17.5(1784)	22(2243)	34.8(3549)	43(4385)	55(5608)
Max. Static Gripping Force [kN(kgf)]	36(3671)	57(5812)	86(8769)	111(11319)	144(14686)
Max. r.p.m. [min ⁻¹]	7000	6000	5000	4200	3300
Weight [kg]	6.7	11.9	22.3	34.5	55.3
Moment of inertia [N · m ² (kg · m ²)]	0.69(0.07)	2.26(0.23)	6.67(0.68)	12.36(1.26)	28.93(2.95)
Operating Cylinder	SH-10036	SH-13046 (SYH-1246)	SH-15052 (SYH-1552)	SH-18077 (SYH-1877)	SYH2091
Max. Hydraulic Pressure [MPa(kgf/cm ²)]	2.9(30)	2.8(28.6)	2.65(27)	2.7(27.5)	2.7(27.5)
Operating Hard Jaw	HB04N1	HB06A1	HB08A1	HB10A1	HB12N1
KITAGAWA® Model	B-205	B-206	B-208	B-210	B-212

※ Specifications are subject to change without notice.

※ Samchully Machinery Co., Ltd. is no longer an OEM manufacturer for Kitagawa® Iron Works Co., Ltd.

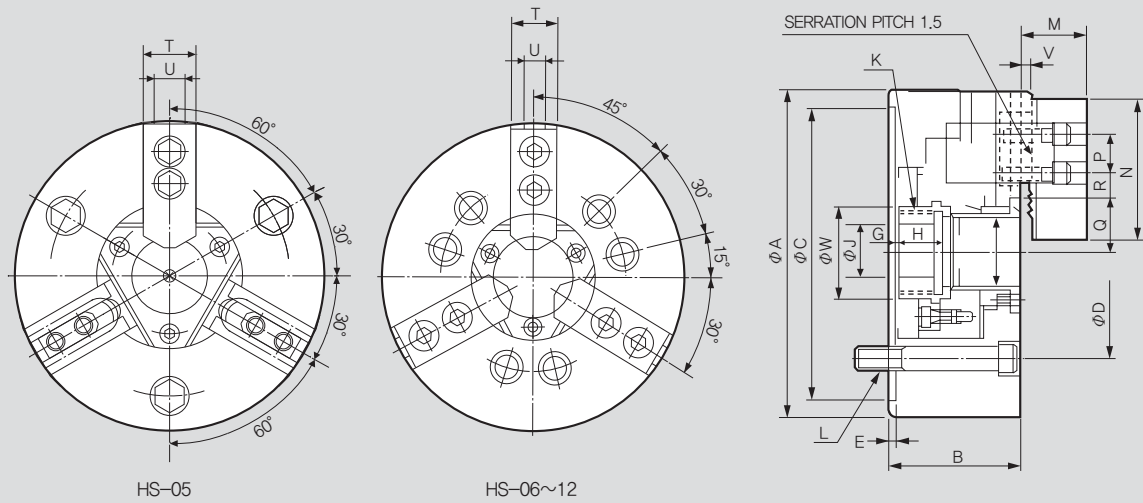

※ It is recommended to grease chucks at least twice a day in order to maximize longevity.

DIMENSIONS

	HS-05	HS-06	HS-08	HS-10	HS-12
ΦA	135	169	210	254	304
B	60	81	91	100	110
$\Phi C(H6)$	110	140	170	220	220
ΦD	82.6	104.8	133.4	171.4	171.4
E	4	5	5	5	6
ΦF	33	46	52	77	91
G max.	1	11	14.5	8.5	8
G min.	-9	-1	-1.5	-10.5	-15
H	20	19	20.5	25	28
ΦJ	12	20	30	45	50
K max.	M40x1.5	M55x2.0	M60x2.0	M85x2.0	M100x2.0
L	3-M10x60	6-M10x95	6-M12x105	6-M16x120	6-M16x130
M	26	29	39	43	50.5
N	54	72	95	110	111
P	14	20	25	30	30
Q max.	26.5	32	38.7	51	61.3
Q min.	23.8	29.25	35	46.6	56
R max.	19.75	22.75	29.75	33.75	45.75
R min.	7.75	9.25	14.75	14.25	15.75
T	23	31	35	40	49
U	10	12	14	16	21
V	2	2	2	2	2
ΦW	45	60	66	94	108

※ Blank and machined draw-nuts are available.

RELATED PRODUCT



HS-A 3-Jaw High-Speed Open Center Chuck with Adaptor (135mm - 210mm)



Application / Benefits

For work requiring a through hole

Technical features

Wedge hook style chuck with high gripping force

ACTUAL GRIPPING FORCE DIAGRAM

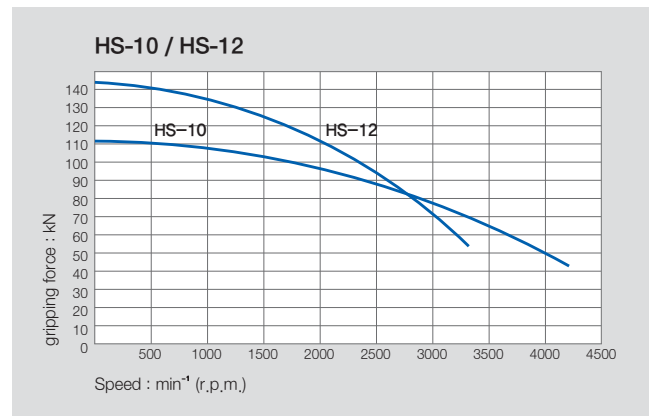
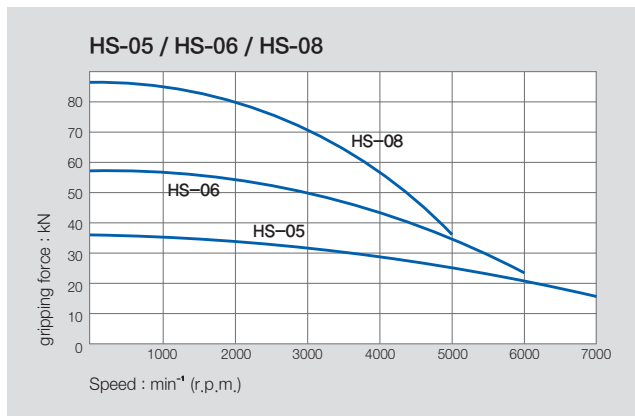

SPECIFICATIONS

	HS-05A05	HS-06A05	HS-08A06
Spindle Nose	A2-5	A2-5	A2-6
Thru Hole Dia. [mm]	33	46	52
Grip Dia. Max [mm]	135	169	210
Grip Dia. Min [mm]	12	15	13
Jaw Stroke Dia. [mm]	5.4	5.5	7.4
Plunger Stroke [mm]	10	12	16
Max. Permissible Input Force [kN(kgf)]	17.5(1784)	22(2243)	34.8(3549)
Max. Static Gripping Force [kN(kgf)]	36(3671)	57(5812)	86(8769)
Max. r.p.m. [min ⁻¹]	7000	6000	5000
Weight [kg]	7.5	13.7	23.6
Moment of inertia [N · m ² (kg · m ²)]	0.687(0.07)	2.45(0.250)	6.9(0.71)
Operating Cylinder	SYH-1036	SH-13046 (SYH-1246)	SH-15052 (SYH-1552)
Max. Hydraulic Pressure [MPa(kgf/cm ²)]	3.43(35.0)	2.8(28.6)	2.65(27)
Operating Hard Jaw	HB04N1	HB06A1	HB08A1
KITAGAWA® Model	B-205	B-206A5	B-208A6

- ※ Specifications are subject to change without notice.
- ※ HS-10A06 and HS-10A08 are available with 75mm and 77mm thru holes.
- ※ Samchully Machinery Co., Ltd. is no longer an OEM manufacturer for Kitagawa® Iron Works Co., Ltd.

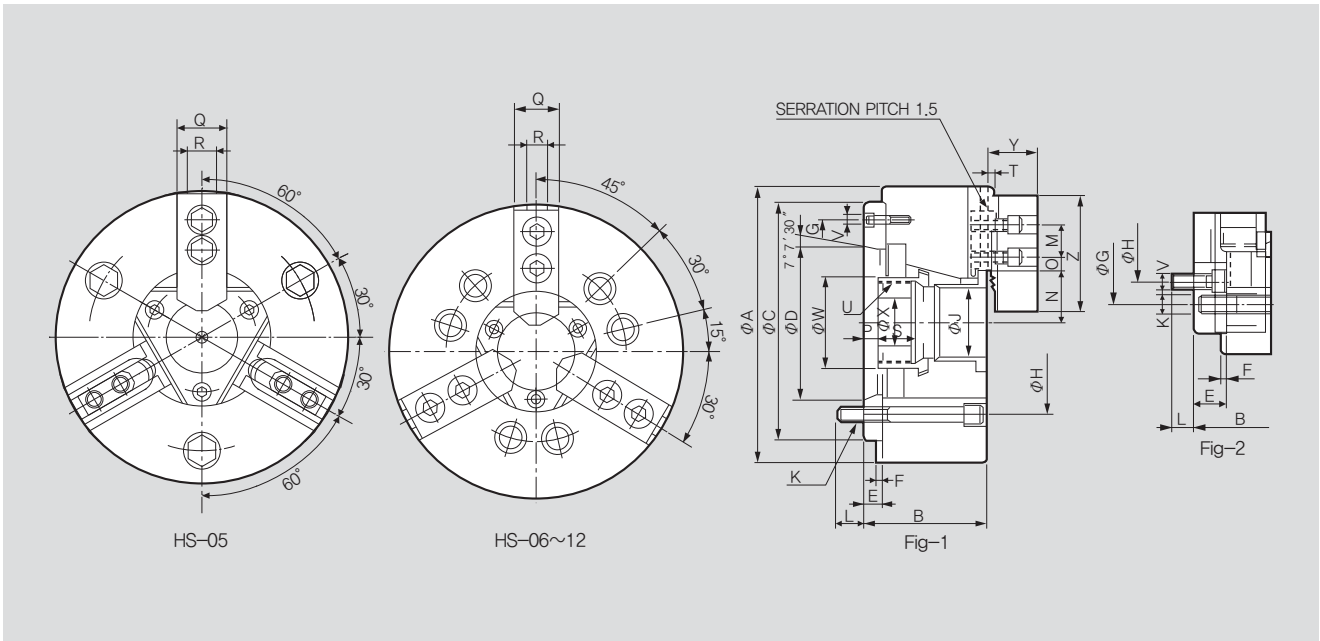

※ It is recommended to grease chucks at least twice a day in order to maximize longevity.

DIMENSIONS

	HS-05A05	HS-06A05	HS-08A06
ΦA	135	169	210
B	72	91	103
ΦC(H6)	110	140	170
ΦD	82.56	82.563	106.375
E	16	15	17
F	4	5	5
ΦG	104.8	104.8	133.4
ΦH	104.8	104.8	133.4
ΦJ	33	46	52
K	3-M10x75	6-M10x95	6-M12x105
L	14	16	18
M	14	20	25
N max.	26.5	32	38.7
N min.	23.8	29.25	35
O max.	19.75	22.75	29.75
O min.	7.75	9.25	14.75
P max.	17	26	31.5
P min.	7	14	15.5
Q	23	31	35
R	10	12	14
S	20	19	20.5
T	2	2	2
U max.	M40x1.5	M55x2	M60x2
V	3xM6	3xM6	6xM6
ΦW	47	60	66
ΦX	-	20	30
Y	26	29	39
Z	54	72	95

※ Blank and machined draw-nuts are available.
※ Refer to Fig-2 for HS-10A06, HS-12A06.

RELATED PRODUCT

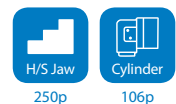

HS-A 3-Jaw High-Speed Open Center Chuck with Adaptor (254mm - 304mm)



Application / Benefits

For work requiring a through hole

Technical features

Wedge hook style chuck with high gripping force

ACTUAL GRIPPING FORCE DIAGRAM

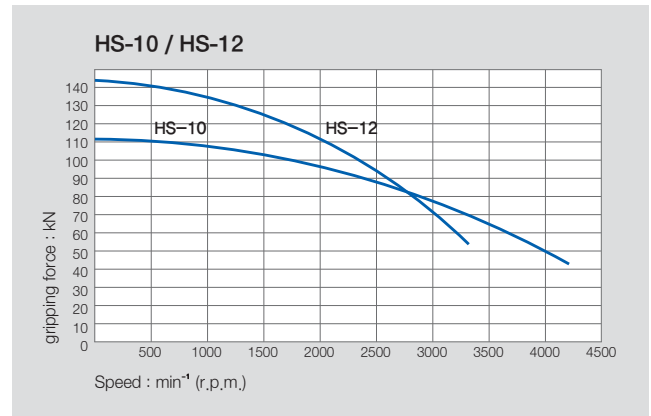
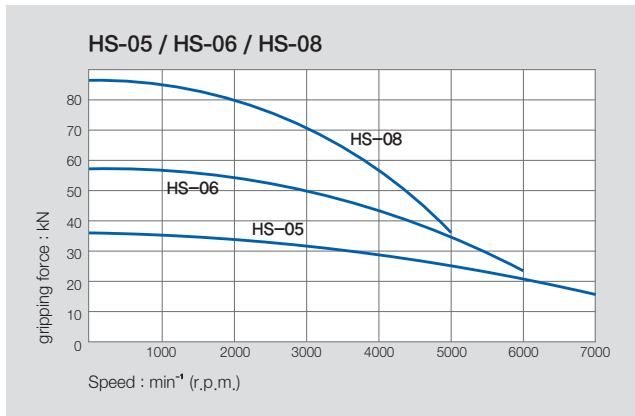

SPECIFICATIONS

	HS-10A06	HS-10A08	HS-12A06	HS-12A08
Spindle Nose	A2-6	A2-8	A2-6	A2-8
Thru Hole Dia. [mm]	77	77	91	91
Grip Dia. Max [mm]	254	254	304	304
Grip Dia. Min [mm]	31	34	42	50
Jaw Stroke Dia. [mm]	8.8	8.8	10.6	10.6
Plunger Stroke [mm]	19	19	23	23
Max. Permissible Input Force [kN(kgf)]	43(4385)	43(4385)	55(5608)	55(5608)
Max. Static Gripping Force [kN(kgf)]	111(11319)	111(11319)	144(14684)	144(14684)
Max. r.p.m. [min ⁻¹]	4200	4200	3300	3300
Weight [kg]	41.5	40	67	64
Moment of inertia [N · m ² (kg · m ²)]	12.75(1.3)	12.65(1.29)	30.6(3.12)	30.0(3.06)
Operating Cylinder	SH-18077 (SYH-1877)	SYH-18077 (SYH-1877)	SYH-2091	SYH-2091
Max. Hydraulic Pressure [MPa(kgf/cm ²)]	2.7(27.5)	2.7(27.5)	2.7(27.5)	2.7(27.5)
Operating Hard Jaw	HB10A1	HB10A1	HB12N1	HB12N1
KITAGAWA® Model	B-210A6	B-210A8	B-212A6	B-212A8

- ※ Specifications are subject to change without notice.
- ※ HS-10A06 and HS-10A08 are available with 75mm and 77mm thru holes.
- ※ Samchully Machinery Co., Ltd. is no longer an OEM manufacturer for Kitagawa® Iron Works Co., Ltd.

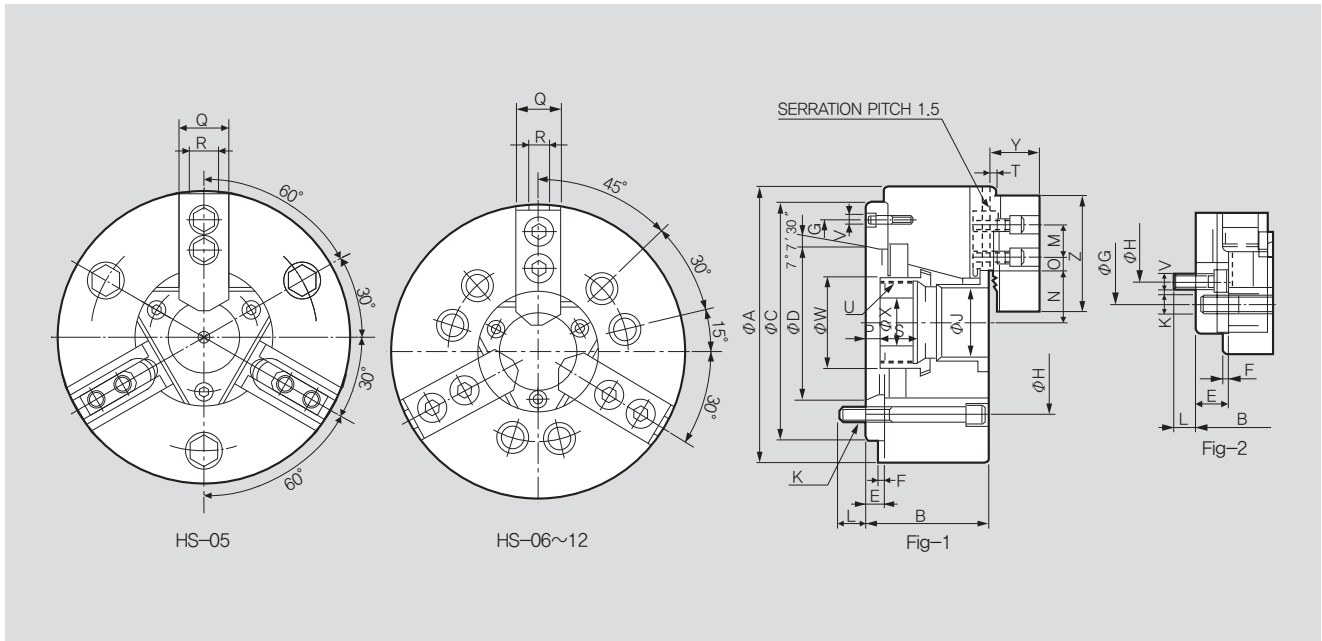

※ It is recommended to grease chucks at least twice a day in order to maximize longevity.

DIMENSIONS

	HS-10A06	HS-10A08	HS-12A06	HS-12A08
$\varnothing A$	254	254	304	304
B	120	113	129	122
$\varnothing C(H6)$	220	220	220	220
$\varnothing D$	106.375	139.719	106.375	139.719
E	25	18	25	18
F	5	5	6	6
$\varnothing G$	133.4	171.4	133.4	190
$\varnothing H$	171.4	171.4	171.4	171.4
$\varnothing J$	77	77	91	91
K	6-M16x100	6-M16x120	6-M16x110	6-M16x130
L	18.5	24	18.5	25
M	30	30	30	30
N max.	51	51	61.3	61.3
N min.	46.6	46.6	56	56
O max.	33.75	33.75	45.75	45.75
O min.	14.25	14.25	15.75	15.75
P max.	33.5	26.5	33	26
P min.	14.5	7.5	10	3
Q	40	40	49	49
R	16	16	21	21
S	25	25	28	28
T	2	2	2	2
U max.	M75x2	M85x2	M90x2	M100x2
V	6xM12	6xM8	6xM12	6xM8
$\varnothing W$	94	94	108	108
$\varnothing X$	45	45	50	50
Y	43	43	50.5	50.5
Z	110	110	111	111

※ Blank and machined draw-nuts are available.
※ Refer to Fig-2 for HS-10A06, HS-12A06.

RELATED PRODUCT

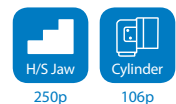

HST / HSF 2-Jaw, 4-Jaw High-Speed Open Center Chuck



Application / Benefits

For square or rectangular parts requiring a through-hole

Technical features

Wedge hook style chuck with high gripping force

ACTUAL GRIPPING FORCE DIAGRAM

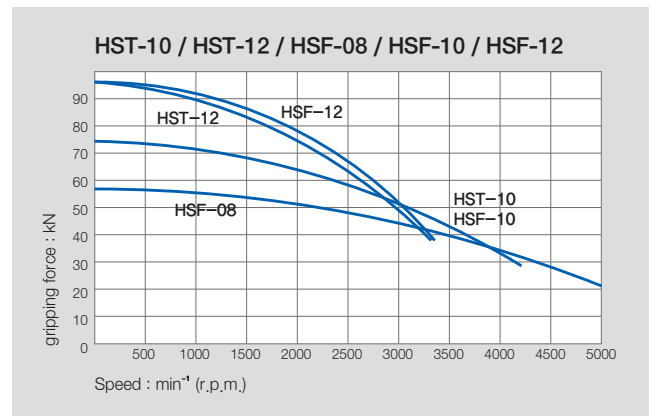
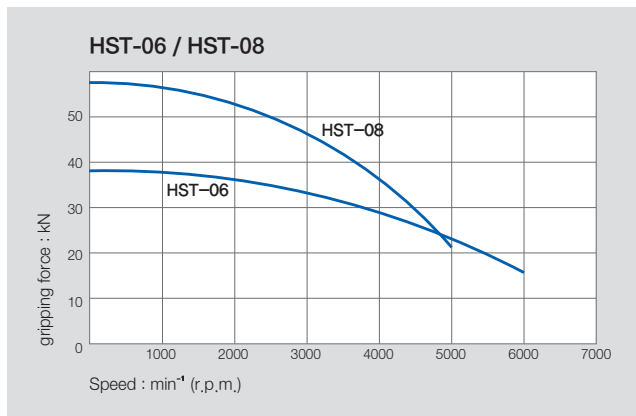

SPECIFICATIONS

	HST-06	HST-08	HST-10	HST-12	HSF-08	HSF-10	HSF-12
Thru Hole Dia. [mm]	46	52	77	91	52	77	91
Grip Dia. Max [mm]	169	210	254	304	210	254	304
Grip Dia. Min [mm]	15	13	31	34	13	31	34
Jaw Stroke Dia. [mm]	5.5	7.4	8.8	10.6	7.4	8.8	10.6
Plunger Stroke [mm]	12	16	19	23	16	19	23
Max. Permissible Input Force [kN(kgf)]	14.5 (1479)	23.2 (2366)	28.5 (2906)	36.7 (3742)	23.2 (2366)	28.5 (2906)	36.7 (3742)
Max. Static Gripping Force [kN(kgf)]	38 (3875)	57.3 (5843)	74 (7546)	96 (9789)	57.3 (5843)	74 (7546)	96 (9789)
Max. r.p.m. [min ⁻¹]	6000	5000	4200	3300	5000	4200	3300
Weight [kg]	11.5	21.3	33.5	52	22.5	34.5	52
Moment of inertia [N · m ² (kg · m ²)]	2.21 (0.225)	6.47 (0.66)	12.06 (1.23)	27.46 (2.8)	6.67 (0.68)	12.08 (1.24)	27.42 (2.8)
Operating Cylinder	SH-13046 (SYH-1246)	SH-15052 (SYH-1552)	SH-18077 (SYH-1877)	SYH-2091	SH-15052 (SYH-1552)	SH-18077 (SYH-1877)	SYH-2091
Max. Hydraulic Pressure [MPa(kgf/cm ²)]	1.85 (18.9)	1.80 (18.4)	1.80 (18.4)	1.81 (18.5)	1.80 (18.4)	1.80 (18.4)	1.80 (28.5)
KITAGAWA® Model	BT-206	BT-208	BT-210	BT-212	-	-	-

※ Maximum turning speed is based upon actual measurement.

※ Samchully Machinery Co., Ltd. is no longer an OEM manufacturer for Kitagawa® Iron Works Co., Ltd.

Thru Hole Range : $\varnothing 46 \sim \varnothing 91$
Clamping Range : $\varnothing 15 \sim \varnothing 304$

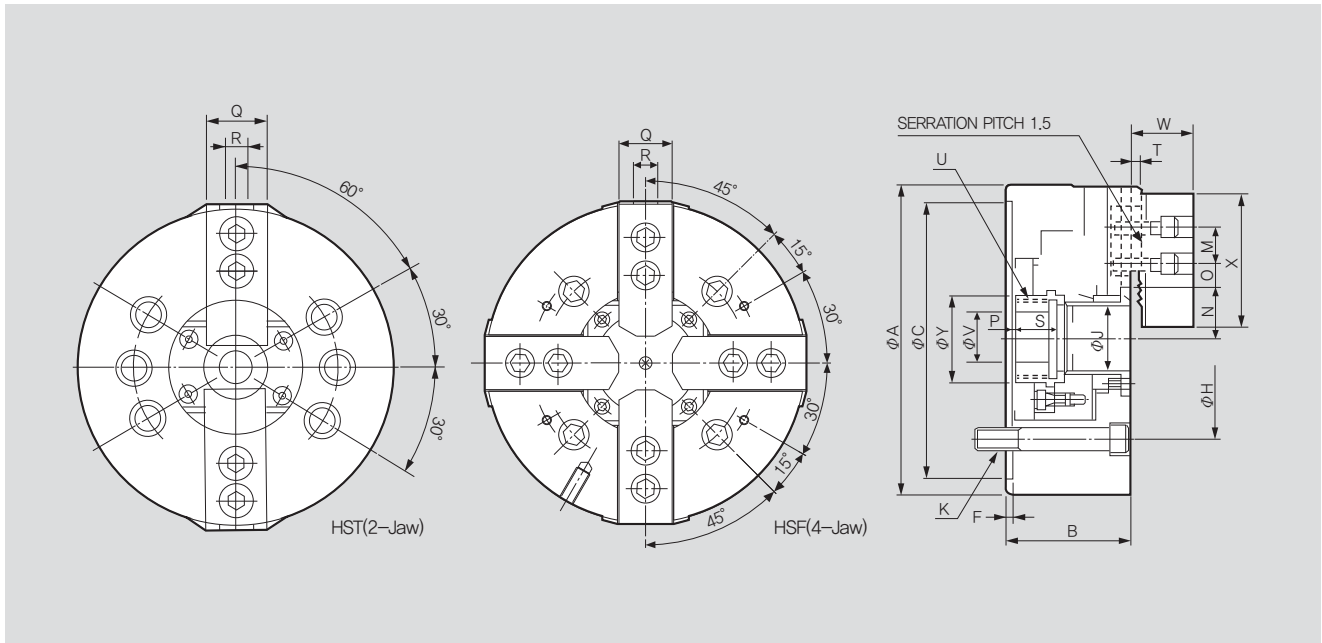

※ It is recommended to grease chucks at least twice a day in order to maximize longevity.

DIMENSIONS

	HST-06	HST-08	HST-10	HST-12	HSF-08	HSF-10	HSF-12
ΦA	169	210	254	304	210	254	304
B	81	91	100	110	91	100	110
$\Phi C(H6)$	140	170	220	220	170	220	220
F	5	5	5	6	5	5	5
ΦH	104.8	133.4	171.4	171.4	133.4	171.4	171.4
ΦJ	46	52	77	91	52	77	91
K	6-M10x95	6-M12x105	6-M16x100	6-M16x110	4-M10x105	4-M12x120	4-M16x130
M	20	25	30	30	25	30	30
N max.	32	38.7	51	61.3	38.7	51	61.3
N min.	29.25	35	46.6	56	35	46.6	56
O max.	22.75	30	34	45.75	29.75	33.75	45.75
O min.	9.25	15	14.5	15.75	14.75	14.25	15.75
P min	-1	-1.5	-10.5	-15	-1.5	-11	-15
P max	11	14.5	8.5	8	14.5	8.5	8
Q	31	35	40	49	35	40	49
R	12	14	16	21	14	16	21
S	19	20.5	25	28	20.5	25	28
Y	2	2	2	2	2	2	2
U max.	M55x2.0	M60x2.0	M85x2.0	M100x2.0	M60x2.0	M85x2.0	M100x2.0
ΦV	20	30	45	50	30	45	50
W	29	39	43	50.5	39	43	50.5
X	66	95	110	111	95	110	111
ΦY	60	66	94	108	66	94	108

※ Blank and machined draw-nuts are available.

RELATED PRODUCT

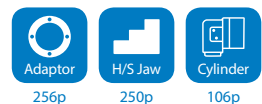

HSL 3-Jaw High-Speed Open Center Long-Stroke Chuck



Application / Benefits

For work requiring longer stroke and through-hole

Technical features

Wedge hook style chuck with high gripping force

ACTUAL GRIPPING FORCE DIAGRAM

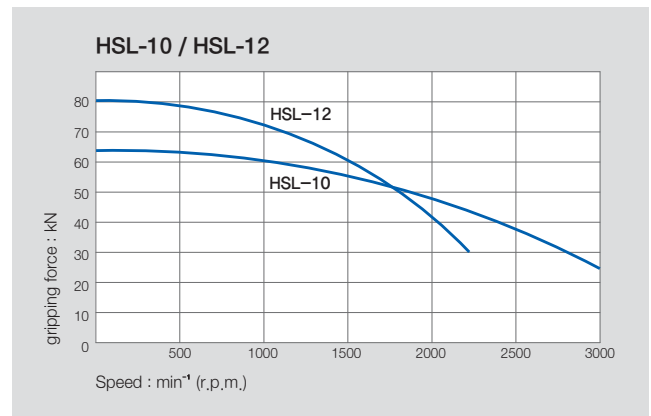
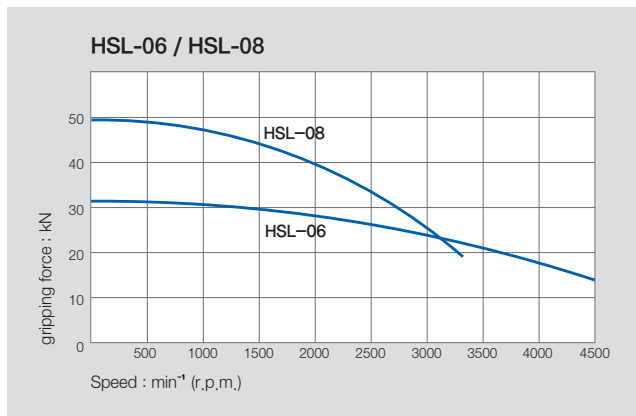

SPECIFICATIONS

	HSL-06	HSL-08	HSL-10	HSL-12
Thru Hole Dia. [mm]	33	46	53	63
Grip Dia. Max [mm]	169	215	254	304
Grip Dia. Min [mm]	28	32	42	43
Jaw Stroke Dia. [mm]	20.2	25.4	30	36
Plunger Stroke [mm]	15	22	25	30
Max. Permissible Input Force [kN(kgf)]	27.9(2845)	41.1(4191)	53.8(5486)	69.3(7067)
Max. Static Gripping Force [kN(kgf)]	31.2(3182)	49.0(4997)	63.0(6427)	80.4(8199)
Max. r.p.m. [min ⁻¹]	4500	3300	3000	2200
Weight [kg]	14	25	45	78
Moment of inertia [N · m ² (kg · m ²)]	1.67(0.17)	7.75(0.79)	12(1.2)	36(3.67)
Operating Cylinder	SH-13046 (SYH-1246)	SH-15052 (SYS-1552)	SH-18077 (SYH-1877)	SYH-2091
Max. Hydraulic Pressure [MPa(kgf/cm ²)]	3.40(34.7)	2.99(30.5)	3.20(32.6)	3.22(32.8)
Operating Hard Jaw	HB06A1	HB08A1	HB10A1	HB12N1
KITAGAWA® Model	BL-206	BL-208	BL-210	BL-212

※ Specifications are subject to change without notice.

※ Samcully Machinery Co., Ltd. is no longer an OEM manufacturer for Kitagawa® Iron Works Co., Ltd.

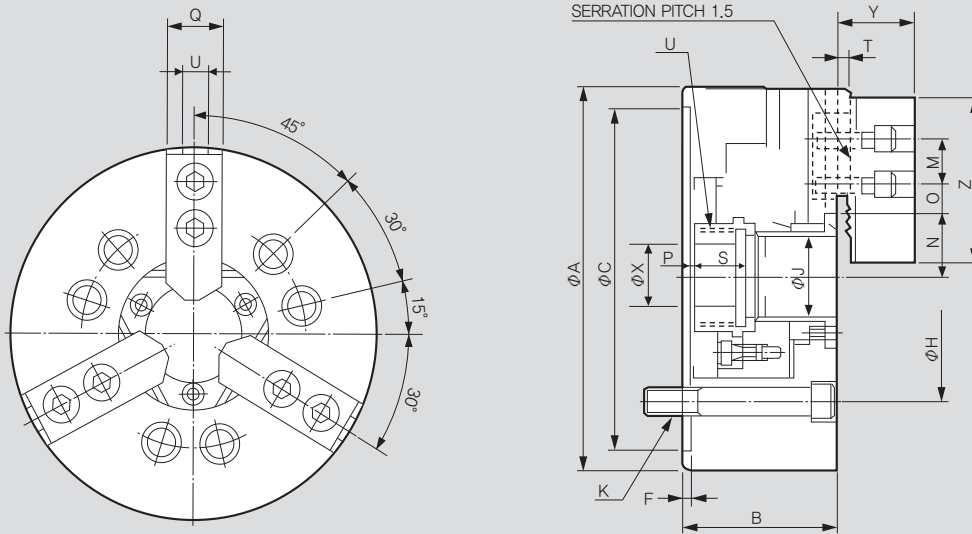

※ It is recommended to grease chucks at least twice a day in order to maximize longevity.

DIMENSIONS

	HSL-06	HSL-08	HSL-10	HSL-12
ΦA	169	215	254	304
B	84	99	110	130
ΦC(H6)	140	170	220	220
F	5	5	5	6
ΦH	104.8	133.4	171.4	171.4
ΦJ	33	46	53	63
K	6-M10	6-M10	6-M16	6-M16
M	20	25	30	30
N max.	39.3	52.3	62	72.4
N min.	29.2	39.6	46.9	54.4
O max.	16.75	20.7	26.2	38.2
O min.	9.25	11.5	9.7	8.2
P max.	14	15.5	14.5	15
P min.	-1	-6.5	-10.5	-15
Q	31	35	40	49
R	12	14	16	21
S	19	22.5	25	28
T	2	2	2	3
U max.	M42x1.5	M55x2.0	M65x2.0	M75x2.0
W	47	66	80	83
ΦX	20	30	45	50
Y	32.5	39	43	50.5
Z	72	95	110	111

※ Blank and machined draw-nuts are available.

RELATED PRODUCT

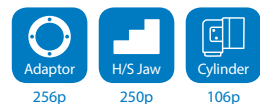

MH Mega Bore 3-Jaw High-Speed Open Center Chuck



Application / Benefits

For work requiring a large through-hole

Technical features

Wedge hook style chuck with high gripping force

ACTUAL GRIPPING FORCE DIAGRAM

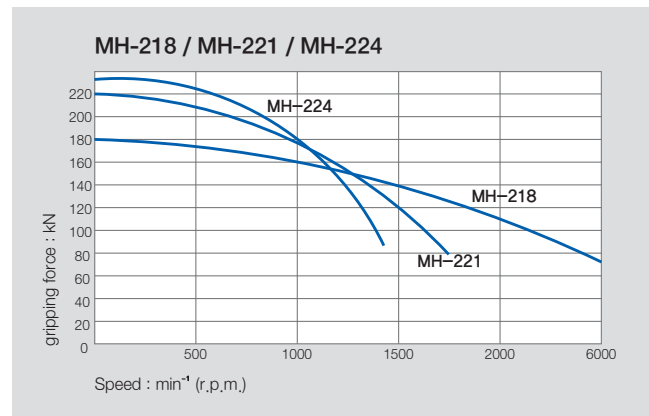
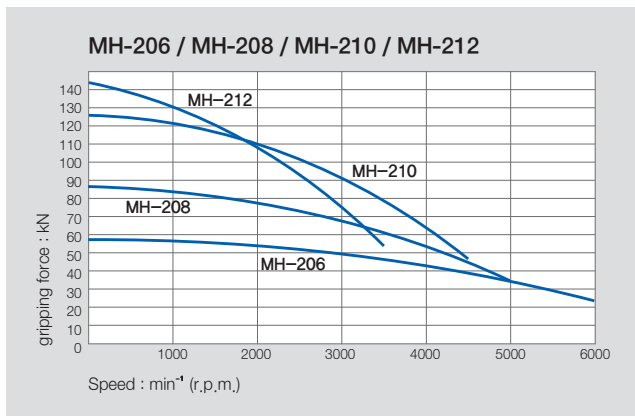

SPECIFICATIONS

	MH-206	MH-208	MH-210	MH-212	MH-218	MH-221	MH-224
Thru Hole Dia. [mm]	52	66	82	103	166.5	166.5	190
Grip Dia. Max [mm]	175	210	254	315	457	530	610
Grip Dia. Min. [mm]	16.5	23	30	54	73	105	120
Jaw Stroke Dia. [mm]	6.4	7.4	8.8	10.6	11.5	10.6	10.6
Plunger Stroke [mm]	15	17.5	19	23	25	23	23
Max. Permissible Input Force [kN(kgf)]	24.7(2551)	36.4(3596)	49(4976)	55(5608)	71(7240)	90(9177)	90(9177)
Max. Static Gripping Force [kN(kgf)]	57.3(5847)	87(8872)	126.6(12848)	144(14686)	180(18355)	220(22460)	234(23861)
Max. r.p.m. [min ⁻¹]	6000	5000	4500	3000	2000	1700	1400
Weight [kg]	11.9	23	32	55.3	170	228	293
Moment of inertia [N · m ² (kg · m ²)]	2.26(0.23)	5.6(0.57)	12.37(1.26)	28.93(2.95)	174.6(17.8)	342.1(34.7)	651(66.4)
Operating Cylinder	SH-15052 (SYH-1552)	SH-17068 (SYH-1768)	SH-19082	SH-21010	SYHL-2816	SYHL-2816	SHL-39024
Max. Hydraulic Pressure [MPa(kgf/cm ²)]	1.78(18.1)	2.34(23.9)	2.74(28)	2.65(27.2)	3.07(32)	2.86(29.1)	1.57(16.1)
Operating Hard Jaw	HB06A1	HB08A1	HB10A1	HB12N1	HB15A1	HB18B2	HB18B2

※ Specifications are subject to change without notice.

※ Samchully Machinery Co., Ltd. is no longer an OEM manufacturer for Kitagawa® Iron Works Co., Ltd.

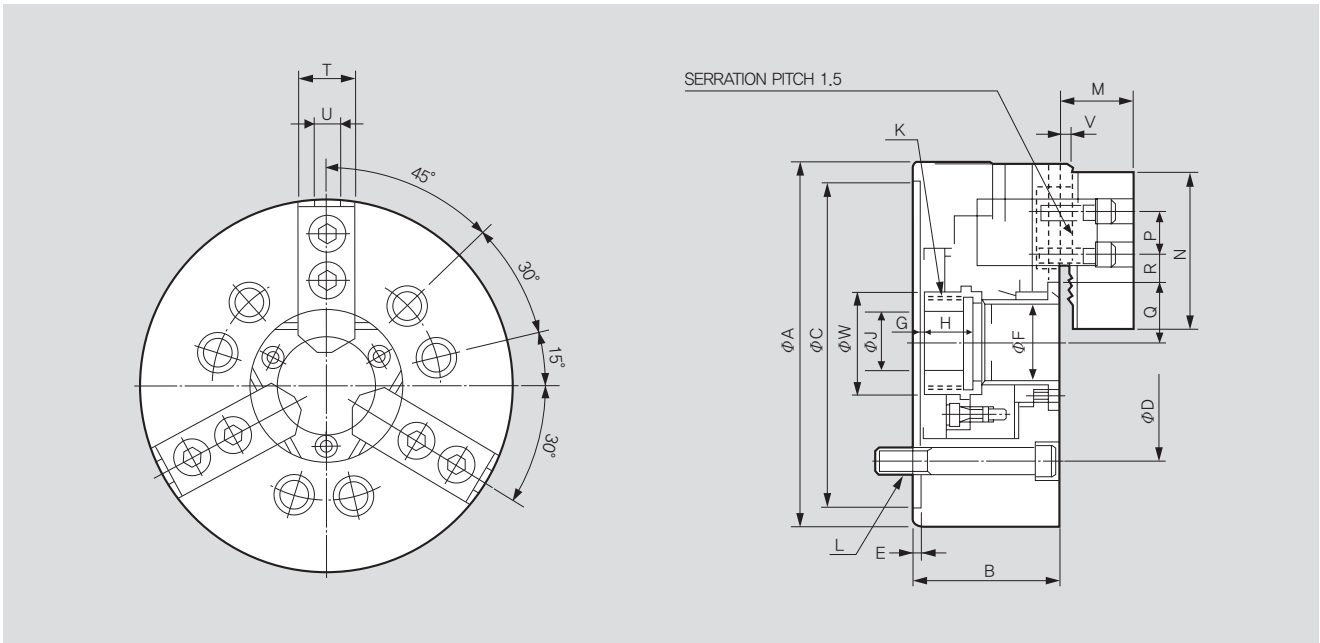

※ It is recommended to grease chucks at least twice a day in order to maximize longevity.

DIMENSIONS

	MH-206	MH-208	MH-210	MH-212	MH-218	MH-221	MH-224
ΦA	175	210	254	315	457	530	610
B	81	91	100	110	135	140	149
$\Phi C(H6)$	140	170	220	300	380	380	380
ΦD	104.8	133.4	171.4	235	300.2	330.2	330.2
E	5	5	5	6	6	6	6
ΦF	52	66	82	103	166.5	166.5	190
G max.	14	7.5	8.5	8	8	11	20
G min.	-1	-10	-10.5	-15	-23	-12	-3
H	17.5	27	25	28	50	39	40.5
ΦJ	20	30	52	82.5	107	80	80
K max.	M60x2.0	M75x2.0	M90x2.0	M116x2.0	M175x3.0	M180x3.0	M200x3.0
L	3-M10x95	6-M12x115	6-M16x120	6-M20x130	6-M20x130	6-M22x140	6-M22x150
M	33	39	43	51	69	73	73
N	72	95	110	111	165	180	180
P	20	25	30	30	50	60	60
Q max.	38	45.7	54.5	67.3	102	111.75	119.5
Q min.	34.8	42	50.1	62	96.25	106.5	114.2
R max.	21.75	23.75	32.25	45.75	58.25	72.5	105.5
R min.	10.25	11.75	14.25	15.75	20.25	21.5	21.5
T	31	35	40	49	69	65	65
U	12	14	16	21	22	25	25
V	2	2	2	2	5	5	5
ΦW	65	80	101	124	186	197	210

※ Blank and machined draw-nuts are available.

RELATED PRODUCT

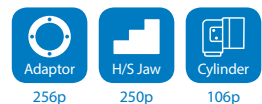

MHT / MHF

Mega Bore 2-Jaw / 4-Jaw high-Speed Open Center Chuck



Application / Benefits

For rectangular or square work requiring a large through-hole

Technical features

Wedge hook style chuck with high gripping force

ACTUAL GRIPPING FORCE DIAGRAM

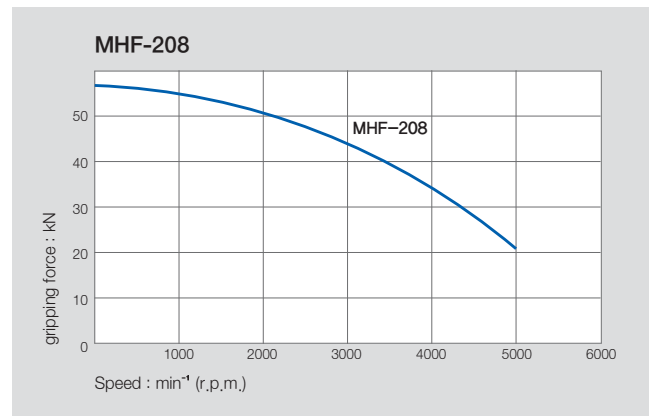
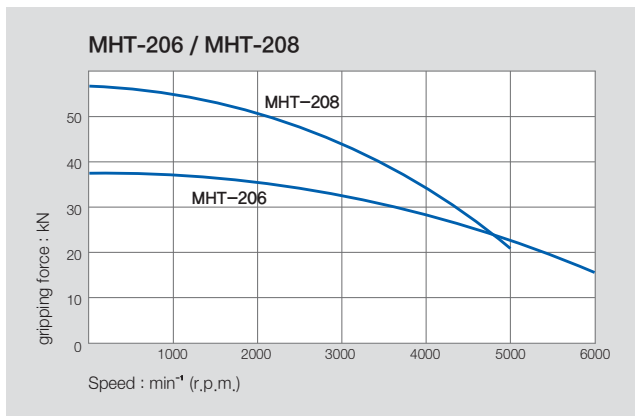

SPECIFICATIONS

	MHT-206	MHT-208	MHF-208
Thru Hole Dia. [mm]	52	66	66
Grip Dia. Max [mm]	175	210	210
Grip Dia. Min [mm]	16.5	23	23
Jaw Stroke Dia. [mm]	6.4	7.4	7.4
Plunger Stroke [mm]	15	17.5	17.5
Max. Permissible Input Force [kN(kgf)]	16.6(1700)	23.5(2397)	23.25(2397)
Max. Static Gripping Force [kN(kgf)]	38(3875)	57.9(5914)	57.9(5914)
Max. r.p.m. [min ⁻¹]	6000	5000	5000
Weight [kg]	11.5	21.7	23.5
Moment of inertia [N · m ² (kg · m ²)]	2.2(0.225)	6.47(0.66)	5.59(0.57)
Operating Cylinder	SYH-15052 (SYH-1552)	SH-17068 (SYH-1768)	SH-17068 (SYH-1768)
Max. Hydraulic Pressure [MPa(kgf/cm ²)]	1.18(12)	1.59(16.3)	1.59(163.3)
Operating Hard Jaw	HB06A1	HB06A1	HBF08A1
KITAGAWA® Model	-	-	-

※ Specifications are subject to change without notice.

※ Samcully Machinery Co., Ltd. is no longer an OEM manufacturer for Kitagawa® Iron Works Co., Ltd.

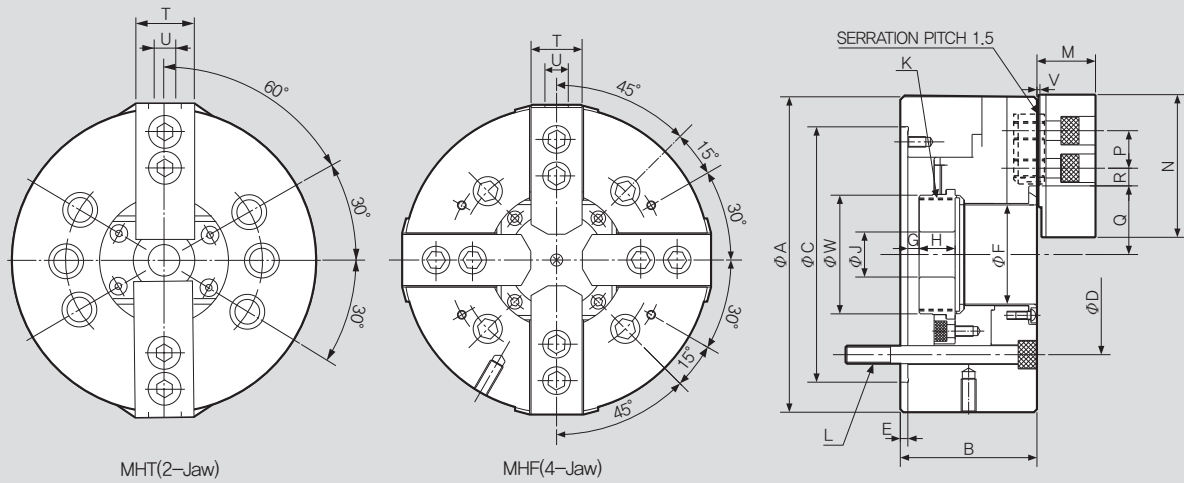

※ It is recommended to grease chucks at least twice a day in order to maximize longevity.

DIMENSIONS

	MHT-206	MHT-208	MHF-208
ΦA	175	210	210
B	81	91	91
$\Phi C(H6)$	140	170	170
ΦD	104.8	133.4	133.4
E	5	5	5
ΦF	52	66	66
G max.	14	7.5	7.5
G min.	-1	-10	-10
H	17.5	27	27
ΦJ	20	30	30
K max.	M60x2.0	M75x2.0	M75x2.0
L	6-M10x 95	6-M12x115	4-M12x115
M	32.5	39	39
N	72	95	95
P	20	25	25
Q max.	38	45.7	45.7
Q min.	34.8	42	42
R max.	21.75	23.75	23.75
R min.	10.25	11.75	11.75
T	31	35	35
U	12	14	14
V	2	2	2
ΦW	65	80	80

※ Blank and machined draw-nuts are available.

RELATED PRODUCT

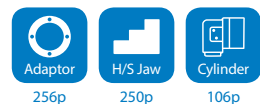

HCH 3-Jaw Open Center Chuck (110mm - 450mm)



Application / Benefits

For work requiring a through-hole

Technical features

Wedge hook style chuck with high gripping force

ACTUAL GRIPPING FORCE DIAGRAM

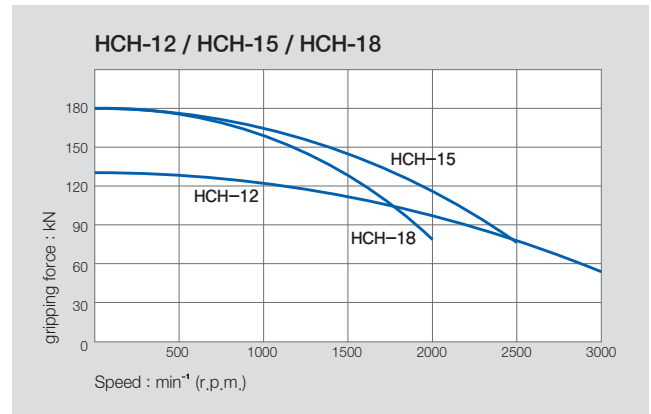
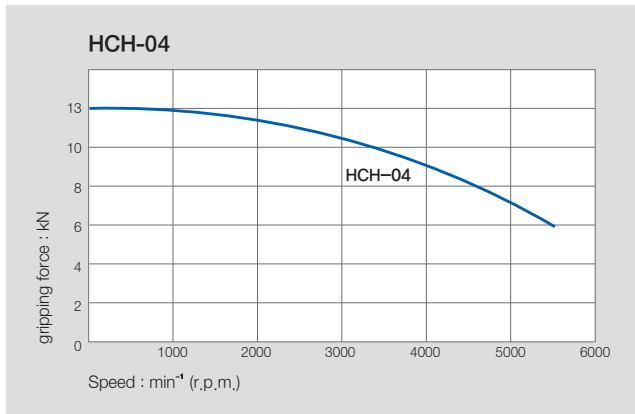

※ When using taller heavier jaw or clamping on a bigger diameter reduce draw pull rotating speed accordingly.

SPECIFICATIONS

	HCH-04	HCH-12	HCH-15	HCH-18
Thru Hole Dia. [mm]	21	78	117.5	117.5
Grip Dia. Max [mm]	110	304	381	450
Grip Dia. Min [mm]	5	19	30	30
Jaw Stroke Dia. [mm]	4.2	10.6	10.6	10.6
Plunger Stroke [mm]	6.5	23	23	23
Max. Permissible Input Force [kN(kgf)]	8(800)	49(4997)	71(7240)	71(7240)
Max. Static Gripping Force [kN(kgf)]	13(1350)	129(13150)	180(18355)	180(18355)
Max. r.p.m. [min ⁻¹]	5500	3000	2500	2000
Weight [kg]	3.7	63	120	164
Moment of inertia [N · m ² (kg · m ²)]	0.2(0.024)	29.71(3.03)	89.41(9.09)	174.6(17.8)
Operating Cylinder	HYH-0933	SH-19082	SH-25011	SH-25011
Max. Hydraulic Pressure [MPa(kgf/cm ²)]	2.2(22.4)	2.3(23.5)	2.3(23.5)	2.3(23.5)
Operating Hard Jaw	HB04A1	HB12B1	HB15A1	HB15A1
KITAGAWA® Model	B-04	B-12	B-15	B-18

※ Specifications are subject to change without notice.

※ Samchully Machinery Co., Ltd. is no longer an OEM manufacturer for Kitagawa® Iron Works Co., Ltd.

Thru Hole Range : $\varnothing 21 \sim \varnothing 117.5$
 Clamping Range : $\varnothing 5 \sim \varnothing 450$

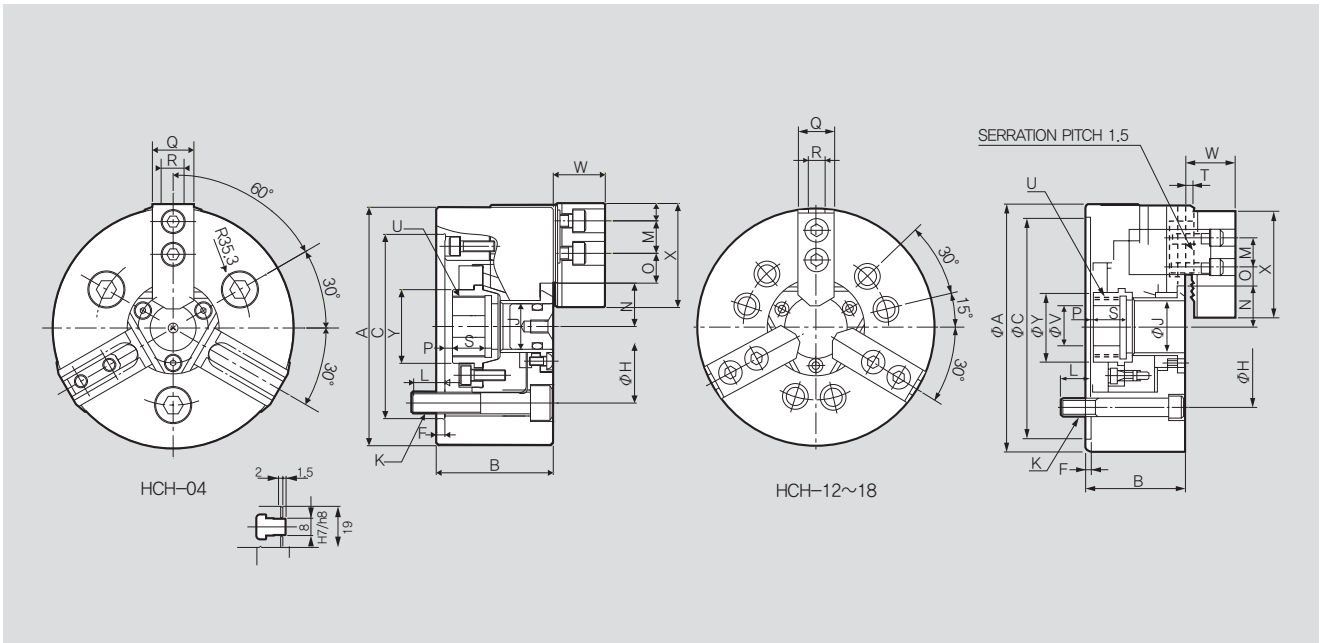

※ It is recommended to grease chucks at least twice a day in order to maximize longevity.

DIMENSIONS

	HCH-04	HCH-12	HCH-15	HCH-18
ΦA	110	304	381	450
B	54	110	133	133
$\Phi C(H6)$	85	220	300	380
F	4	6	6	6
H	70.6	171.4	235	235
ΦJ	21	78	117.5	117.5
K	3-M10	6-M16	6-M20	6-M20
L	15.5	23	50	30
M	15	30	43	43
N max.	20	58	82	82
N min.	17.9	52.7	76.7	76.7
O max.	14.25	48.75	43.75	78.25
O min.	6.75	12.75	18.25	18.25
P max.	3.5	8	11	11
P min.	-3	-15	-12	-12
Q	19	49	62	62
R	8	18	22	22
S	15	38	39	39
T	2	5	5	5
U max.	M28x1.5	M88x2.0	M130x2.0	M130x2.0
ΦV	10	50	60	60
W	24	54	70	70
X	48	129	165	165
ΦY	34	96	139	139

※ Blank and machined draw-nuts are available.

RELATED PRODUCT

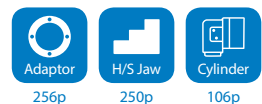

HCH 3-Jaw Open Center Chuck (530mm-800mm)



Application / Benefits

For work requiring a through-hole
Large diameter chucks offered for large work

Technical features

Wedge hook style chuck with high gripping force

ACTUAL GRIPPING FORCE DIAGRAM

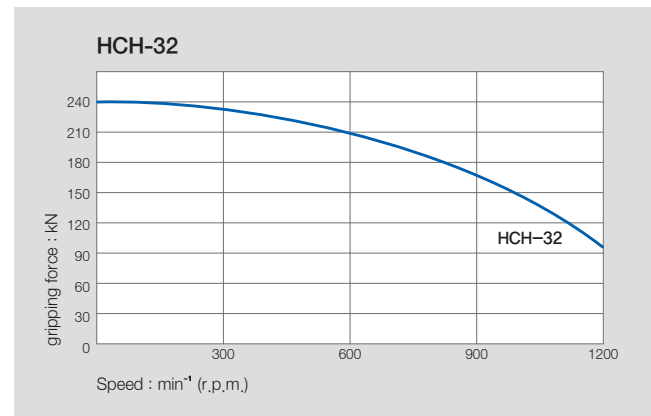
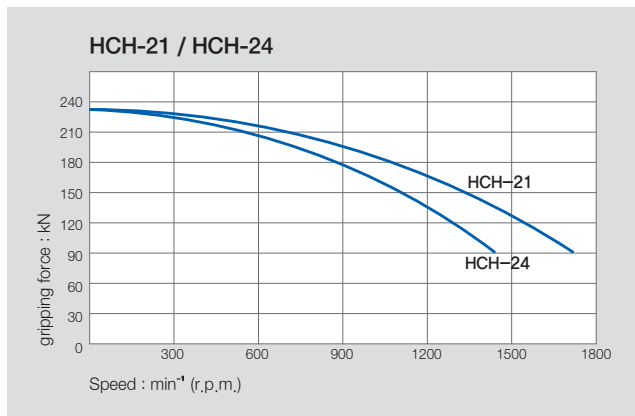

※ When using taller heavier jaw or clamping on a bigger diameter reduce draw pull rotating speed accordingly.

SPECIFICATIONS

	HCH-21	HCH-24	HCH-32
Thru Hole Dia. [mm]	140	165	240
Grip Dia. Max [mm]	530	610	800
Grip Dia. Min [mm]	87	110	240
Jaw Stroke Dia. [mm]	10.6	10.6	18
Plunger Stroke [mm]	23	23	34
Max. Permissible Input Force [kN(kgf)]	90(9177)	90(9177)	100(10193)
Max. Static Gripping Force [kN(kgf)]	234(23861)	234(23861)	240(24464)
Max. r.p.m. [min ⁻¹]	1700	1400	1200
Weight [kg]	235	293	530
Moment of inertia [N · m ² (kg · m ²)]	351.1(35.8)	651.2(66.4)	598.4(61)
Operating Cylinder	SH-25011	SYHL-2816	SYHL-2816
Max. Hydraulic Pressure [MPa(kgf/cm ²)]	3.0(30.6)	3.0(30.6)	3.2(33.6)
Operating Hard Jaw	HB18B2	HB18B2	HB32B2
KITAGAWA® Model	B-21	B-24	-

※ Specifications are subject to change without notice.

※ Samcully Machinery Co., Ltd. is no longer an OEM manufacturer for Kitagawa® Iron Works Co., Ltd.

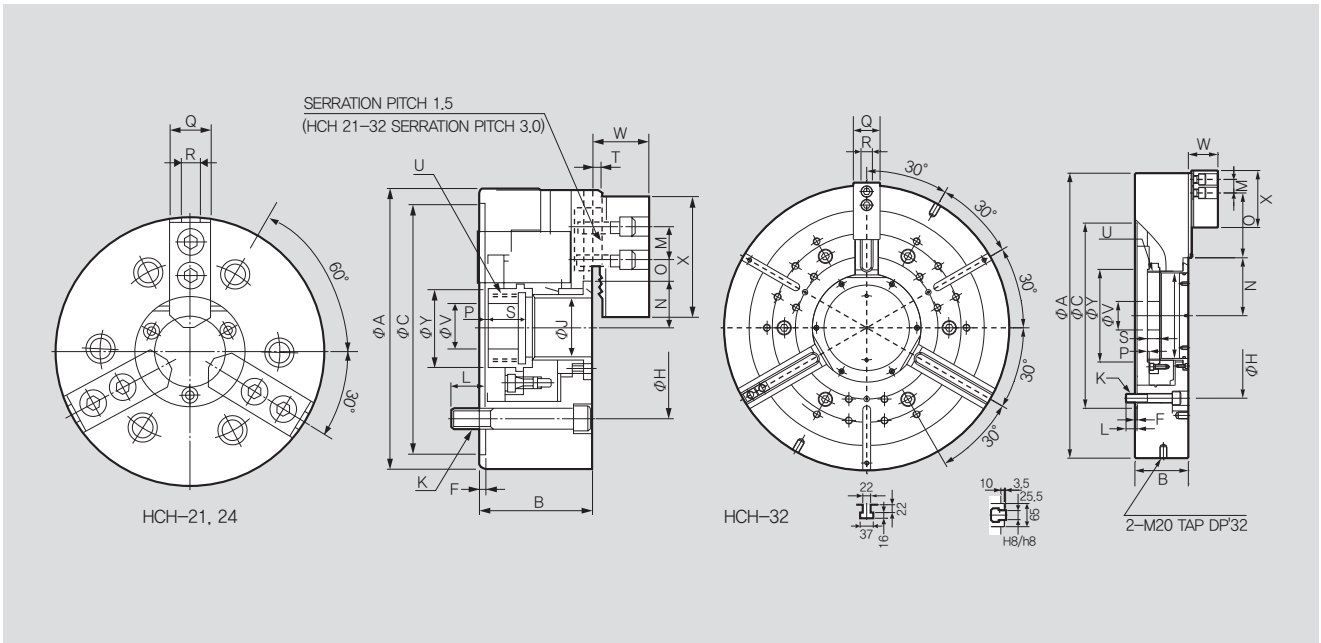

※ It is recommended to grease chucks at least twice a day in order to maximize longevity.

DIMENSIONS

	HCH-21	HCH-24	HCH-32
ΦA	530	610	800
B	140	149	150
$\Phi C(H6)$	380	380	520
F	6	6	6
H	330.2	330.2	463.6
ΦJ	140	165	240
K	6-M22	6-M22	6-M24
L	31	32	31
M	60	60	38
N max.	98.5	108	162.6
N min.	93.2	102.7	153.6
O max.	87.5	117.5	182
O min.	21.5	21.5	20
P max.	11	20	29
P min.	-12	-3	-5
Q	65	65	75
R	25	25	25.5
S	39	40	34.5
T	5	5	10
U max.	M155x3.0	M175x3.0	M250x3.0
ΦV	80	80	80
W	72	72	83
X	180	180	160
ΦY	170	187	260

※ Blank and machined draw-nuts are available.

RELATED PRODUCT



HCH-A 3-Jaw Open Center Chuck with adaptor (304mm - 381mm)



Application / Benefits

For work requiring a through-hole
Large diameter chucks offered for large work

Technical features

Wedge hook style chuck with high gripping force

ACTUAL GRIPPING FORCE DIAGRAM

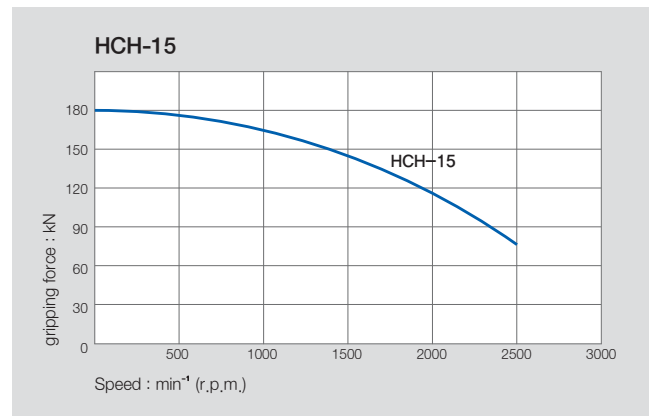
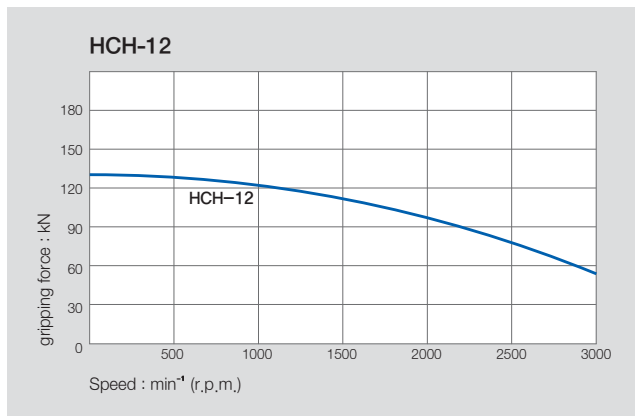

SPECIFICATIONS

	HCH-12A06	HCH-12A08	HCH-15A08	HCH-15A11
Spindle Nose	A2-6	A2-8	A2-8	A2-11
Thru Hole Dia. [mm]	78	78	117.5	117.5
Grip Dia. Max [mm]	304	304	381	381
Grip Dia. Min [mm]	19	19	30	30
Jaw Stroke Dia. [mm]	10.6	10.6	10.6	10.6
Plunger Stroke [mm]	23	23	23	23
Max. Permissible Input Force [kN(kgf)]	49(4997)	49(4997)	71(7240)	71(7240)
Max. Static Gripping Force [kN(kgf)]	129(13150)	129(13150)	180(18355)	180(18355)
Max. r.p.m. [min⁻¹]	3000	3000	2500	2500
Weight [kg]	69	66	134	127
Moment of inertia [N · m²(kg · m²)]	31.38(3.20)	30.79(3.14)	96.89(9.88)	93.55(9.54)
Operating Cylinder	SYH-2091	SYH-2091	SH-25011	SH-25011
Max. Hydraulic Pressure [MPa(kgf/cm²)]	2.3(23.5)	2.3(23.5)	2.3(23.5)	2.3(23.5)
Operating Hard Jaw	HB12B1	HB12B1	HB15A1	HB15A1
KITAGAWA® Model	B-12A6	B-12A8	B-15A8	B-15A11

※ Specifications are subject to change without notice.

※ Samcully Machinery Co., Ltd. is no longer an OEM manufacturer for Kitagawa® Iron Works Co., Ltd.

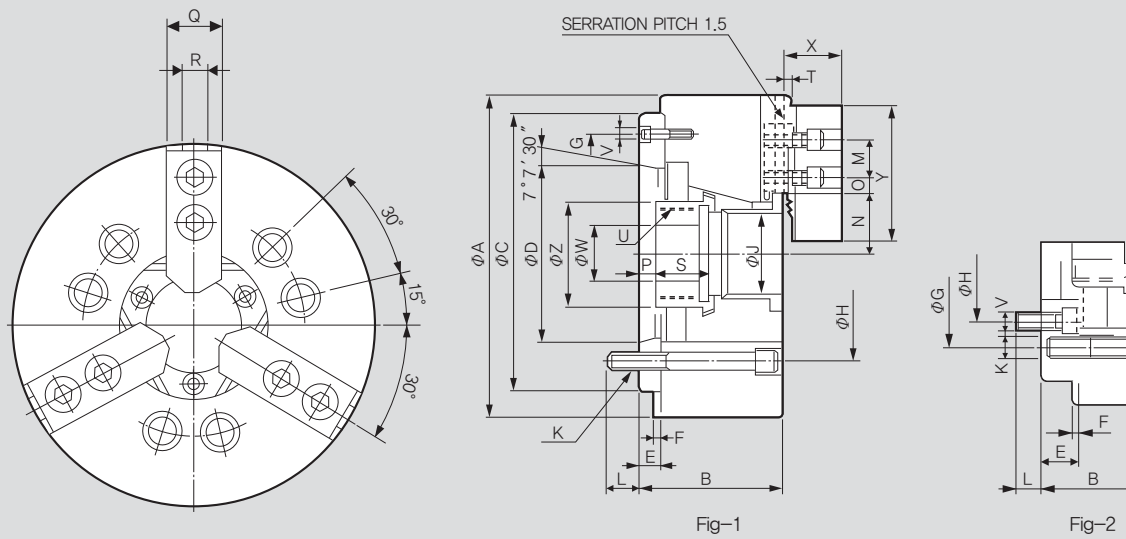

※ It is recommended to grease chucks at least twice a day in order to maximize longevity.

DIMENSIONS

	HCH-12A06	HCH-12A08	HCH-15A08	HCH-15A11
ΦA	304	304	381	381
B	129	122	160	149
ΦC(H6)	220	220	300	300
ΦD	106.375	139.719	139.719	196.869
E	25	18	33	22
F	6	6	6	6
ΦG	171.4	190	235	260
ΦH	133.4	171.4	171.4	235
ΦJ	78	78	117.5	117.5
K	6-M16x110	6-M16x130	6-M20x130	6-M20x150
L	18.5	25	24	28
M	30	30	43	43
N max.	58	58	82	82
N min.	52.7	52.7	76.7	76.7
O max.	48.75	48.75	43.75	43.75
O min.	12.75	12.75	18.25	18.25
P max.	33	26	44	33
P min.	10	3	21	10
Q	49	49	62	62
R	18	18	22	22
S	38	38	39	39
T	5	5	5	5
U max.	M88x2.0	M88x2.0	M130x2.0	M130x2.0
V	6-M12	3-M8	6-M16	3-M10
ΦW	50	50	60	60
X	53.5	53.5	70	70
Y	129	129	165	165
ΦZ	96	96	139	139

※ Blank and machined draw-nuts are available.

※ Refer to Fig-2 for HCH-12A06, HCH-12A08.

RELATED PRODUCT

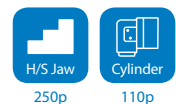

HCH-A 3-Jaw Open Center Chuck with adaptor (450mm - 610mm)



Application / Benefits

For work requiring a through-hole
Large diameter chucks offered for large work

Technical features

Wedge hook style chuck with high gripping force

ACTUAL GRIPPING FORCE DIAGRAM

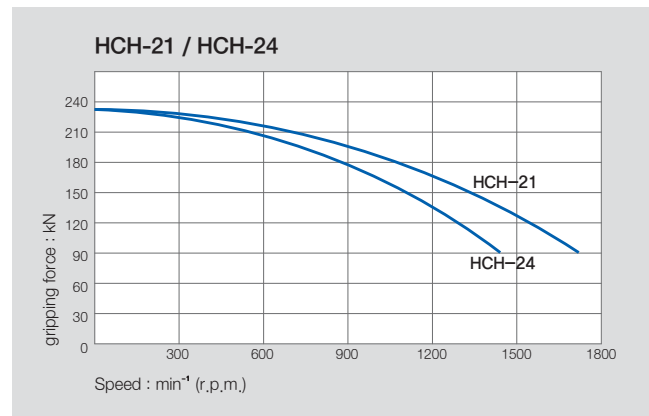
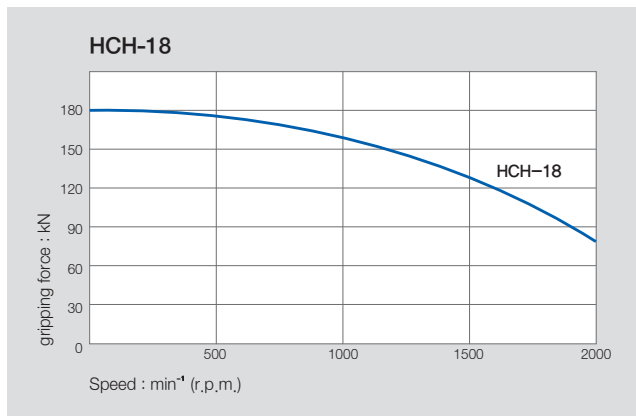

SPECIFICATIONS

	HCH-18A11	HCH-21A15	HCH-24A15
Spindle Nose	A2-11	A2-15	A2-15
Thru Hole Dia. [mm]	117.5	140	165
Grip Dia. Max [mm]	450	530	610
Grip Dia. Min [mm]	30	87	110
Jaw Stroke Dia. [mm]	10.6	10.6	10.6
Plunger Stroke [mm]	23	23	23
Max. Permissible Input Force [kN(kgf)]	71(7240)	90(91770)	90(9177)
Max. Static Gripping Force [kN(kgf)]	180(18355)	234(23861)	234(23861)
Max. r.p.m. [min⁻¹]	2000	1700	1400
Weight [kg]	178	246	304
Moment of inertia [N · m²(kg · m²)]	187.30(19.1)	362.83(37.0)	660.94(67.4)
Operating Cylinder	SH-25011	SH-25011	SYHL-2816
Max. Hydraulic Pressure [MPa(kgf/cm²)]	2.3(23.5)	3.0(30.6)	3.0(30.6)
Operating Hard Jaw	HB15A1	HB18B2	HB18B2
KITAGAWA® Model	B-18A11	B-21A15	B-24A15

※ Specifications are subject to change without notice.

※ Samcully Machinery Co., Ltd. is no longer an OEM manufacturer for Kitagawa® Iron Works Co., Ltd.

Thru Hole Range : $\varnothing 117.5 \sim \varnothing 165$
Clamping Range : $\varnothing 30 \sim \varnothing 610$

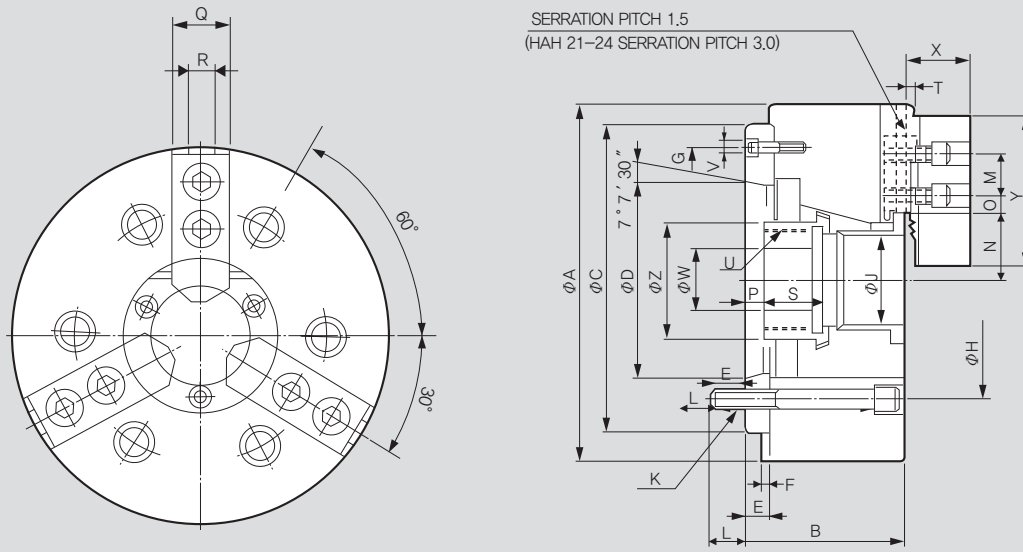

※ It is recommended to grease chucks at least twice a day in order to maximize longevity.

DIMENSIONS

	HCH-18A11	HCH-21A15	HCH-24A15
ΦA	450	530	610
B	149	161	170
$\Phi C(H6)$	380	380	380
ΦD	196.869	285.775	285.775
E	22	27	27
F	6	6	6
ΦG	320	330.2	330.2
ΦH	235	330.2	330.2
ΦJ	117.5	140	165
K	6-M20x150	6-M22x170	6-M22x180
L	28	34	35
M	43	60	60
N max.	82	98.5	108
N min.	76.7	93.2	102.7
O max.	78.28	87.5	117.5
O min.	18.25	21.5	21.5
P max.	33	38	47
P min.	10	15	24
Q	62	65	65
R	22	25	25
S	39	39	40
T	5	5	5
U max.	M130x2.0	M155x3.0	M175x3.0
V	3-M10	3-M12	3-M12
ΦW	60	80	80
X	70	72	72
Y	165	180	180
ΦZ	139	170	187

※ Blank and machined draw-nuts are available.

※ HCH-21A15 and HCH24A15 are available with M22 or M24 mounting bolts.

RELATED PRODUCT



HCHT / HCHF 2-Jaw,4-Jaw Open Center Chuck



Application / Benefits

For rectangular or square work requiring a through-hole
Large diameters offered for large work

Technical features

Gripping force transmission by wedge structure

ACTUAL GRIPPING FORCE DIAGRAM

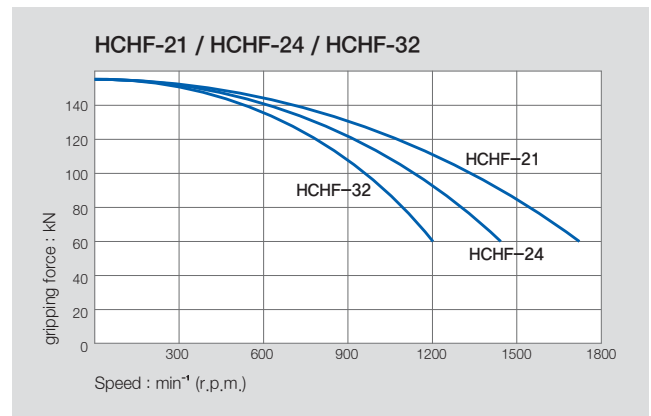
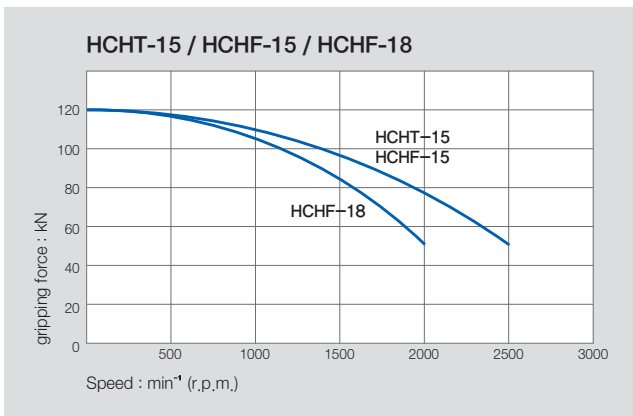

SPECIFICATIONS

	HCHT-15	HCHF-15	HCHF-18	HCHF-21	HCHF-24	HCHF-32
Thru Hole Dia. [mm]	117.5	117.5	117.5	140	166.5	240
Grip Dia. Max [mm]	381	381	450	530	610	800
Grip Dia. Min [mm]	30	30	30	87	110	160
Jaw Stroke Dia. [mm]	10.6	10.6	10.6	10.6	1.06	18
Plunger Stroke [mm]	23	23	23	23	23	34
Max. Permissible Input Force [kN(kgf)]	47(4793)	47(4793)	47(4793)	60(6117)	60(6117)	60(6795)
Max. Static Gripping Force [kN(kgf)]	120(12236)	120(12236)	120(12236)	156(15907)	156(15907)	156(15821)
Max. r.p.m. [min⁻¹]	2500	2500	2000	1700	1400	1200
Weight [kg]	115	115	159	235	293	530
Moment of inertia [N · m²(kg · m²)]	87.28(8.90)	87.3(8.90)	165.8(16.9)	351.2(35.8)	651.4(66.4)	601(61)
Operating Cylinder	SH-25011	SH-25011	SH-25011	SH-25011	SH-25011	SYHL-2816
Max. Hydraulic Pressure [MPa(kgf/cm²)]	1.5(15.3)	1.5(15.3)	1.5(15.3)	1.97(20.1)	1.97(20.1)	2.2(22.4)
Operating Hard Jaw	HB15A1	HB15A1	HB15A1	HB18B2	HB18B2	HB32B2
KITAGAWA® Model	BT-15	-	-	-	-	-

※ Specifications are subject to change without notice.

※ Samcully Machinery Co., Ltd. is no longer an OEM manufacturer for Kitagawa® Iron Works Co., Ltd.

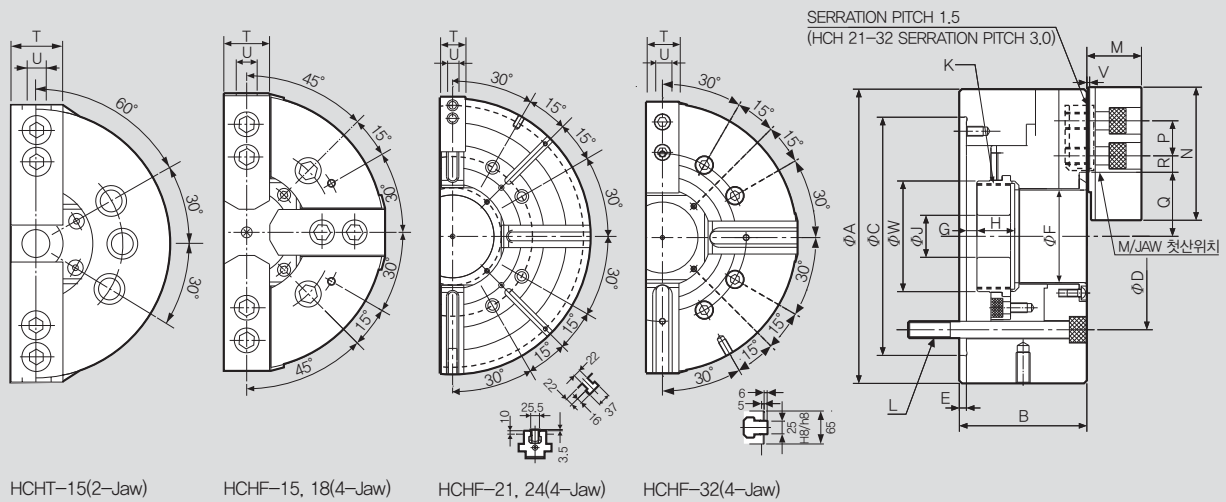

HCHT-15(2-Jaw)

HCHF-15, 18(4-Jaw)

HCHF-21, 24(4-Jaw)

HCHF-32(4-Jaw)

※ It is recommended to grease chucks at least twice a day in order to maximize longevity.

DIMENSIONS

	HCHT-15	HCHF-15	HCHF-18	HCHF-21	HCHF-24	HCHF-32
ΦA	381	381	450	530	610	800
B	133	133	133	140	149	150
ΦC(H6)	300	300	380	380	380	520
ΦD	235	235	235	330.2	330.2	463.6
E	6	6	6	6	6	6
ΦF	117.5	118	118	140	165	240
G max.	11	11	11	11	20	34
G min.	-12	-12	-12	-12	-3	0
H	39	39	39	39	40	34.5
ΦJ	60	60	60	80	80	80
K max.	M130x2.0	M130x2.0	M130x2.0	M155x3.0	M175x3.0	M250x3.0
L	6-M20x150	4-M20x150	4-M20x130	8-M22x140	8-M22x150	8-M24x130
M	70	70	70	72	72	83
N	165	165	165	180	180	160
P	43	43	43	60	60	38
Q max.	82	82	82	98.5	102.7	162.6
Q min.	76.7	76.7	76.7	93.2	108	153.6
R max.	43.75	43.75	78.25	87.5	117.5	182
R min.	18.25	18.25	18.25	21.5	21.5	20
T	62	62	62	65	65	75
U	22	22	22	25	25	25.5
V	5	5	5	5	5	3.5
ΦW	139	139	136	170	187	260

※ Blank and machined draw-nuts are available.

RELATED PRODUCT



HC 3-Jaw Closed-Center Chuck (110mm - 304mm)



Application / Benefits

Ideal for vertical lathes and work that does not require a through-hole

Technical features

Wedge hook style chuck with high gripping force

ACTUAL GRIPPING FORCE DIAGRAM

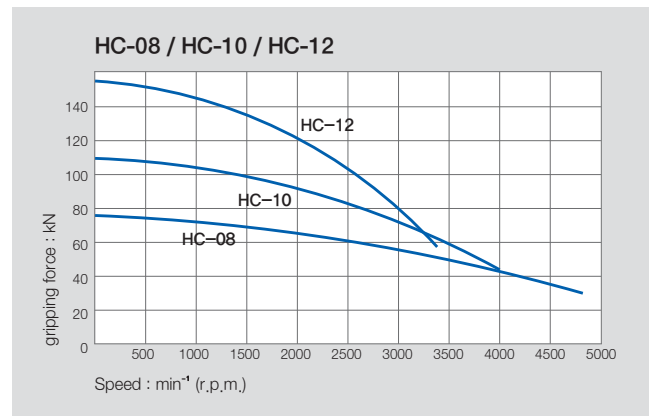
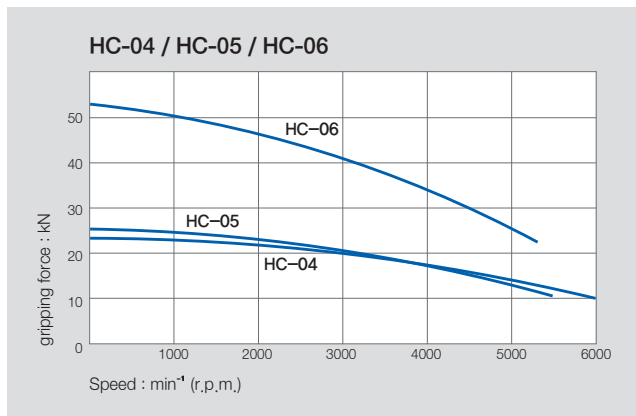

SPECIFICATIONS

	HC-04	HC-05	HC-06	HC-08	HC-10	HC-12
Jaw Stroke Dia. [mm]	6.4	6.4	8.5	8.8	8.8	10.5
Plunger Stroke [mm]	14	14	18.5	19	25	30
Grip Dia. Max [mm]	110	135	165	210	254	304
Grip Dia. Min [mm]	8	16	19	23	24	26
Max. Permissible Input Force [kN(kgf)]	8.2(836)	8.2(836)	18(1835)	25(2549)	29(2957)	41(4181)
Max. Static Gripping Force [kN(kgf)]	22.8(2325)	25.2(2570)	52.5(5353)	75(7648)	108(11013)	156(15907)
Max. r.p.m. [min ⁻¹]	6000	5500	5270	4760	4010	3380
Weight [kg]	4.1	6.2	13	25	37	57.3
Moment of inertia [N · m ² (kg · m ²)]	0.29(0.03)	0.59(0.06)	1.777(0.18)	5.39(0.55)	11.77(1.20)	28.44(2.90)
Max. Hydraulic Pressure [MPa(kgf/cm ²)]	2.4(24.5)	2.4(24.5)	2.6(26.5)	2.5(25.5)	2.8(28.6)	2.7(27.5)
Operating Cylinder Hydraulic	Y-0715R(RE)	Y-0715R(RE)	Y-1020R(RE)	Y-1225R(RE)	Y-1225R(RE)	Y-1530R(RE)
Operating Cylinder Pneumatic	AY-1315R	AY-1315R	AY-1720R	AY-2225R	AY-2225R	AY-2730R
Operating Hard Jaw	HB04N1	HB04N1	HB06A1	HB08A1	HB10A1	HB12B1
KITAGAWA® Model	N-04	N-05	N-06	N-08	N-10	N-12

※ Specifications are subject to change without notice.

※ Samchully Machinery Co., Ltd. is no longer an OEM manufacturer for Kitagawa® Iron Works Co., Ltd.

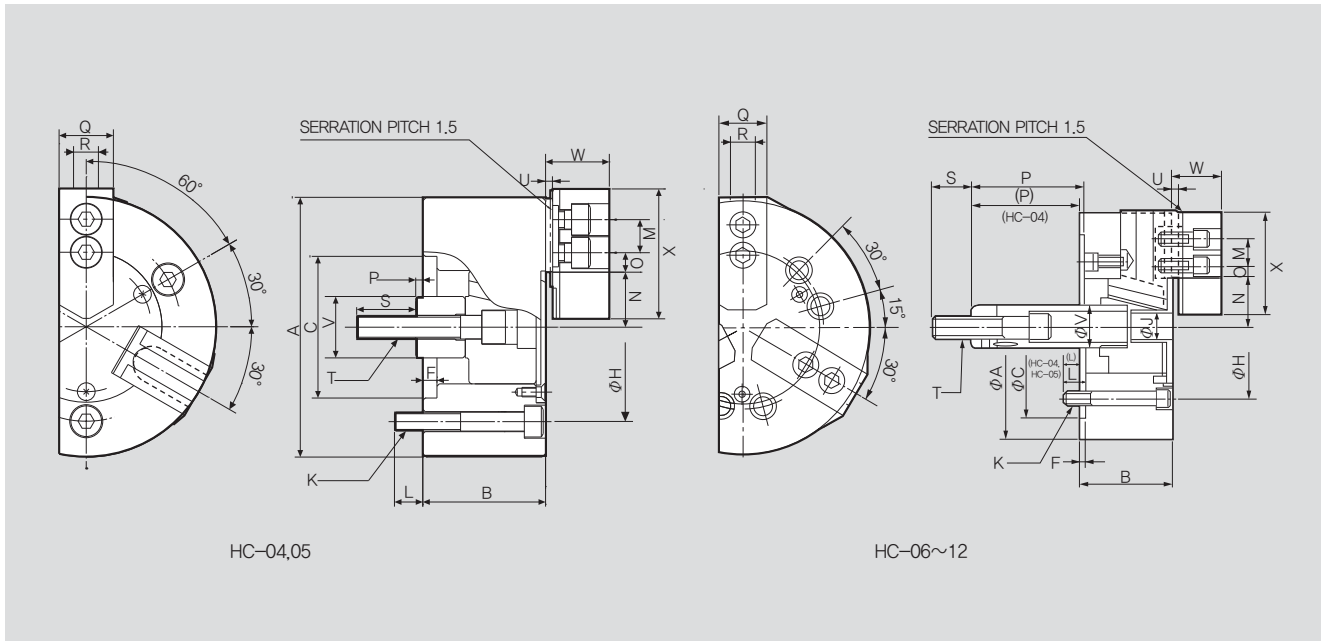

HC-04,05

HC-06~12

※ It is recommended to grease chucks at least twice a day in order to maximize longevity.

DIMENSIONS

	HC-04	HC-05	HC-06	HC-08	HC-10	HC-12
ΦA	110	135	165	210	254	304
B	52	55	74	85	89	106
$\Phi C(H6)$	60	80	140	170	220	220
F	6	7	5	5	5	6
ΦH	80	100	104.8	133.4	171.4	171.4
ΦJ	-	-	21	25	34	34
K	3-M8x55	3-M8x60	6-M10x90	6-M12x100	6-M16x105	6-M16x120
L	12	14	14	20	38	38
M	14	19	20	25	30	30
N max.	23.3	30.4	37.8	46.3	51.1	61
N min.	20.1	27.2	33.5	41.9	46.7	55.75
O max.	11.25	11.25	18	22.25	30.75	48.75
O min.	8.25	6.75	7.5	9	11.25	12.75
P max.	17	6	100	111	125	163
P min.	3	-8	81.5	92	100	133
Q	23	23	31	35	40	50
R	10	10	12	14	16	18
S	25	35	36	36	36	36
T	M10x1.5	M12x1.75	M16x2.0	M20x2.5	M20x2.5	M20x2.5
U	3	3	4	5	5	5
ΦV	26	28	34	38	45	50
W	27	29	35	42	46	54
X	55	62	72	95	110	129

RELATED PRODUCT



HC 3-Jaw Closed-Center Chuck (381mm - 1000mm)



Application / Benefits

Ideal for vertical lathes and work that does not require a through-hole
Large sizes offered for large work

Technical features

Wedge hook style chuck with high gripping force

ACTUAL GRIPPING FORCE DIAGRAM

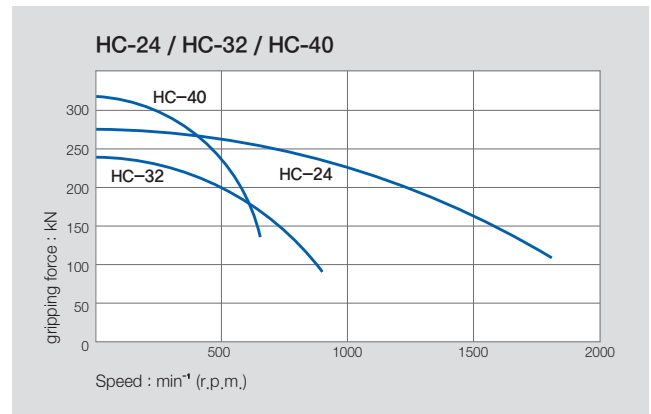
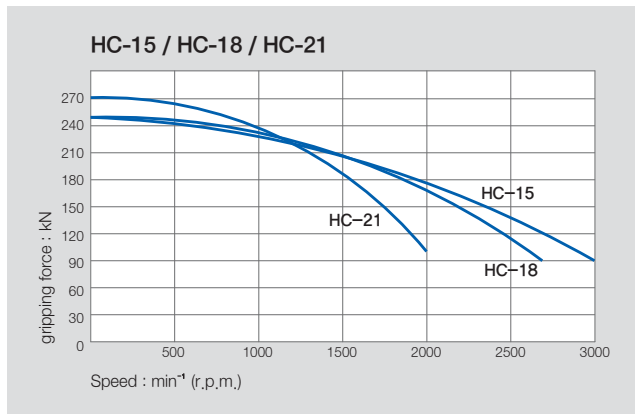

※ When using taller heavier jaw or clamping on a bigger diameter reduce draw pull rotating speed accordingly.

SPECIFICATIONS

	HC-15	HC-18	HC-21	HC-24	HC-32S	HC-40S
Jaw Stroke Dia. [mm]	16	16	16	16	30	30
Plunger Stroke [mm]	35	35	35	35	38	23
Grip Dia. Max [mm]	381	450	530	610	800	1000
Grip Dia. Min [mm]	71	133	62	152	200	330
Max. Permissible Input Force [kN(kgf)]	82(8362)	82(8362)	82(8362)	82(8362)	100(12236)	180(18256)
Max. Static Gripping Force [kN(kgf)]	249(25391)	249(25391)	273(27838)	273(27838)	240(21805)	320(32454)
Max. r.p.m. [min ⁻¹]	3040	2710	1940	1760	800	630
Weight [kg]	96	124	180	223	350	600
Moment of inertia [N · m ² (kg · m ²)]	70.61(7.2)	92.2(9.4)	188.3(19.2)	271.6(27.7)	609.1(61)	1721.8(145.6)
Max. Hydraulic Pressure [MPa(kgf/cm ²)]	3.2(32.6)	3.2(32.6)	3.2(32.6)	3.2(32.6)	3.99(40.8)	3.99(40.8)
Operating Cylinder Hydraulic	Y-2035R(RE)	Y-2035R(RE)	Y-2035R(RE)	Y-2035R(RE)	Y-2050R(RE)	Y-2560RE
Operating Hard Jaw	HB15N1	HB15N1	HB18B2	HB18B2	HB32SB2	HB40SB2
KITAGAWA® Model	N-15	N-18	N-21	N-24	-	-

※ Specifications are subject to change without notice.

※ Samchully Machinery Co., Ltd. is no longer an OEM manufacturer for Kitagawa® Iron Works Co., Ltd.

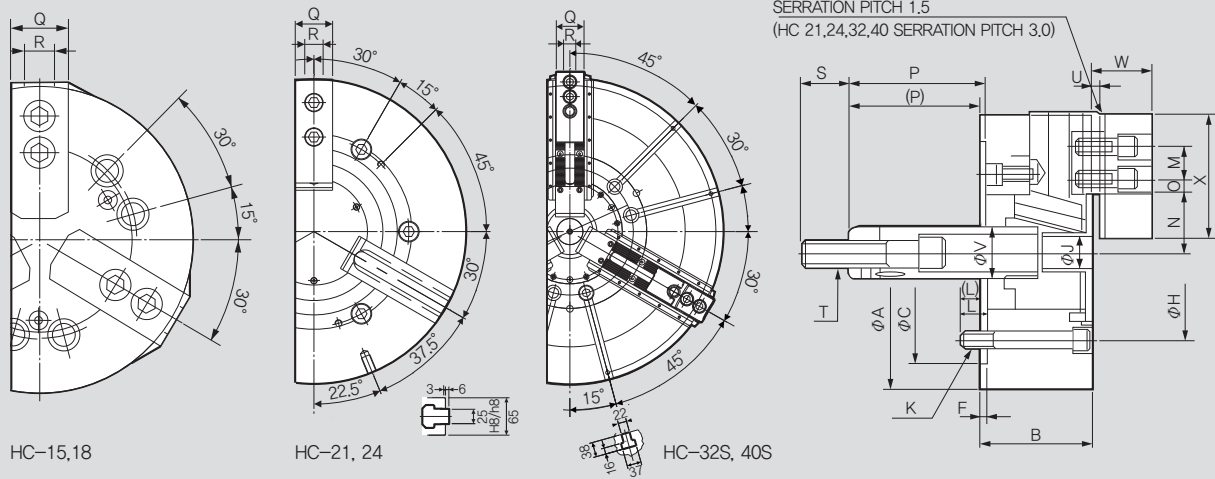

※ It is recommended to grease chucks at least twice a day in order to maximize longevity.

DIMENSIONS

	HC-15	HC-18	HC-21	HC-24	HC-32S	HC-40S
ΦA	381	450	530	610	800	1000
B	114	114	125	125	150	180
$\Phi C(H6)$	300	300	380	380	380	520
F	6	6	6	6	6	8
ΦH	235	235	330.2	330.2	330.2	463.6
ΦJ	27	27	27	27	65	50
K	6-M20X150	6-M20X115	6-M22X120	6-M22X120	6-M24X120	6-M24X120
L	65	30	31	31	39	32
M	43	43	60	60	76.2	76.2
N max.	77.5	108	86	125	117.3	212.8
N min.	69.5	100	78	117	102.3	187.8
O max.	48.75	48.75	93.5	93.5	234.1	169.8
O min.	23.25	23.25	27.5	27.5	36	17.4
P max.	104	92	97	97	38	30
P min.	69	57	62	62	0	-27
Q	62	62	65	65	75	110
R	25.5	25.5	25	25	12.7	30
S	55	55	55	55	70	65
T	M30x3.5	M30x3.5	M30x3.5	M30x3.5	M30x3.5	M36x4.0
U	2	2	3	3	8	-4
ΦV	60	60	60	60	70	70
W	61	61	70	71	81	106
X	135	135	180	180	165	270

RELATED PRODUCT

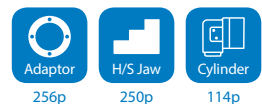

HC (Groove type jaws)

3-Jaw Hydraulic / 4-Jaw Independent Chuck
(800mm - 1600mm)



Application / Benefits

Ideal for vertical lathes and work that does not require a through-hole

Large sizes offered for large work

Manual adjustment feature allows both hydraulic and manual clamping for covering a wide range of diameters and clamping irregular work

Technical features

Wedge hook style chuck with high gripping force

ACTUAL GRIPPING FORCE DIAGRAM

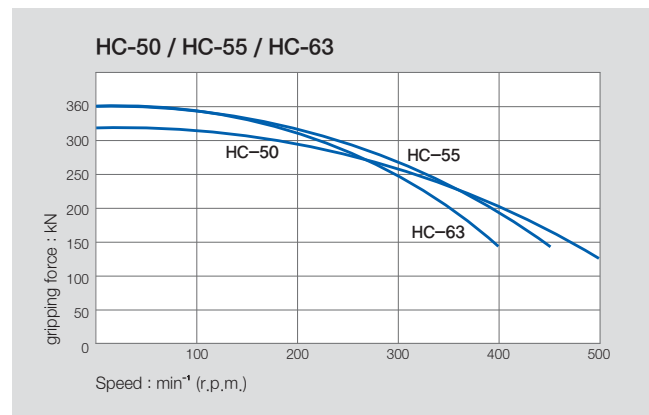
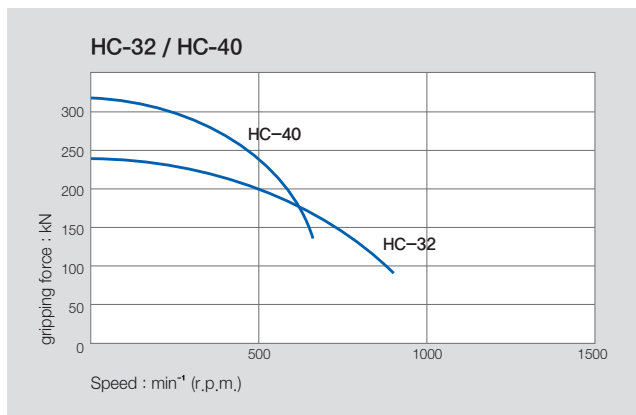

SPECIFICATIONS

	HC-32G	HC-40G	HC-50G	HC-55G	HC-63G
Jaw Stroke Dia. [mm]	30	46	46	48	48
Manual Setting	30	30	30	40	40
Plunger Stroke [mm]	38	57	57	60	60
Grip Dia. Max [mm]	800	1000	1250	1400	1600
Grip Dia. Min [mm]	200	330	330	460	460
Max. Permissible Input Force [kN(kgf)]	100 (12170)	180 (18256)	180 (18256)	200 (20394)	200 (20394)
Max. Static Gripping Force [kN(kgf)]	240 (21805)	320 (32454)	320 (32454)	360 (36710)	360 (36710)
Max. r.p.m. [min ⁻¹]	800	630	500	450	400
Weight [kg]	350	600	800	1350	1850
Moment of inertia [N · m ² (kg · m ²)]	601.9 (61)	1721.8 (174.5)	2169 (220)	2760 (280)	4930 (500)
Operating Cylinder	Y-2050RE	Y-2560RE	Y-2560RE	Y-2560RE	Y-2560RE
Max. Hydraulic Pressure [MPa(kgf/cm ²)]	3.99(40.8)	3.99(40.8)	3.99(40.8)	4.5(46)	4.5(46)
Operating Hard Jaw	HB32GB	HB40GB	HB40GB	HB40GB	HB40GB

※ Specifications are subject to change without notice.

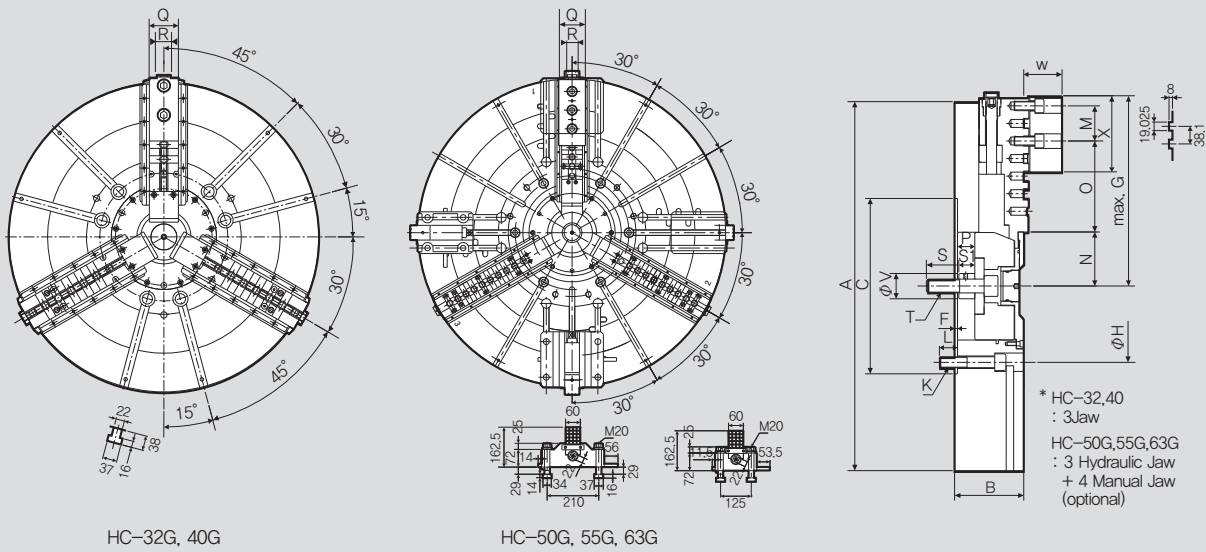

HC-32G, 40G

HC-50G, 55G, 63G

※ It is recommended to grease chucks at least twice a day in order to maximize longevity.

DIMENSIONS

	HC-32G	HC-40G	HC-50G	HC-55G	HC-63G
ΦA	800	1000	1250	1400	1600
B	150	182	180	220	220
$\Phi C(H6)$	380	520	520	720	720
F	6	8	8	8	8
G	442.5	509.6	623.9	710.6	786.8
ΦH	330.2	463.6	463.6	647.6	647.6
K	M24X120L	M24X140L	M24X140L	M24X160L	M24X160L
L	39	32	32	36	36
M	76.2	76.2	76.2	76.2	76.2
N max.	117.6	217.3	217.3	250	250
N min.	102.7	194.3	194.3	226	226
O max.	196.9	91.1	205.4	250.4	335.6
O min.	44.5	14.9	14.9	30.8	30.8
P max.	38	60	60	82	13
P min.	0	3	3	22	22
Q	75	110	110	110	110
S	70	65	65	65	65
S1	35	35	35	35	35
T	M30x3.5	M36x4.0	M36x4.0	M36x4.0	M36x4.0
ΦV	55	70	70	70	70
W	83	106	106	104	104
X	165	270	270	270	270
a1	12.7	30	30	30	30
a2	8	-4	-4	-6	-6
a3	3	4	4	4	4
a4	75	85	85	110	110

RELATED PRODUCT

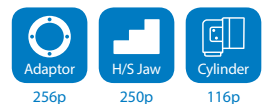

HC-A 3-Jaw Closed-Center Chuck with Adaptor (165mm - 304mm)



Application / Benefits

Ideal for vertical lathes and work that does not require a through-hole

Technical features

Wedge hook style chuck with high gripping force

ACTUAL GRIPPING FORCE DIAGRAM

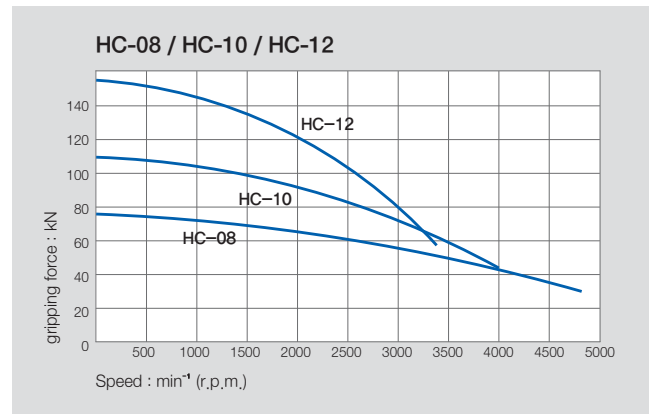
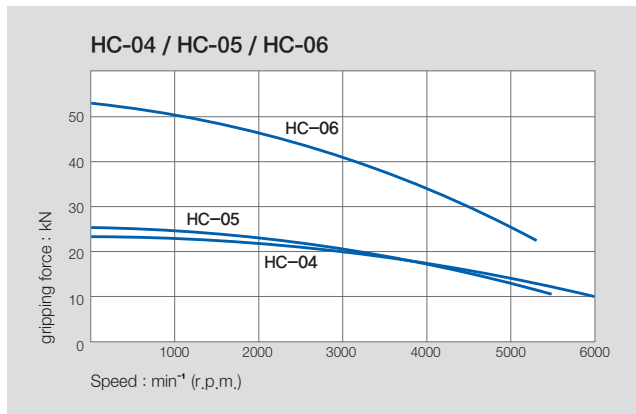

SPECIFICATIONS

	HC-06A05	HC-08A06	HC-10A06	HC-10A08	HC-12A06	HC-12A08
Spindle Nose No.	A2-5	A2-6	A2-6	A2-8	A2-6	A2-8
Jaw Stroke Dia. [mm]	8.5	8.8	8.8	8.8	10.5	10.5
Plunger Stroke [mm]	18.5	19	25	25	30	30
Grip Dia. Max [mm]	165	210	254	254	304	304
Grip Dia. Min [mm]	19	23	24	224	26	26
Max. Permissible Input Force [kN(kgf)]	18(1835)	25(2549)	29(2957)	29(2957)	41(4181)	41(4181)
Max. Static Gripping Force [kN(kgf)]	52.5(5353)	75(7648)	108(11013)	108(11013)	156(15907)	156(15907)
Max. r.p.m. [min ⁻¹]	5270	4760	4010	4010	3380	3380
Weight [kg]	14	27	40	40	67	66
Moment of inertia [N · m ² (kg · m ²)]	1.96(0.20)	5.79(0.59)	13.14(1.34)	12.84(1.31)	29.82(3.04)	29.52(3.01)
Max. Hydraulic Pressure [MPa(kgf/cm ²)]	2.6(26.5)	2.5(25.5)	2.8(28.6)	2.8(28.6)	2.7(27.5)	2.7(27.5)
Operating Cylinder Hydraulic	Y-1020R(RE)	Y-1225R(RE)	Y-1225R(RE)	Y-1225R(RE)	Y-1530R(RE)	Y-1530R(RE)
Operating Cylinder Pneumatic	AY-1720R	AY-2225R	AY-2225R	AY-2225R	AY-2730R	AY-2730R
Operating Hard Jaw	HB06A1	HB08A1	HB10A1	HB10A1	HB12A1	HB12A1
KITAGAWA® Model	N-06A05	N-08A06	N-10A06	N-10A08	N-12A06	N-12A08

※ Refer to Fig-2 for HC-10A06 and HC-12A06.

※ Specifications are subject to change without notice.

※ Samchully Machinery Co., Ltd. is no longer an OEM manufacturer for Kitagawa® Iron Works Co., Ltd.

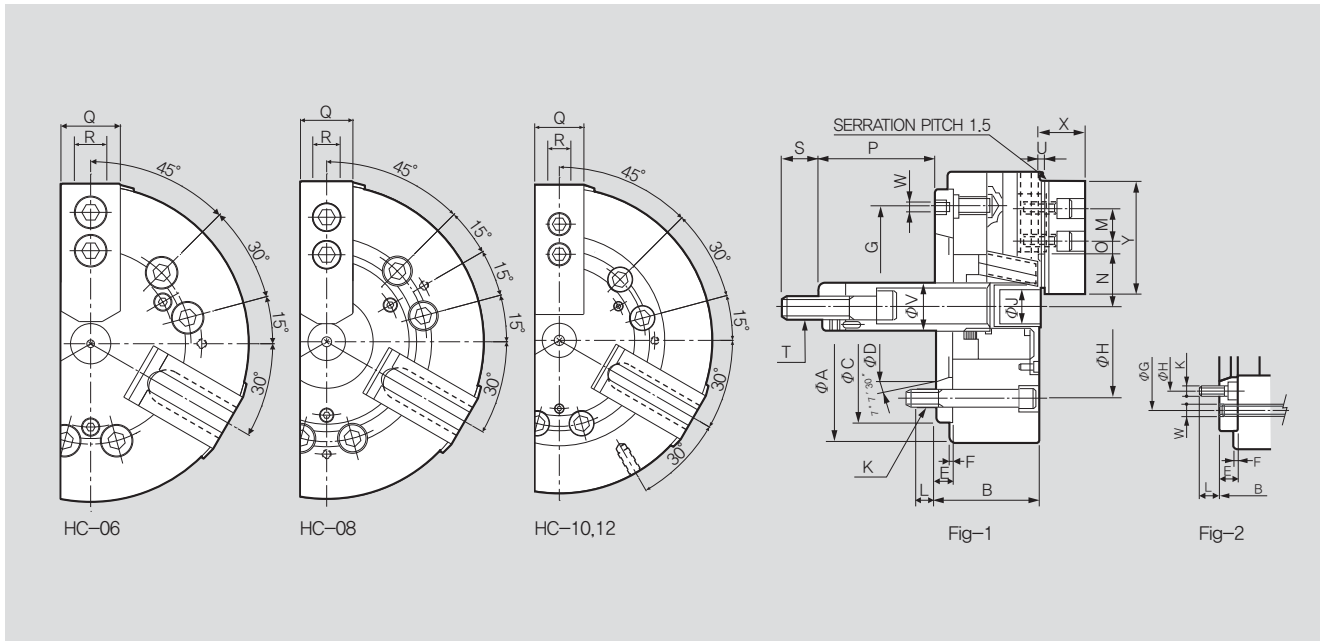

※ It is recommended to grease chucks at least twice a day in order to maximize longevity.

DIMENSIONS

	HC-06A05	HC-08A06	HC-10A06	HC-10A08	HC-12A06	HC-12A08
ΦA	165	210	254	254	304	304
B	84	97	109	102	125	118
$\Phi C(H6)$	140	170	220	220	220	220
ΦD	82.563	106.375	106.375	139.719	106.375	139.719
E	15	17	25	18	25	18
F	5	5	5	5	6	6
ΦG	116	150	171.4	190	171.4	190
ΦH	104.8	133.4	133.4	171.4	133.4	171.4
ΦJ	21	25	34	34	34	34
K	6-M10	6-M12	6-M12	6-M16	6-M12	6-M16
L	14	18	18.5	25	18	25
M	20	25	30	30	30	30
N max.	37.8	46.3	51.1	51.1	61	61
N min.	33.5	41.9	46.7	46.7	55.75	55.75
O max.	13.75	22.25	30.75	30.75	48.75	48.75
O min.	7.75	11.75	11.25	11.25	12.75	12.75
P max.	83	92(108)	84(128)	101(140)	117(138)	124(145)
P min.	64.5	73(89)	74(89)	76(115)	87(108)	94(115)
Q	31	35	40	40	49	49
R	12	14	16	16	18	18
S	358	36	36	36	36	36
T	M16x2.0	M20x2.5	M20x2.5	M20x2.5	M24x3.0 (M20x2.5)	M24x3.0 (M20x2.5)
U	4	5	5	5	5	5
ΦV	34	38	45	45	50	50
W	3-M6	3-M6	6-M16	3-M8	6-M16	3-M8
X	35	42	46	46	53.5	53.5

RELATED PRODUCT



HC-A 3-Jaw Closed-Center Chuck with Adaptor (381mm - 610mm)



Application / Benefits

Ideal for vertical lathes and work that does not require a through-hole
Large sizes offered for large work

Technical features

Wedge hook style chuck with high gripping force

ACTUAL GRIPPING FORCE DIAGRAM

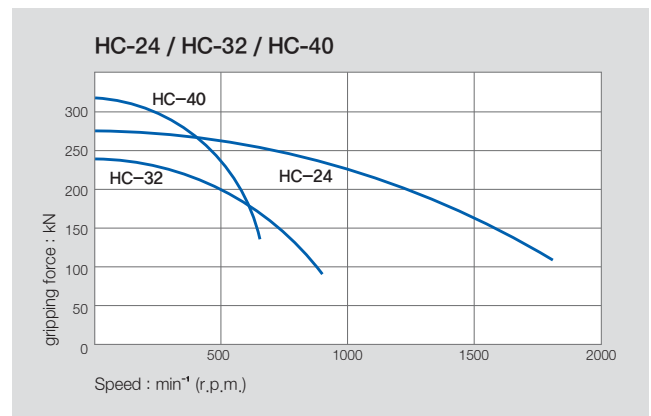
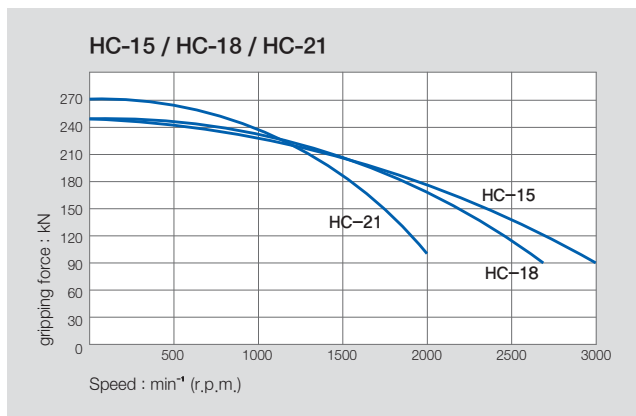

SPECIFICATIONS

	HC-15A08	HC-15A11	HC-18A08	HC-18A11	HC-21A11	HC-21A15	HC-24A11	HC-24A15
Spindle Nose No.	A2-8	A2-11	A2-8	A2-11	A2-11	A2-15	A2-11	A2-15
Jaw Stroke Dia. [mm]	16	16	16	16	16	16	16	16
Plunger Stroke [mm]	35	35	35	35	35	35	35	35
Grip Dia. Max [mm]	381	381	450	450	530	530	610	610
Grip Dia. Min [mm]	71	71	133	133	62	62	152	152
Max. Permissible Input Force [kN(kgf)]	82(8362)	82(8362)	82(8362)	82(8362)	82(8362)	82(8362)	82(8362)	82(8362)
Max. Static Gripping Force [kN(kgf)]	249(25391)	249(25391)	249(25391)	249(25391)	273(27838)	273(27838)	273(27838)	273(27838)
Max. r.p.m. [min⁻¹]	3040	3040	2710	2710	1940	1940	1760	1760
Weight [kg]	105	103	134	131	198	190	241	234
Moment of inertia [N · m²(kg · m²)]	76.49(7.8)	73.55(7.5)	97.08(9.9)	95.12(9.7)	201.03(20.5)	194.15(19.9)	289.28(29.5)	276.54(28.2)
Max. Hydraulic Pressure [MPa(kgf/cm²)]	3.2(32.6)	3.2(32.6)	3.2(32.6)	3.2(32.6)	3.2(32.6)	3.2(32.6)	3.2(32.6)	3.2(32.6)
Operating Cylinder Hydraulic	Y-2035R(RE)	Y-2035R(RE)	Y-2035R(RE)	Y-2035R(RE)	Y-2035R(RE)	Y-2035R(RE)	Y-2035R(RE)	Y-2035R(RE)
Operating Hard Jaw	HB15N1	HB15N1	HB15N1	HB15N1	HB18B2	HB18B2	HB18B2	HB18B2
KITAGAWA® Model	N-15A08	N-15A08	N-18A11	N-18A11	N-21A11	N-21A15	N-24A11	N-24A15

※ Specifications are subject to change without notice.
 ※ Refer to Fig-2 for HC-15A08, HC-18A08, HC-21A11, HC-24A11.
 ※ Samchully Machinery Co., Ltd. is no longer an OEM manufacturer for Kitagawa® Iron Works Co., Ltd.

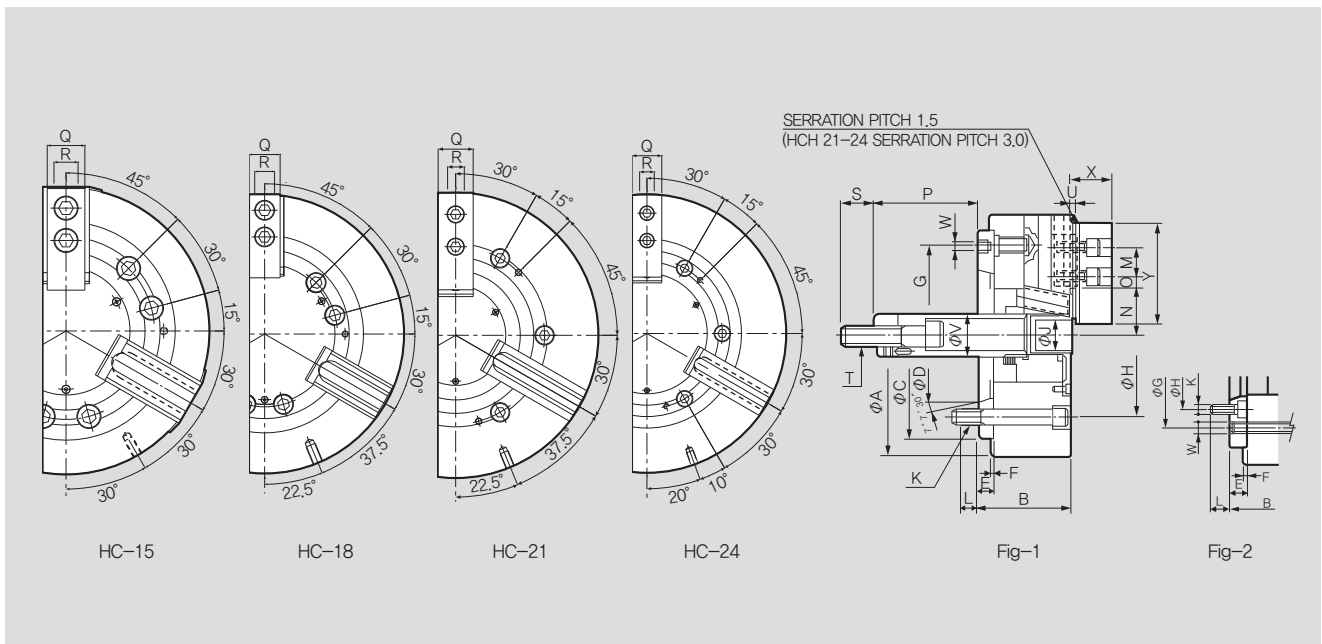

※ It is recommended to grease chucks at least twice a day in order to maximize longevity.

DIMENSIONS

	HC-15A08	HC-15A11	HC-18A08	HC-18A11	HC-21A11	HC-21A15	HC-24A11	HC-24A15
ΦA	381	381	450	450	530	530	610	610
B	141	130	141	130	161	146	161	146
$\Phi C(H_6)$	300	300	300	300	380	380	380	380
ΦD	139.719	196.869	139.719	196.869	196.869	285.775	196.869	285.775
E	33	22	33	22	42	27	42	27
F	6	6	6	6	6	6	6	6
ΦG	235	260	235	260	330.2	330.2	330.2	330.2
ΦH	171.4	235	171.4	235	235	330.2	235	330.2
ΦJ	27	27	27	27	27	27	27	27
K	6-M16	6-M20	6-M16	6-M20	6-M20	6-M22	6-M20	6-M22
L	24	33	24	33	29	34	29	34
M	43	43	43	43	60	60	60	60
N max.	77.5	77.5	108	108	86	86	125	125
N min.	69.5	69.5	100	100	78	78	117	117
O max.	48.75	48.75	48.75	48.75	93.5	93.5	93.5	93.5
O min.	23.25	23.25	23.25	23.25	27.5	27.5	27.5	27.5
P max.	71	82	59	70	55	70	55	70
P min.	36	47	24	35	20	35	20	35
Q	50	50	50	50	65	65	65	65
R	25.5	25.5	25.5	25.5	25	25	25	25
S	55	55	55	55	55	55	55	55
T	M30x3.5	M30x3.5	M30x3.5	M30x3.5	M30x3.5	M30x3.5	M30x3.5	M30x3.5
U	2	2	2	2	3	3	3	3
ΦV	60	60	60	60	60	60	60	60
W	6-M20	3-M10	6-M20	3-M10	6-M22	3-M12	6-M22	6-M12
X	61	61	61	61	70	70	70	70

RELATED PRODUCT



HCT 2-Jaw Closed-Center Chuck



Application / Benefits

Ideal for vertical lathes and square or rectangular work that does not require a through-hole

Technical features

Wedge hook style chuck with high gripping force

ACTUAL GRIPPING FORCE DIAGRAM

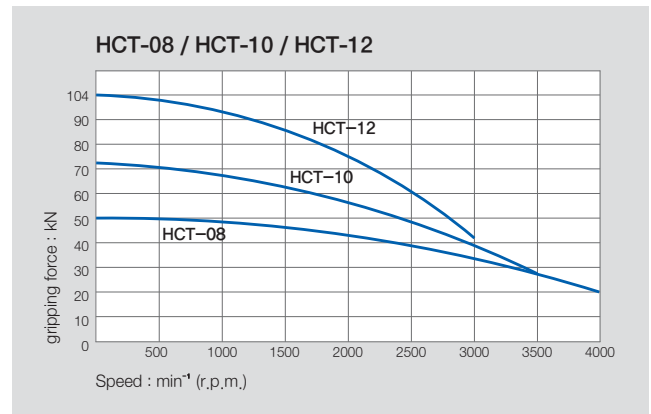
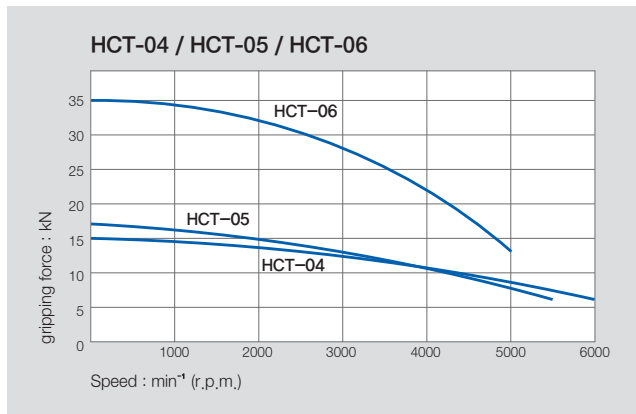

SPECIFICATIONS

	HCT-04	HCT-05	HCT-06	HCT-08	HCT-10	HCT-12
Jaw Stroke Dia. [mm]	6.4	6.4	8.5	8.8	8.8	10.5
Plunger Stroke [mm]	14	14	18.5	19	25	30
Grip Dia. Max [mm]	110	135	165	210	254	310
Grip Dia. Min [mm]	5	16	14	17	22	22
Max. Permissible Input Force [kN(kgf)]	5.3(540)	5.3(540)	12(1224)	16.5(1683)	19.5(1988)	27.5(2804)
Max. Static Gripping Force [kN(kgf)]	15.2(1550)	16.9(1713)	35(3569)	50(5099)	72(7342)	104(10605)
Max. r.p.m. [min ⁻¹]	6000	5500	5000	4000	3500	3000
Weight [kg]	3.8	5.8	11.4	22	31.6	55
Moment of inertia [N · m ² (kg · m ²)]	0.26(0.027)	0.59(0.06)	1.67(0.17)	5.20(0.53)	11.5(1.17)	27.8(2.83)
Max. Hydraulic Pressure [MPa(kgf/cm ²)]	1.68(17.1)	1.68(17.1)	1.7(17.3)	1.6(16.3)	1.9(19.4)	1.8(18.4)
Operating Cylinder	Y-0715R	Y-0715R	Y-1020R	Y-1225R	Y-1225R	Y-1530R
KITAGAWA® Model	NT-04	NT-05	NT-06	NT-08	NT-10	NT-12

※ Specifications are subject to change without notice.

※ Samchully Machinery Co., Ltd. is no longer an OEM manufacturer for Kitagawa® Iron Works Co., Ltd.

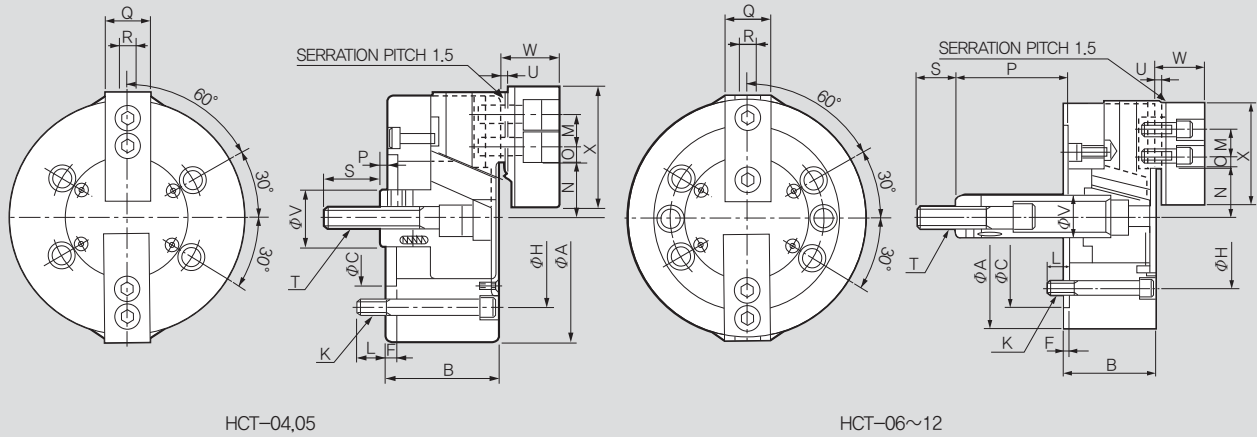

HCT-04,05

HCT-06~12

※ It is recommended to grease chucks at least twice a day in order to maximize longevity.

DIMENSIONS

	HCT-04	HCT-05	HCT-06	HCT-08	HCT-10	HCT-12
ΦA	110	135	165	210	254	304
B	52	55	74	85	89	106
$\Phi C(H6)$	60	80	140	170	220	220
F	6	7	5	5	5	6
ΦH	80	100	104.8	133.4	171.4	171.4
K	4-M8x55	4-M8x60	6-M10x70	6-M12x85	6-M16x85	6-M16x100
L	12	14	14	20	18	18
M	14	19	20	25	30	30
N max.	23.3	30.4	37.8	46.3	51.1	61
N min.	20.1	27.2	33.55	41.9	46.7	55.75
O max.	11.25	11.25	13.75	22.25	30.75	48.75
O min.	8.75	6.75	7.75	11.75	11.25	12.75
P max.	17	6	100	125	158	163
P min.	3	-8	81.5	106	133	133
Q	23	23	31	0.35	40	49
R	10	10	12	14	16	18
S	25	35	36	36	36	36
T	M10x1.5	M12x1.75	M16x2.0	M20x2.5	M20x2.5	M20x2.5
U	3	3	4	5	5	5
ΦV	26	28	34	38	45	50
W	27	29	35	42	46	53.5
X	55	62	72	95	110	129

RELATED PRODUCT



HCF 4-Jaw Closed-Center Chuck



Application / Benefits

Ideal for vertical lathes and square work that does not require a through-hole
Large sizes offered for large work

Technical features

Wedge hook style chuck with high gripping force

ACTUAL GRIPPING FORCE DIAGRAM

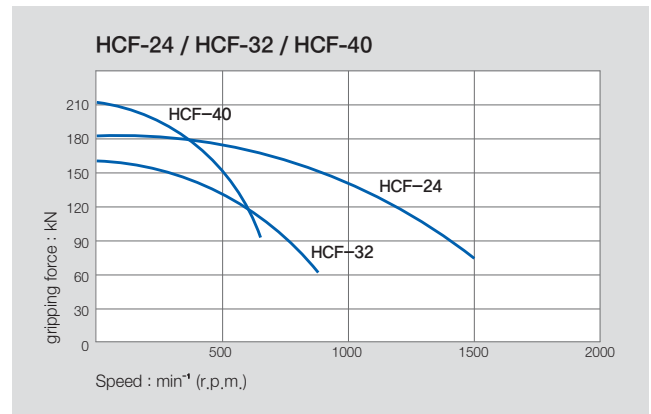
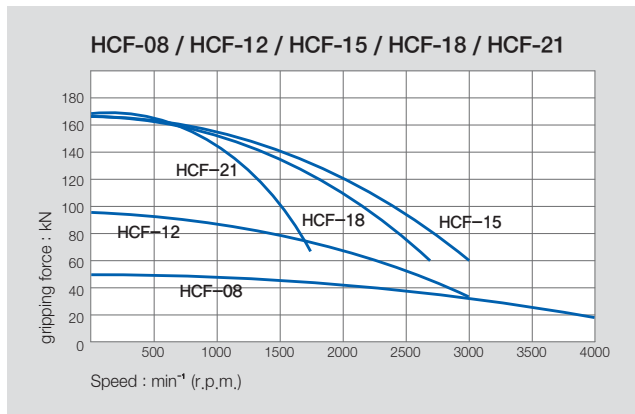

SPECIFICATIONS

	HCF-08	HCF-12	HCF-15	HCF-18	HCF-21	HCF-24	HCF-32	HCF-40
Jaw Stroke Dia. [mm]	8.8	10.5	16	16	16	16	30	46
Plunger Stroke [mm]	19	30	35	35	35	35	38	57
Grip Dia. Max [mm]	210	304	381	450	530	610	800	1000
Grip Dia. Min [mm]	17	26	71	133	62	152	85	150
Max. Permissible Input Force [kN(kgf)]	16.5(1638)	27.5(2804)	54.6(5575)	54.6(5575)	54.6(5575)	54.6(5575)	88(8925)	120(12245)
Max. Static Gripping Force [kN(kgf)]	50(5099)	104(10605)	165.8(16927)	165.8(16927)	168(18550)	183(18550)	156(15821)	213(21769)
Max. r.p.m. [min ⁻¹]	4000	3000	3040	2710	1700	1500	800	630
Weight [kg]	22	55	98	124	180	223	350	620
Moment of inertia [N · m ² (kg · m ²)]	5.20(0.53)	27.7(2.83)	72.6(7.4)	92.2(9.4)	188.3(19.2)	271.7(27.7)	601(61)	1720(174.5)
Max. Hydraulic Pressure [MPa(kgf/cm ²)]	1.6(16.3)	1.8(18.4)	2.13(21.7)	2.13(21.7)	2.13(21.7)	2.13(21.7)	3(30.6)	2.7(27.2)
Operating Cylinder	Y-1225R(RE)	Y-1530R(RE)	Y-2035R(RE)	Y-2035R(RE)	Y-2035R(RE)	Y-2035R(RE)	Y-2050RE	Y-2560RE
Operating Hard Jaw	HB08A1	HB12B1	HB15N1	HB15N1	HB18B2	HB18B2	HB32SB2	HB40SB2

※ Specifications are subject to change without notice.

※ HCF-12 is also available with long stroke.

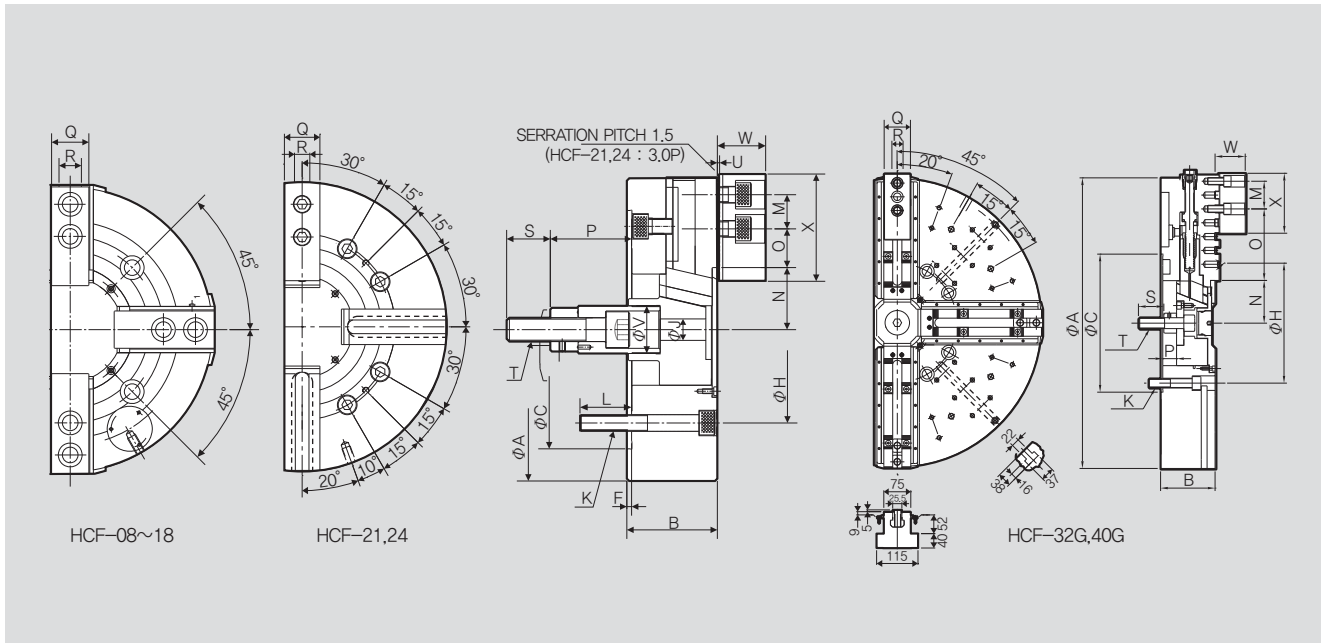

※ It is recommended to grease chucks at least twice a day in order to maximize longevity.

DIMENSIONS

	HCF-08	HCF-12	HCF-15	HCF-18	HCF-21	HCF-24	HCF-32G	HCF-40G
ΦA	210	304	381	450	530	610	800	1000
B	85	106	114	114	125	150	150	180
ΦC(H6)	170	220	300	300	380	380	380	520
F	5	6	6	6	6	6	6	8
ΦH	150	171.4	235	235	330.2	330.2	330.2	463.6
ΦJ	25	34	27	27	27	27	65	32
K	6-M12	4-M16	4-M20	4-M20	8-M22	8-M22	8-M24x120L	8-M20x160L(M24)
L	30	38	65	30	61	31	41	32
M	25	30	43	43	60	60	76.2	76.2
N max.	46.3	61	78	108	86	125	117.6	217.3
N min.	41.9	55.7	70	100	78	117	102.7	194.3
O max.	22.25	48.75	48.75	48.75	93.5	93.5	196.9	91.1
O min.	11.75	12.75	23.25	23.25	27.5	27.5	44.5	14.9
P max.	125	163	104	92	97	97	35	-25
P min.	106	133	69	57	62	62	-3	32
Q	35	49	50	50	65	65	75	110
R	14	18	26	26	25	25	25.5	30
S	36	36	55	55	55	55	70	65
T	M20x2.5	M20x2.5	M30x3.5	M30x3.5	M30x3.5	M30x3.5	M30x3.5	M36x4.0
U	5	5	2	2	3	3	5	4
ΦV	38	50	60	60	60	60	102	52
W	42	53.5	61	60	70	70	82	106
X	95	129	135	135	180	180	165	270

※ HCF-32G and HCF-40G jaws come in tongue and groove only
 ※ HCF-21 and HCF-24 are available with M22 or M24 mounting bolts.

RELATED PRODUCT

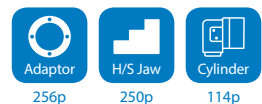

HC-SE 3-Jaw Sealed Closed-center Chuck



Application / Benefits

Ideal for vertical lathes and square or rectangular work that does not require a through-hole
 Large sizes offered for large work
 Sealed with wipers to minimize maintenance

Technical features

Wedge hook style chuck with high gripping force

ACTUAL GRIPPING FORCE DIAGRAM

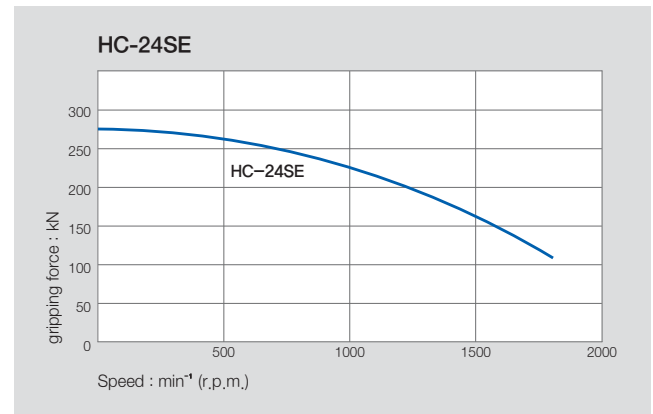
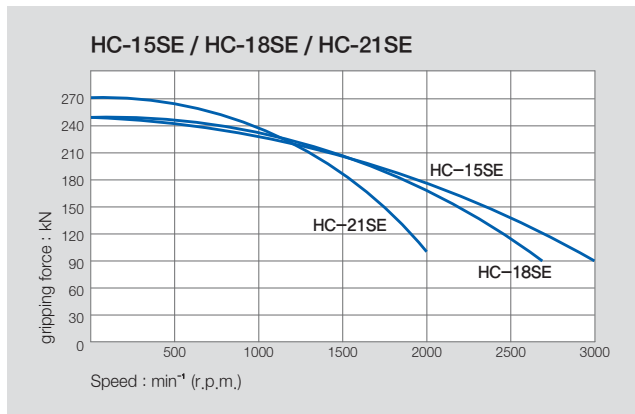

SPECIFICATIONS

	HC-15SE	HC-18SE	HC-21SE	HC-24SE
Jaw Stroke Dia. [mm]	16	16	16	16
Plunger Stroke [mm]	35	35	35	35
Grip Dia. Max [mm]	381	450	530	610
Grip Dia. Min [mm]	71	133	62	152
Max. Permissible Input Force [kN(kgf)]	82(8362)	82(8362)	82(8362)	82(8362)
Max. Static Gripping Force [kN(kgf)]	249(25391)	249(25391)	273(27838)	273(27838)
Max. r.p.m. [min ⁻¹]	3040	2710	1940	1760
Weight [kg]	96	124	180	223
Moment of inertia [N · m ² (kg · m ²)]	70.61(7.2)	92.2(9.4)	188.3(19.2)	271.6(27.7)
Max.hydraulic Pressure [MPa(kgf/cm ²)]	3.2(32.6)	3.2(32.6)	3.2(32.6)	3.2(32.6)
Operating Cylinder Hydraulic	Y-2035R(RE)	Y-2035R(RE)	Y-2035R(RE)	Y-2035R(RE)
Operating Hard Jaw	HB15N1	HB15N1	HB18B2	HB18B2
KITAGAWA® Model	N-15	N-18	N-21	N-24

※ Specifications are subject to change without notice.
 ※ HCF-12 is also available with long stroke.

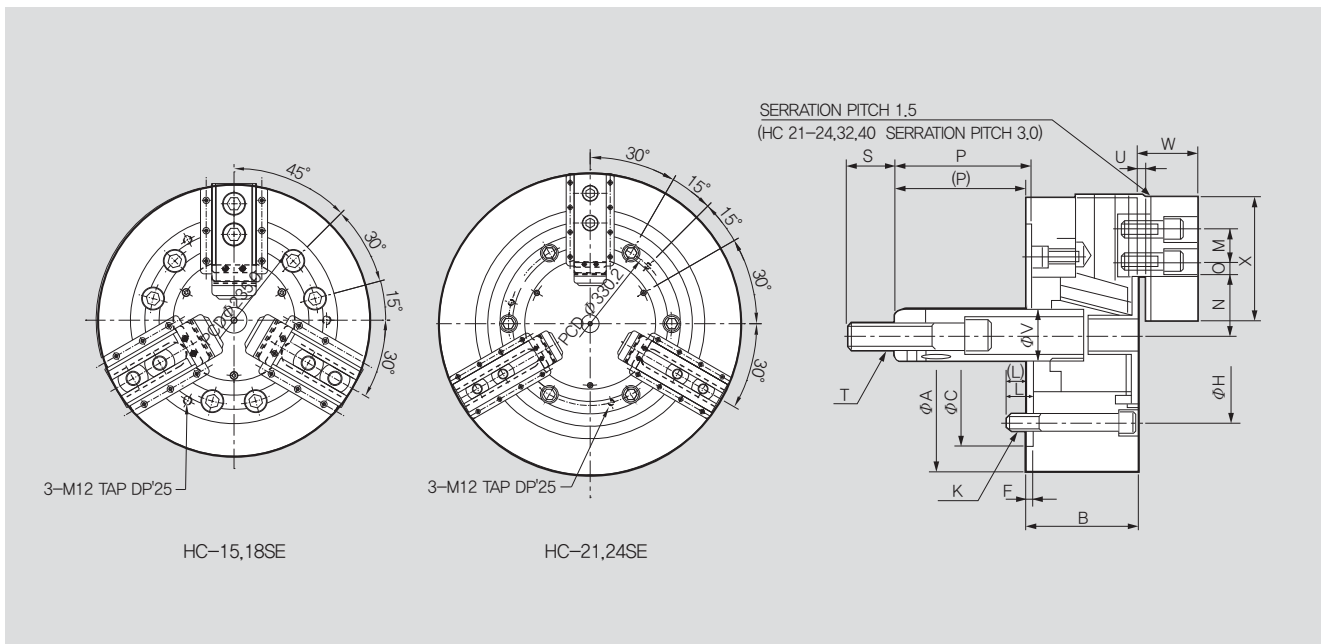

※ It is recommended to grease chucks at least twice a day in order to maximize longevity.

DIMENSIONS

	HC-15SE	HC-18SE	HC-21SE	HC-24SE
ΦA	381	450	530	610
B	114	114	125	125
$\Phi C(H6)$	300	300	380	380
F	6	6	6	6
ΦH	235.0	235.0	330.2	330.2
J	-	-	-	-
K	6-M20x150	6-M20x115	6-M22x120	6-M22x120
L	65	30	31	31
M	43	43	60	60
N max.	77.5	108	86	125
N min.	69.5	100	78	117
O max.	48.75	48.75	93.5	93.5
O min.	23.25	23.25	27.5	27.5
P max.	104	92	97	97
P min.	69	57	62	62
Q	62	62	65	65
R	25.5	25.5	25	25
S	55	55	55	55
T	M30x3.5	M30x3.5	M30x3.5	M30x3.5
U	2	2	3	3
ΦV	60	60	60	60
W	61	61	70	71
X	135	135	180	180

RELATED PRODUCT



HCL 3-Jaw Closed-Center Long-Stroke Chuck



Application / Benefits

ideal for vertical lathes and square or rectangular work that does not require a through-hole
Longer jaw stroke

Technical features

Wedge hook style chuck with high gripping force

ACTUAL GRIPPING FORCE DIAGRAM

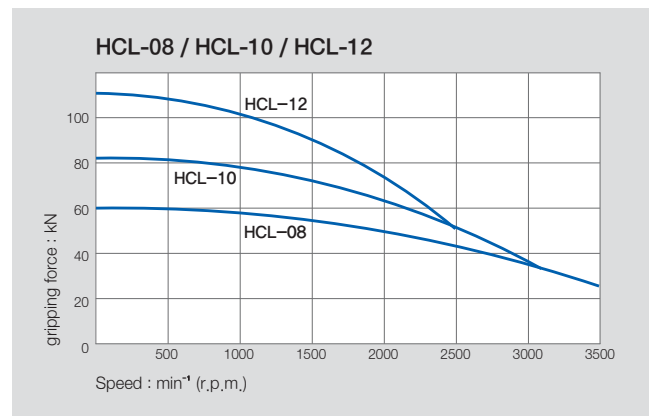
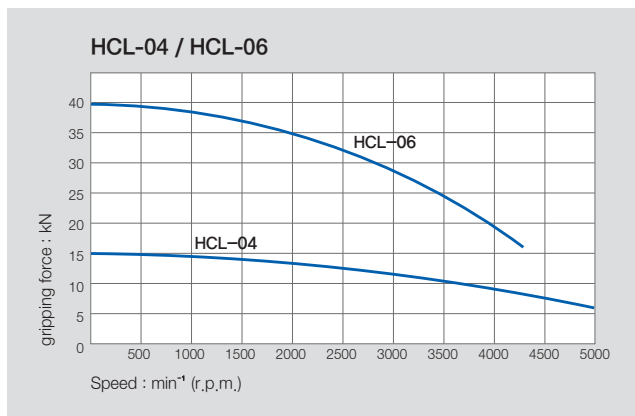

SPECIFICATIONS

	HCL-04	HCL-06	HCL-08	HCL-10	HCL-12
Jaw Stroke Dia. [mm]	12.1	13	16.2	18.1	19.4
Plunger Stroke [mm]	15	20	25	28	30
Grip Dia. Max [mm]	110	165	210	254	304
Grip Dia. Min [mm]	12	22	23	27	33
Max. Permissible Input Force [kN(kgf)]	10(1020)	21(2141)	30(3059)	40(4079)	54(5506)
Max. Static Gripping Force [kN(kgf)]	14.4(1468)	39(3977)	60(6118)	81(8260)	111(11319)
Max. r.p.m. [min ⁻¹]	5000	4300	3600	3100	2500
Weight [kg]	4.1	12	22.9	34.6	60
Moment of inertia [N · m ² (kg · m ²)]	0.29(0.03)	1.76(0.18)	5.39(0.55)	11.8(1.20)	28.4(2.90)
Max.hydraulic Pressure [MPa(kgf/cm ²)]	2.9(29.6)	3.0(29.6)	2.9(29.6)	2.8(28.6)	3.6(36.7)
Operating Cylinder	Y-0715R(RE)	Y-1020R(RE)	Y-1225R(RE)	Y-1530R(RE)	Y-1530R(RE)
Operating Hard Jaw	HB04N1	HB06A1	HB08A1	HB10A1	HB12B1
KITAGAWA® Model	NL-04	NT-06	NT-08	NT-10	NT-12

※ Specifications are subject to change without notice.

※ Samchully Machinery Co., Ltd. is no longer an OEM manufacturer for Kitagawa® Iron Works Co., Ltd.

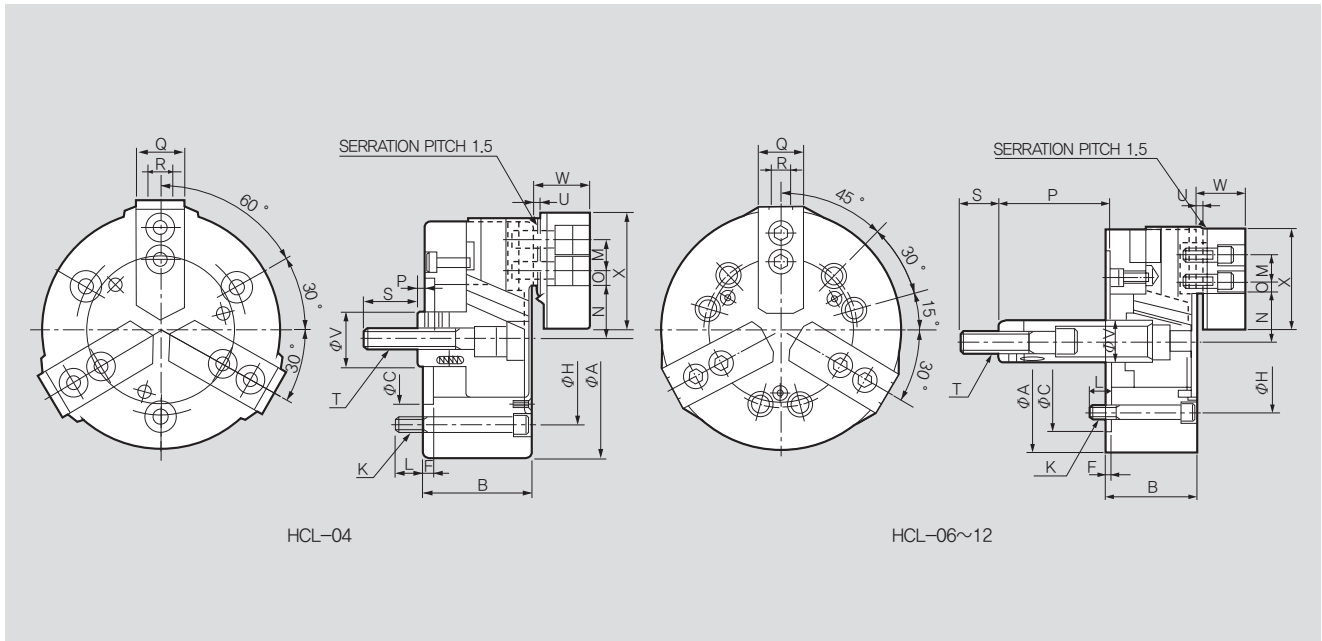

※ It is recommended to grease chucks at least twice a day in order to maximize longevity.

DIMENSIONS

	HCL-04	HCL-06	HCL-08	HCL-10	HCL-12
ΦA	110	165	210	254	304
B	52	74	85	89	106
$\Phi C(H6)$	60	140	170	220	220
F	6	5	5	5	6
ΦH	80	104.8	133.4	171.4	171.4
K	3-M8	6-M10	6-M12	6-M16	6-M16
L	12	14	20	18	18
M	14	20	25	30	30
N max.	26.5	40.5	48.1	54.4	65.7
N min.	20.45	34	40	43.35	56
O max.	9.75	13.75	20.75	29.5	42.75
O min.	6.75	9.25	11.75	11.5	12.75
P max.	18	101.5	131	161	163
P min.	3	81.5	106	133	133
Q	23	31	35	40	50
R	10	12	14	16	18
S	25	36	36	36	46
T	M10x1.5	M16x2.0	M20x2.5	M20x2.5	M20x2.5
U	3	4	5	5	5
ΦV	26	34	38	45	50
W	27	35	42	46	54
X	55	72	95	110	129

RELATED PRODUCT

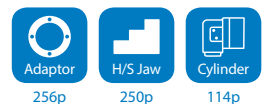

HCLT / HCLF 2-Jaw,4Jaw Closed-Center Long-Stroke Chuck



Application / Benefits

Ideal for vertical lathes and rectangular or square work that does not require a through hole

Technical features

Wedge hook style chuck with high gripping force

ACTUAL GRIPPING FORCE DIAGRAM

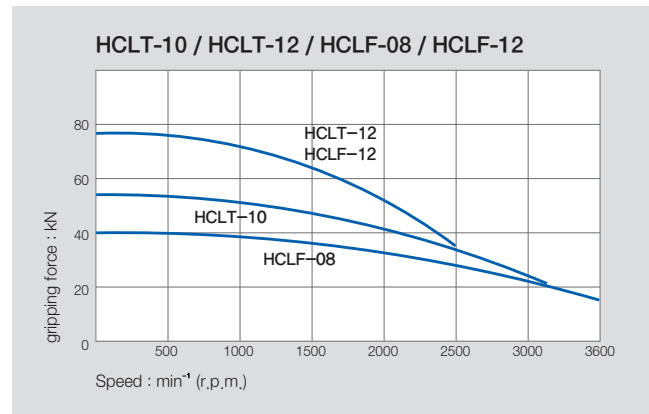
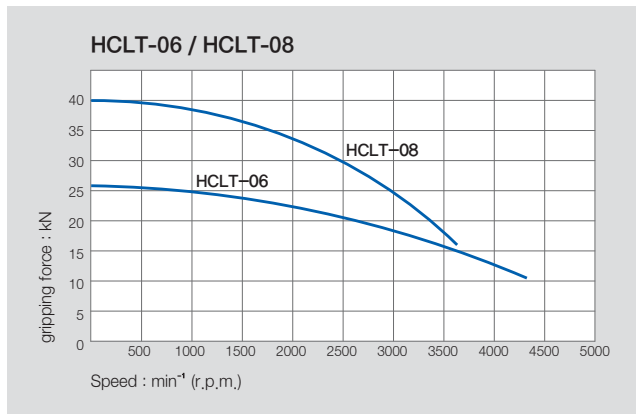

SPECIFICATIONS

	HCLT-06	HCLT-08	HCLT-10	HCLT-12	HCLF-08	HCLF-12
Jaw Stroke Dia. [mm]	13	16.2	18.1	19.4	16.2	19.4
Plunger Stroke [mm]	20	25	28	30	25	30
Grip Dia. Max [mm]	165	210	254	304	210	304
Grip Dia. Min [mm]	22	24	27	33	24	33
Max. Permissible Input Force [kN(kgf)]	14(1428)	20(2039)	27(2753)	36(3671)	20(2039)	36(3671)
Max. Static Gripping Force [kN(kgf)]	26(2651)	40(4079)	54(5508)	74(7546)	40(4079)	74(7546)
Max. r.p.m. [min ⁻¹]	4300	4300	3100	2500	3600	2500
Weight [kg]	12.5	12.5	35.5	60.5	24	60.5
Moment of inertia [N · m ² (kg · m ²)]	1.67(0.17)	1.67(0.17)	11.47(1.17)	27.75(2.83)	5.20(0.53)	27.75(2.83)
Max. Hydraulic Pressure [MPa(kgf/cm ²)]	2.06(21.0)	2.03(20.7)	1.93(19.7)	2.50(25.5)	2.03(20.7)	2.50(25.5)
Operating Cylinder	Y-1020R	Y-1225R	Y-1530R	Y-1530R	Y-1225R	Y-1530R
KITAGAWA® Model	NLT-06	NLT-08	NLT-10	NLT-12	NLT-08	NLT-12

※ Specifications are subject to change without notice.

※ Samchully Machinery Co., Ltd. is no longer an OEM manufacturer for Kitagawa® Iron Works Co., Ltd.

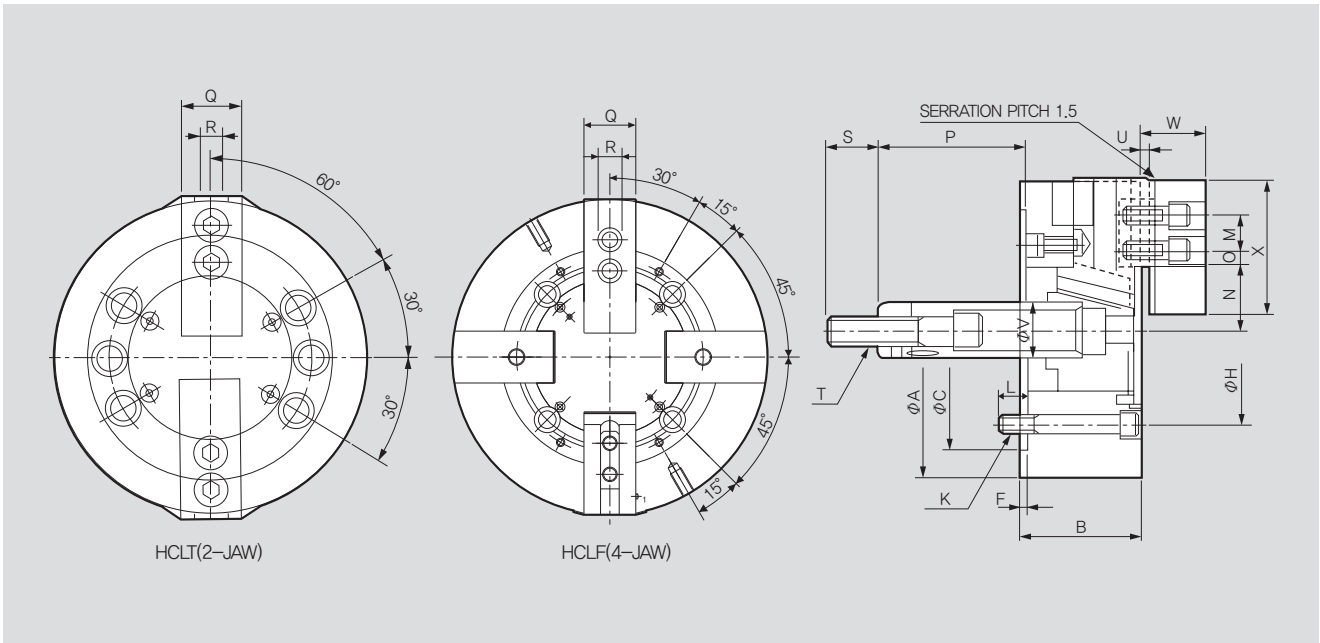

※ It is recommended to grease chucks at least twice a day in order to maximize longevity.

DIMENSIONS

	HCLT-06	HCLT-08	HCLT-10	HCLT-12	HCLF-08	HCLF-12
ΦA	165	210	253	304	210	304
B	74	85	89	106	85	106
$\Phi C(H6)$	140	170	220	220	170	220
F	5	5	5	6	5	6
ΦH	104.8	133.4	171.4	171.4	133.4	171.45
K	6-M10x70	6-M12x85	6-M16x105	6-M16x120	4-M16x85	4-M16x120
L	14	20	38	38	20	38
M	20	25	30	30	25	30
N max.	40.5	48.1	54.4	65.7	48.1	65.7
N min.	34	40	45.35	56	40	56
O max.	13.75	21	29.5	42.75	21	42.75
O min.	9.25	12	11.5	12.25	12	12.25
P max.	101.5	131	161	163	131	163
P min.	81.5	106	133	133	106	133
Q	31	35	40	50	35	50
R	12	14	16	18	14	18
S	36	36	36	36	36	36
T	M16x2.0	M20x2.5	M20x2.5	M20x2.5	M20x2.5	M20x2.5
U	4	5	5	5	5	5
ΦV	34	38	45	50	38	50
W	35	42	46	54	42	54
X	72	95	110	129	95	129

RELATED PRODUCT



HCWF 4-Jaw Double Wedge Power Chuck



Application / Benefits

For clamping round, cubic, pipe and geometrically irregular workpieces
Available with manual jaws

Technical features

Dual wedge for 2+2 clamping

ACTUAL GRIPPING FORCE DIAGRAM

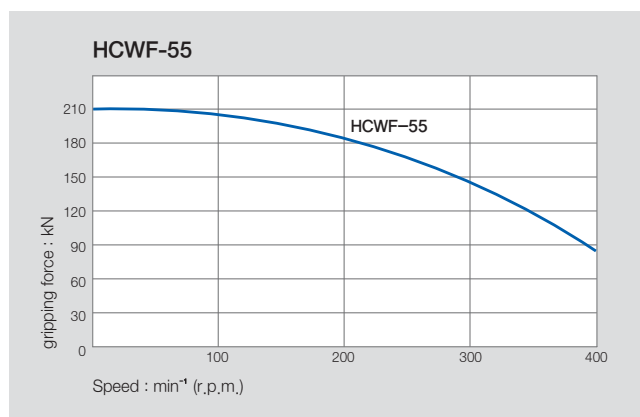

SPECIFICATIONS

	HCWF-55
2 Step Manual Jaw Function	☉
Manual Setting (Radial Chuck Jaw)	40+(24)
Manual Jaw Stroke Dia. [mm]	60
Plunger Stroke [mm]	60
Grip Dia. Max [mm]	1400
Grip Dia. Min [mm]	-
Max. Permissible Input Force [kN(kgf)]	120 (W1,W2)
Max.Static Gripping Force [kN]	210 (J1,J2)
Max. r.p.m. [min ⁻¹]	400
Weight [kg]	1400
Moment of inertia [N · m ² (kg · m ²)]	355(36.22)
Operating Cylinder	DYV-21560

※ ☉ = Option

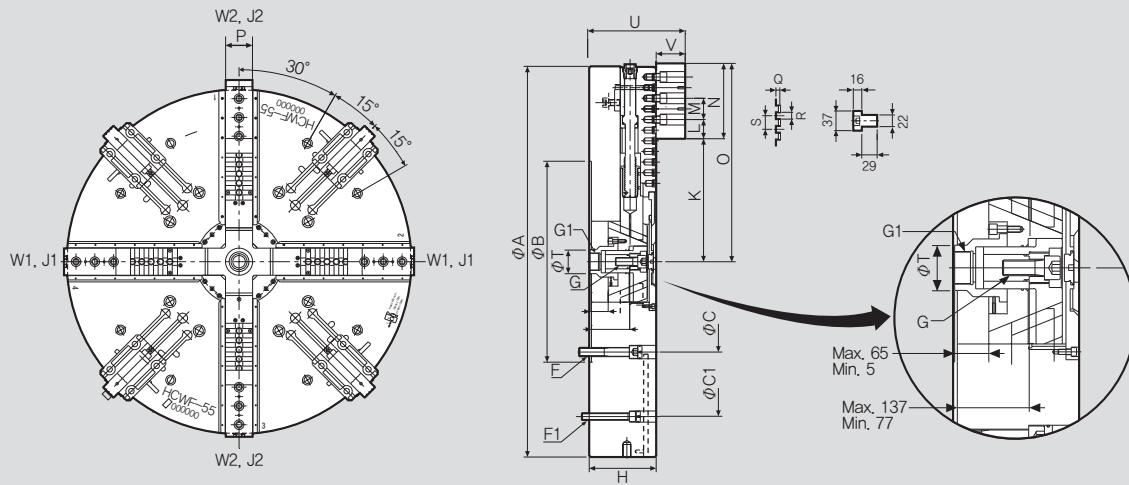

※ It is recommended to grease chucks at least twice a day in order to maximize longevity.

DIMENSIONS

HCWF-55			
ΦA	1400	L1max.	65
ΦB	720	L1min.	5
ΦC	647.6	L2max.	137
$\Phi C1$	1110	L2min.	77
D	26	M	76.2
E	40	N	270
F	M30x180	O	Max. 716
F1	M24x170	P	85
G	M30x80	Q	11
G1	M62x2.0	R	19.025
H	240	S	38.1
Kmax.	250	ΦT	110
Kmin.	226	U	343
		V	104

RELATED PRODUCT





ROTARY CYLINDER

Samchully cylinders buttress the high face value of our reputable chucks from within the machines. We have reached far and wide in becoming the industry standard thanks to our high quality, wide selection and compatibility with competing German and Japanese brands.



SD

Mega-Bore Short
body Open Center
Hydraulic Cylinder

104 P



YS-RA

Ultra Compact Closed
Center Hyd. Cylinder
with Proximity Bracket
& Built in Rotary Union

122 P



SH

Standard Mega Bore
Short Body Open
Center Hyd. Cylinder

106 P



DY

Double Piston
Hyd. Cylinder

124 P



SHL (Long Stroke)

Mega Bore Short
Body Open Center
Hyd. Cylinder

108 P



DYV

Double Piston Hyd.
Cylinder with Lock
Valve

126 P



SYH

Standard Open
Center Hyd. Cylinder

110 P



AY-R

Closed Center
Pneumatic Cylinder

128 P



SYHL (Long Stroke)

Open Center Hyd.
Cylinder

112 P



Y-R

Standard Closed
Center Hyd. Cylinder

114 P



Y-RE

Closed Center
Hyd. Cylinder with
Proximity Bracket

116 P



YH-RE

Ultra Compact Closed
Center Hyd. Cylinder
with Proximity Bracket

120 P

SD Mega-Bore Short body Open Center Hydraulic Cylinder



Application / Benefits

- Low drain rate
- Compact design
- Large bore for work requiring through hole

Technical features

- Low leakage minimizes heat
- Check valve maintains pressure during power outage

SPECIFICATIONS

	SD-13546	SD-15452	SD-17568	SD-18577	SD-18582	SD-21510	SDL-25411	SDL-30516
Available I.D. [mm]	46	52	68	77	82	103	117.5	166.5
Piston Dia. [mm]	132	156	170	185	185	215	250	305
Piston Stroke [mm]	25	25	29	29	30	35	50	51
Piston Force (Push) [kN(kgf)]	47(4800)	67(6800)	75(7656)	89(9000)	85(8700)	105(10700)	138(14100)	152(15483)
Piston Force (Pull) [kN(kgf)]	44(4500)	63(6400)	70(7050)	82(8300)	79(8100)	101(10300)	126(12900)	138(14060)
Max. Operating Pressure [MPa(kgf/cm ²)]	4.5(45bar)	4.5(45bar)	4.5(45bar)	4.5(45bar)	4.5(45bar)	4.5(45bar)	4.0(40bar)	3.3(33bar)
Max. r.p.m. [min ⁻¹]	7000	6200	5600	5000	4800	3500	3000	2000
Moment of inertia [N · m ² (kg · m ²)]	0.021	0.045	0.07	0.097	0.11	0.188	0.50	1.45
Weight [kg]	10	14	18	23	26	37	54	90
Total Leakage [l /min]	2.5	3	3.2	3.5	3.5	4.5	6	8.4

- ※ Maximum turning speed is based upon actual measurement.
- ※ Specifications are subject to change without notice.

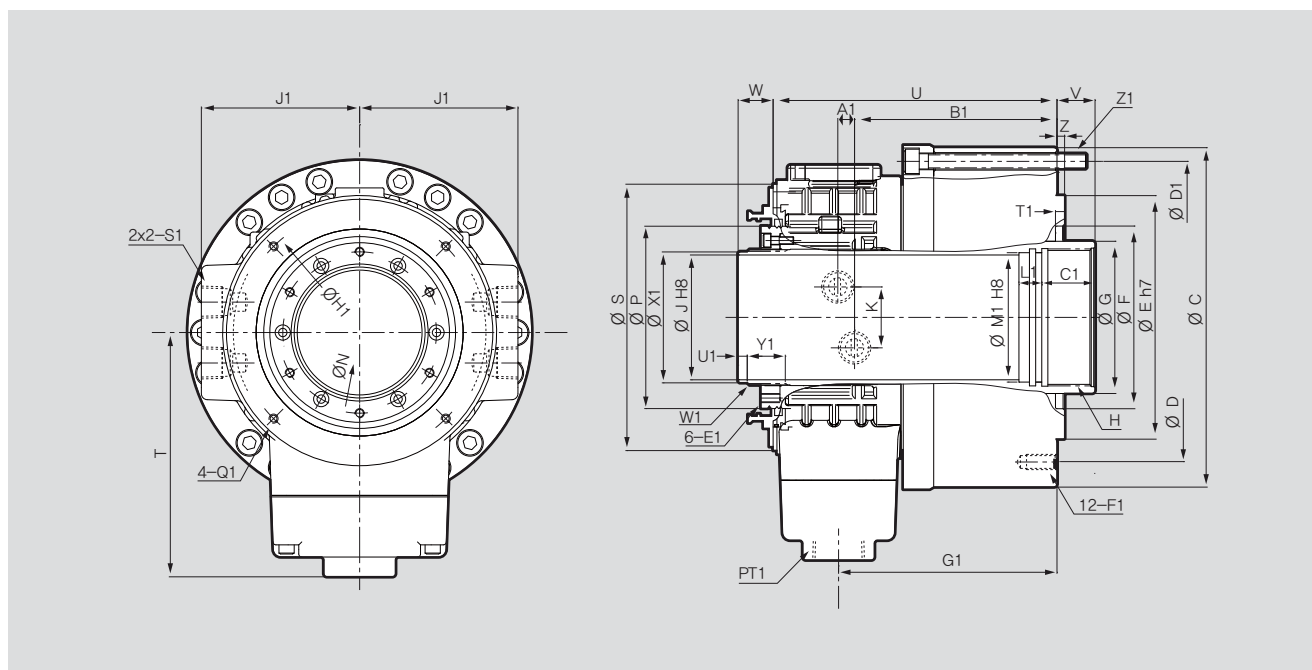

- ※ See the product dimension Table on the right.

DIMENSIONS

	SD-13546	SD-15452	SD-17568	SD-18577	SD-18582	SD-21510	SDL-25411	SDL-30516
ΦC	165	190	210	218	223	266	310	370
ΦD	130	170	190	190	190	225	275	290
ΦD1	147	170	190	200	205	240	275	345
ΦE(기준경)	100	130	160	160	160	200	230	260
ΦF	80	85	120	120	120	160	166	240
ΦG	65	70	85	95	100	125	140	190
H	M52x2.0p	M60x2.0p	M75x2.0p	M85x2.0p	M90x2.0p	M112x2.0p	M130x2.0p	M180x3.0p
ΦJ	46.5	52	68	77	82	103	117.5	166.5
K	36	36	40	40	40	48	46	42
N	63	76	92	102	106	128	138	188
ΦP	78.8	89.8	105.8	115.8	119.8	157.8	170	222
ΦS	116	135	154	164	175	205	230	278
T	119	134	141	149.5	160.5	174.5	204	230
U	159	150.5	172.5	182	186.5	203	258	290
V max	15	22	25	25	25	35	46	51
V min	-10	-3	-4	-4	-5	0	-4	0
W max	55	50	59	56	53	60	75	76
W min	30	25	30	27	23	25	25	25
Z	5	5	5	8	5	5	6	5
A1	8.5	8.5	11	11	11	14	18	17.5
B1	117.5	107.5	122.5	129.5	133	140	178.5	206
C1	30	30	30	35	35	30	45	45
E1	M6	M6	M6	M6	M6	M6	M6	M6
F1DP'	M10x20	M10x20	M10x20	M10x20	M10x20	M12x20	M16x32	M16x32
G1	125.5	115.5	132.5	139.5	143.5	152.5	194.5	221
H1	105	118	145	155	160	190	206	256
J1	75	80	90	95	104	120	135	160
K1	47	47	47	47	47	47	47	47
L1	15	15	21	15	15	15	20	20
M1	48	55	71	80	85	106	123	170
Q1	M5x10	M6x10	M6x10	M6x10	M6x12	M6x12	M6x12	M6x12
S1	PT1/2	PT1/2	PT1/2	PT1/2	PT1/2	PT1/2	PT1/2	PT1/2
T1	7	7	8	8	8	6	6	7
W1	M52x1.5p	M58x1.5p	M74x1.5p	M84x2.0p	M89x2.0p	M119x2.0p	M124x2.0p	M180x3.0p
ΦX1	50	56	71.5	81	86	116	121.5	170.5
Y1	24	20	28	26	25	38	29	45
U1	9	9	8	9	6	9	9	8
Z1	6-M8x90	6-M8x90	6-M10x95	8-M8x110	6-M10x110	6-M12x120	8-M12x140	6-M10x95

SH Standard Mega-Bore Short-Body Open Center Hydraulic Cylinder



Application / Benefits

Large bore for work requiring through hole
Compact design

Technical features

Check valve maintains pressure during power outage

SPECIFICATIONS

	SH-10036	SH-13046	SH-15052	SH-17068	SH-18077	SH-19082	SH-21010	SH-25011
Available I.D. [mm]	36	46	52	68	77	82	106	117.5
Piston Dia. [mm]	105	135	156	170	185	190	215	255
Piston Stroke [mm]	12	15	22	25	25	25	30	23
Piston Force (Push) [kN(kgf)]	25(2549)	42.3(4285)	60(6118)	63(6531)	75.3(7632)	78.1(7924)	91.8(9357)	132(13390)
Piston Force (Pull) [kN(kgf)]	24(2447)	38.1(3865)	56(5710)	59.8(6060)	69.6(7087)	72.5(7350)	87.8(8952)	121(12305)
Max. Operating Pressure [MPa(kgf/cm ²)]	4.0(40.8)	4.0(40.8)	4.0(40.8)	4.0(40.8)	4.0(40.8)	4.0(40.8)	4.0(40.8)	4.0(40.8)
Max. r.p.m. [min ⁻¹]	8000	7000	6200	5600	5000	4800	3500	3000
Moment of inertia [N · m ² (kg · m ²)]	0.43(0.044)	0.2(0.021)	0.44(0.045)	0.65(0.067)	0.83(0.084)	0.95(0.097)	1.84(0.188)	1.9(0.193)
Weight [kg]	8.4	10	14	16.5	18	25	37	50
Total Leakage [l /min]	3.0	3.0	3.9	4.0	4.2	4.5	6.0	7.0

※ Maximum turning speed is based upon actual measurement.
※ Specifications are subject to change without notice.

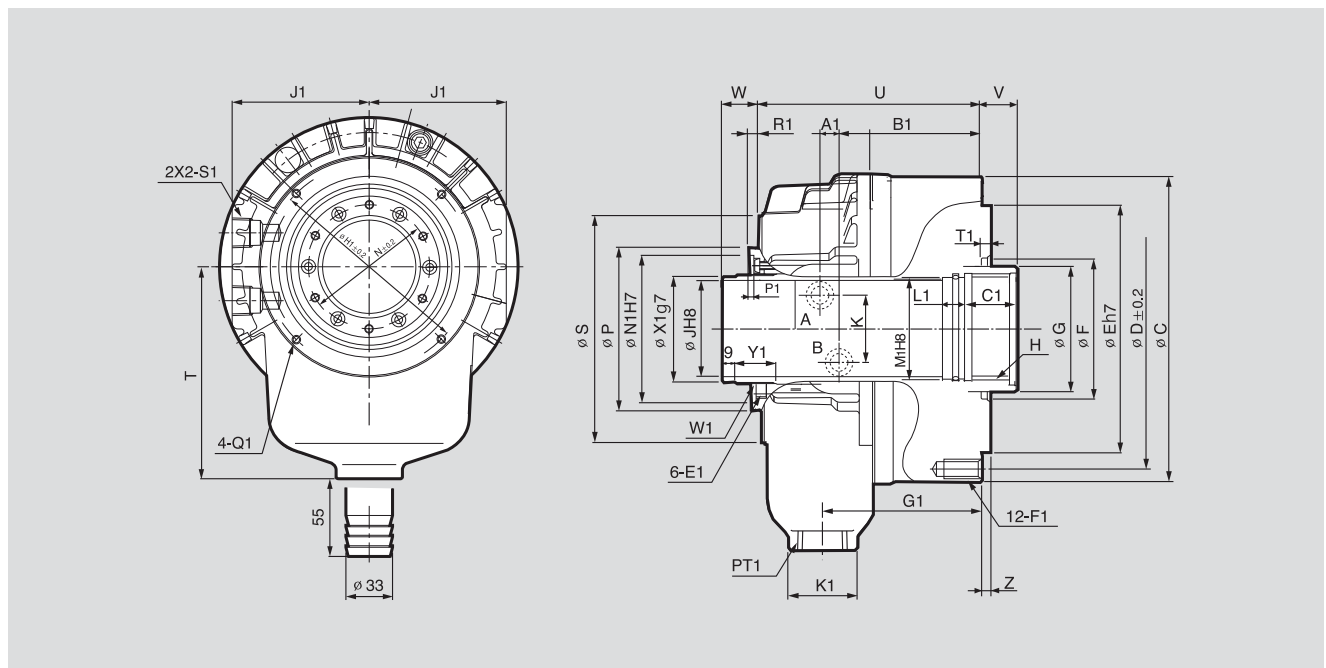

※ See the product dimension Table on the right.

DIMENSIONS

	SH-10036	SH-13046	SH-15052	SH-17068	SH-18077	SH-19082	SH-21010	SH-25011
ΦC	135	165	190	210	218	223	263	310
ΦD	115	130	170	190	190	190	225	275
ΦE (기준경)	100	100	130	160	160	160	200	230
ΦF	65	80	85	120	120	120	160	166
ΦG	48	65	70	85	95	100	125	140
Hmax.	M42x1.5	M52x2.0	M60x2.0	M75x2.0	M85x2.0	M90x2.0	M115x2.0	M130x2.0
ΦJ	36	46	52	68	77	82	106	117.5
K	30	40	40	48	48	58	48	46
N	55	64	73	88	98	103	142	138
ΦP	73	85	96	111	121	126	157.8	170
ΦS	104	116	135	154	164	175	205	230
T	115	120	130	150	165	166	195	107.5
U	130	142	136	155	167	174	199.7	231
V max.	15	15	22	25	25	25	30	18
V min.	3	0	0	0	0	0	0	-5
W max.	37	40	47	50	50	44	55	48
W min.	25	25	25	25	25	19	25	25
Z	5	5	5	5	5	5	5	6
A1	9	8.5	9	10	10	11.5	14	19
B1	90	103	97.5	108	119.5	122	136.5	150
C1	25	30	30	35	35	35	35	45
E1	M5	M6	M6	M6	M6	M6	M6	M6
F1DP'	M10x17	M10x20	M10x20	M10x20	M10x20	M12x20	M12x20	M16x32
G1	93.5	111	101	113	125	129.5	151	163.5
H1	96	105	118	145	155	160	190	206
J1	73	82	92	97	102	105	120	140
K1	47	47	47	47	47	47	47	55
L1	15	15	15	15	15	15	15	20
ΦM1	38	48	55	70	80	85	110	123
ΦN1	64	76	85	100	108	113	128	150
P1	4	4	4	4	4	4	4	5.5
Q1	M5x7	M5x6	M6x7	M6x10	M6x10	M6x10	M6x10	M6x12
R1	5	6	7	7	7	7	7	7.5
S1	PT 1/2	PT 1/2	PT 1/2	PT 1/2	PT 1/2	PT 1/2	PT 1/2	PT 1/2
T1	6	6	5.5	5	5	6	6	6
W1	M44x1.5	M52x1.5	M58x1.5	M74x1.5	M84x2.0	M89x2.0	M119x2.0	M124x2.0
ΦX1	42	50	56	72.5	81	86	116	122
Y1	30	24	20	26	26	26	38	29

SHL Mega-Bore Short-Body Long-Stroke Open Center Hydraulic Cylinder



Application / Benefits

For work requiring through hole and long stroke

Technical features

Check valve maintains pressure during power outage

SPECIFICATIONS

	SHL-17068	SHL-18077	SHL-25011	SHL-39024
Available I.D. [mm]	68	77	117.5	240
Piston Dia. [mm]	170	185	255	390
Piston Stroke [mm]	40	40	50	51
Piston Force (Push) [kN(kgf)]	63(6531)	75.3(7632)	132(13390)	152.5(15570)
Piston Force (Pull) [kN(kgf)]	59.8(6060)	69.6(7087)	121(12305)	138.7(14152)
Max. Operating Pressure [MPa(kgf/cm ²)]	4.0(40.8)	4.0(40.8)	4.0(40.8)	2.5(25)
Max. r.p.m. [min ⁻¹]	5600	5000	3000	1500
Moment of inertia [N · m ² (kg · m ²)]	0.69(0.070)	0.86(0.088)	1.9(0.193)	39.64(4.045)
Weight [kg]	17.8	18.5	54	140
Total Leakage [l /min]	4	4.2	7	22

※ Specifications are subject to change without notice.

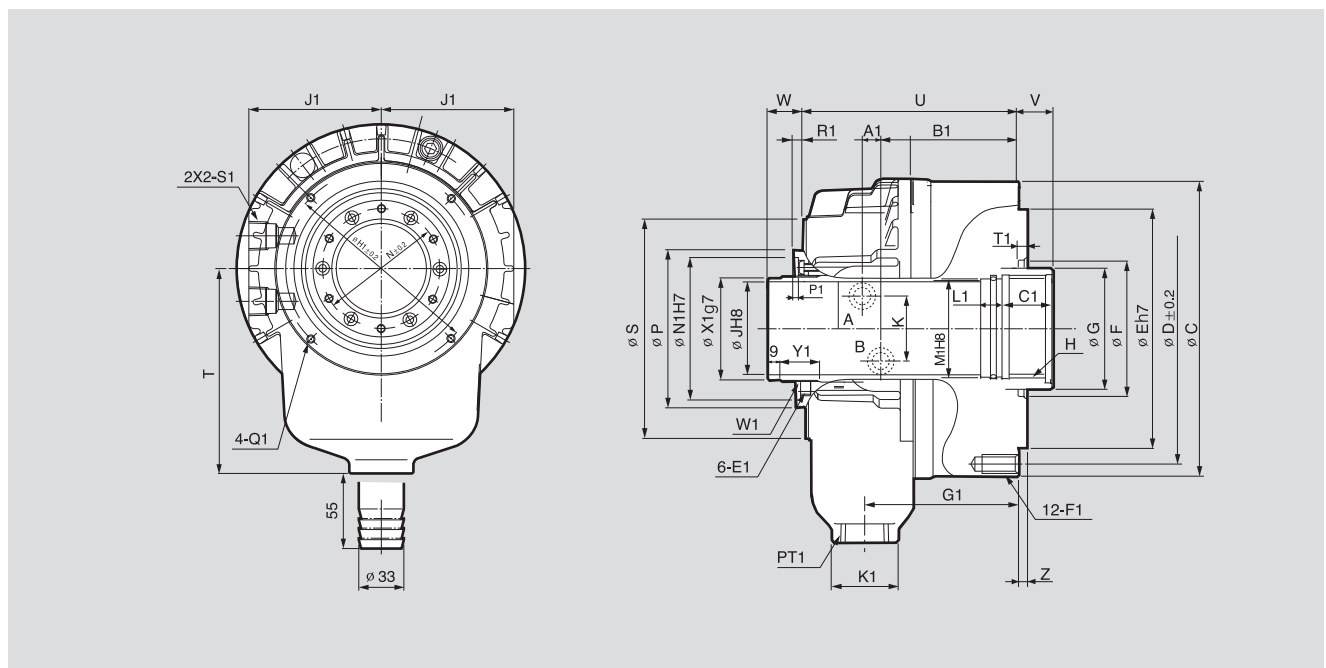

※ See the product dimension Table on the right.

DIMENSIONS

	SHL-17068	SHL-18077	SHL-25011	SHL-39024
ΦC	210	218	310	450
ΦD	190	190	275	420
ΦE (기준경)	160	160	230	320
ΦF	120	120	166	280
ΦG	85	95	140	265
H max.	M75x2.0	M85x2.0	M130x2.0	M250x3.0
ΦJ	68	77	117.5	240
K	48	48	46	30
ΦN	88	98	138	268
ΦP	111	121	170	310
ΦS	154	164	230	370
T	150	165	107.5	340
U	175	182	258	302.5
V max.	35	35	46	50
V min.	-5	-5	-4	-1
W max.	65	65	87	76
W min.	25	25	37	25
Z	5	5	6	6
A1	10	10	19	22
B1	128	134.5	176.5	199
C1	35	35	45	45
E1	M6	M6	M6	M6
F1DP'	M10x20	M10x20	M16x32	M16x40
G1	133	140	190.5	215
H1	145	155	206	350
J1	97	102	140	215
K1	47	47	55	75
L1	15	15	120	20
M1	71	80	123	243
N1	100	108	150	284
P1	4	4	5.5	5.5
Q1	M6x10	M6x10	M6x12	M6x12
R1	7	7	7.5	7.5
S1	PT 1/2	PT 1/2	PT 1/2	PT 1/2
T1	5	5	6	6
W1	M74x1.5	M84x2.0	M124x2.0	M253x2.0
ΦX1	72.5	81	122	249
Y1	26	26	29	38

SYH Standard Open Center Hydraulic Cylinder



Application / Benefits

Compact and lightweight
For work requiring through hole

Technical features

Check valve maintains pressure during power outage

SPECIFICATIONS

	SYH-1036	SYH-1246	SYH-1552	SYH-1877	SYH-2091
Available I.D. [mm]	36	36,39,40,41,43,45,46	46,52,69	68,69,75,77	78,91
Piston Dia. [mm]	105	125	155	180	205
Piston Stroke [mm]	15	15	22	25	30
Piston Surface Area (Push) [cm ²]	67	100	161	198	252
Piston Surface Area (Pull) [cm ²]	64.5	89	150	183	234
Piston Force (Push) Push [kN(kgf)]	25(2549)	38(3875)	60(6118)	74(7546)	94(9584)
Piston Force (Pull) Push [kN(kgf)]	24(2447)	33(3365)	56(5710)	69(7036)	88(8973)
Max. Operating Pressure [MPa(kgf/cm ²)]	4.0(40.8)	4.0(40.8)	4.0(40.8)	4.0(40.8)	4.0(40.8)
Max. r.p.m. [min ⁻¹]	8000	8000	6200	4700	3800
Moment of inertia [N · m ² (kg · m ²)]	0.10(0.011)	0.18(0.019)	0.52(0.053)	0.93(0.095)	1.45(0.153)
Weight [kg]	8.6	12	16.8	26	33
Total leakage [l /min]	3	3	3.9	4.2	4.5
KITAGAWA® Model	S-1036	S-1246	S-1552	S-1875	S-2091

※ Maximum turning speed is based upon actual measurement.
※ Specifications are subject to change without notice.

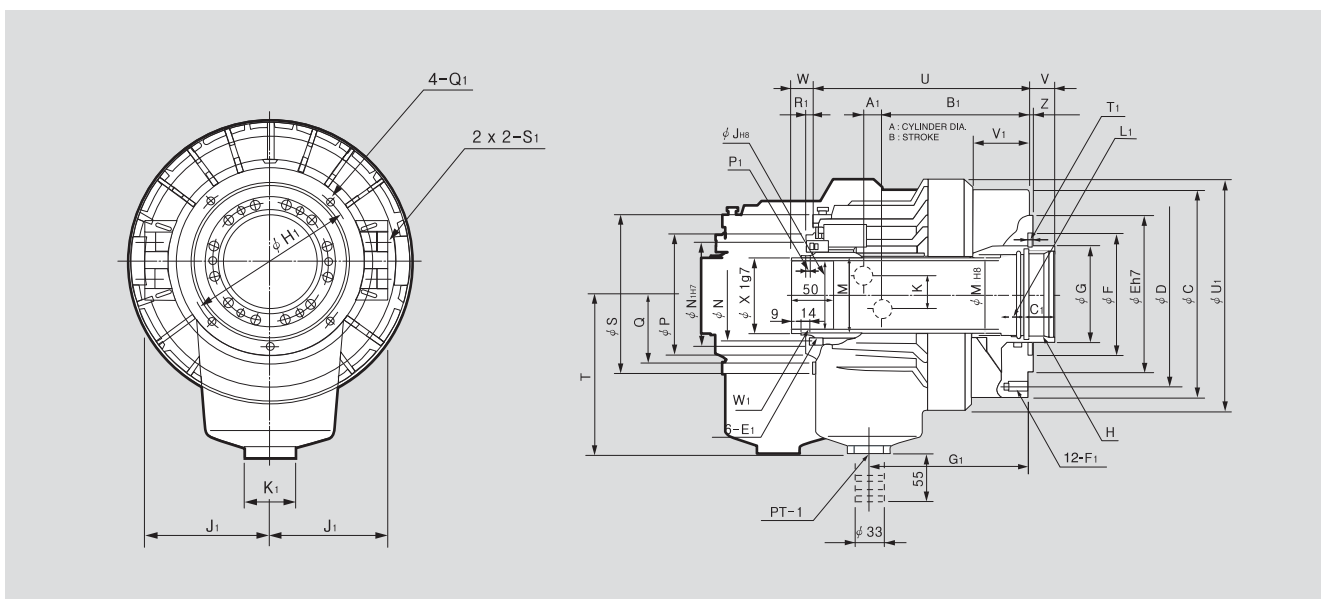

※ See the product dimension Table on the right.

DIMENSIONS

	SYH-1036	SYH-1246	SYH-1552	SYH-1877	SYH-2091
ΦC	135	155	190	215	240
ΦD	115	130	170	190	215
ΦE	100	100	130	160	180
ΦF	65	80	85	120	140
ΦG	48	65	70	95	110
H max.	M42x1.5	M52x2.0	M60x2.0	M85x2.0	M100x2.0
ΦJ	36	46	52	77	91
K	30	36	36	36	34
ΦM	44.6	52.9	59.6	84.6	99.6
ΦN	55	64	73	98	108
ΦP	73	85	96	121	138
ΦQ	45	51.5	57	70	79
ΦS	104	118	137	166	182
T	115	115	130	160	185
U	156	184	191	230	253
V max.	15	15	22	25	30
V min.	0	0	0	0	0
W max.	40	40	47	50	55
W min.	25	25	25	25	25
Z	5	5	5	5	5
A1	11	11.5	12	17.5	21
B1	102.5	126.5	136	153.5	168
C1	25	30	30	35	35
E1	M5x11	M6x9	M6x9	M6x9	M6x14
F1	6-M10x17	12-M10x20	12-M10x20	12-M10x20	12-M12x24
G1	98	135	145	166.5	183
H1	88	98	110	155	165
J1	73	76	86	101	110
K1	47	47	47	47	47
L1	15	15	15	15	15
M1	38	50	55	80	95
ΦN1	64	76	85	108	120
P1	4	4	4	4	4
Q1	M5x10	M5x10	M6x12	M6x12	M6x12
R1	5	6	7	7	7
S1	PT3/8	PT1/2	PT1/2	PT1/2	PT1/2
T1	6	6	6	6	6
ΦU1	158	200	220	242	267
V1	28	46	51	58	66
W1	M44x1.5	M52x1.5	M58x1.5	M84x2.0	M99x2.0
ΦX1	42	50	56	81	96

SYHL Open Center Long-Stroke Hydraulic Cylinder



Application / Benefits

For work requiring through hole and long stroke

Technical features

Check valve maintains pressure during power outage

SPECIFICATIONS

	SYHL-1246	SYHL-1552	SYHL-1877	SYHL-2091	SYHL-2816
Available I.D. [mm]	46	52	68,75,77	91	166.5
Piston Dia. [mm]	125	155	180	205	280
Piston Stroke [mm]	32	34	40	50	51
Piston Surface Area (Push) [cm ²]	100	161	198	252	377
Piston Surface Area (Pull) [cm ²]	89	150	183	234	332
Piston Force (Push) [kN(kgf)]	38(3875)	60(6118)	74(7546)	94(9585)	113(11522)
Piston Force (Pull) [kN(kgf)]	33(3365)	56(5710)	69(7063)	88(8973)	100(10196)
Max. Operating Pressure [MPa(kgf/cm ²)]	4.0(40.8)	4.0(40.8)	4.0(40.8)	4.0(40.8)	3.3(33.6)
Max. r.p.m. [min ⁻¹]	7000	6200	4700	3800	2000
Moment of inertia [N · m ² (kg · m ²)]	0.21(0.022)	0.56(0.058)	0.10(0.098)	1.56(0.160)	35.5(3.31)
Weight [kg]	12.8	17	26.8	34.1	101
Total leakage [l /min]	3	3.9	4.2	4.5	8.4
KITAGAWA® Model	S-1246L	S-1552L	S-1875L	S-2091L	S-2816L

- ※ Specifications are subject to change without notice.
- ※ Certain models have several thru-hole sizes available.
- ※ The bore threading varies by model. H max represents the largest possible threading.

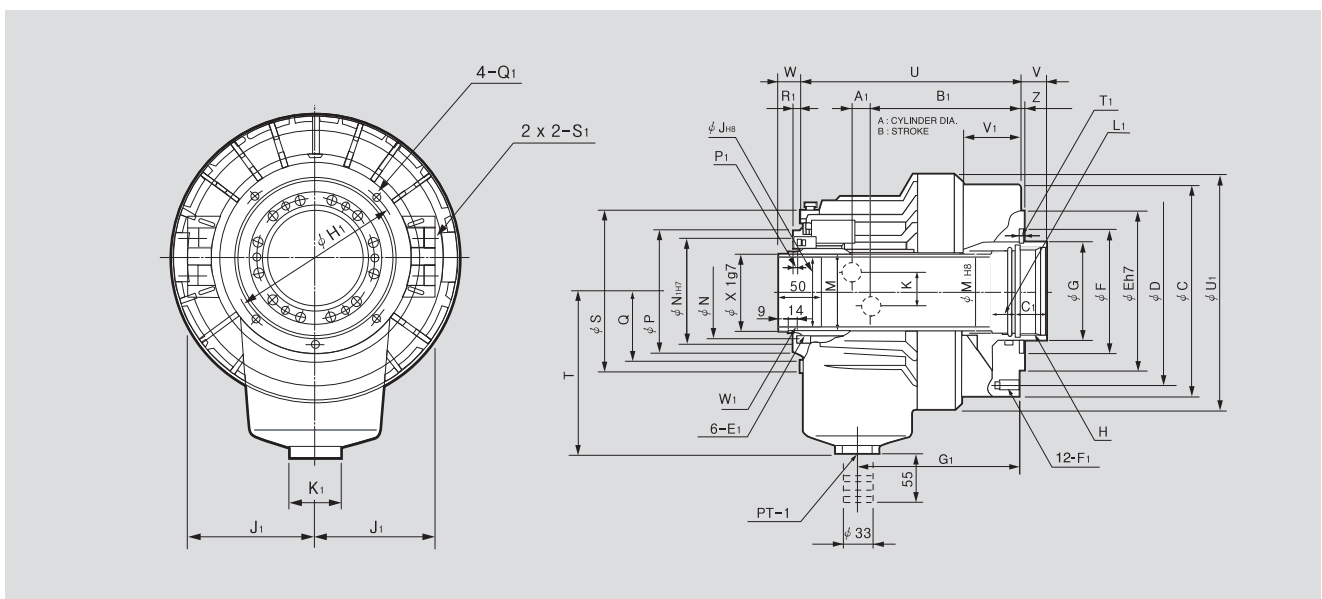

※ See the product dimension Table on the right.

DIMENSIONS

	SYHL-1246	SYHL-1552	SYHL-1877	SYHL-2091	SYHL-2816
ΦC	155	190	215	240	325
ΦD	130	170	190	215	290
ΦE	100	130	160	180	260
ΦF	80	85	120	140	240
ΦG	65	70	95	110	190
H max.	M55x2.0	M60x2.0	M85x2.0	M100x2.0	M180x3.0
ΦJ	46	52	77	91	166.5
K	36	36	36	34	30
ΦM	52.9	59.6	84.6	99.6	174.6
ΦN	64	73	98	108	188
ΦP	85	96	121	138	222
Q	51.5	57	70	79	120
ΦS	118	137	166	182	282
T	115	130	160	185	250
U	205	208	246	273	370
V	27	29	35	50	51
V	-5	-5	-5	0	0
W	57	59	65	75	76
W	25	25	25	25	25
Z	5	5	5	5	5
A1	11.5	12	17.5	21	28
B1	147.5	153	169.5	188	259
C1	30	30	35	35	45
E1	M6x9	M6x9	M6x9	M6x14	M6x12
F1	M10x20	M10x20	M10x20	M12x24	M16x32
G1	156	162	182.5	203	276
H1	98	110	155	165	256
J1	76	86	101	110	162
K1	47	47	47	47	47
L1	15	15	15	15	20
M1	50	55	80	95	170
ΦN1	76	85	108	120	200
P1	4	4	4	4	4
Q1	M5x10	M6x12	M6x12	M6x12	M6x12
R1	6	7	7	7	7
S1	PT1/2	PT1/2	PT1/2	PT1/2	PT1/2
T1	12	12	12	12	7
ΦU1	200	220	242	267	352
V1	67	68	74	86	123
W1	M52x1.5	M58x1.5	M84x2.0	M99x2.0	M173x2.0
ΦX1	50	56	81	96	170.5

Y-R Standard Closed-Center Hydraulic Cylinder



Application / Benefits

For closed center chucks and work not requiring spindle through

Technical features

Check valve maintains pressure during power outage

SPECIFICATIONS

	Y-0715R	Y-1020R	Y-1225R	Y-1530R	Y-2035R
Piston Stroke [mm]	15	20	25	30	35
Piston Surface Area (Push) [cm ²]	44	86	122	176	314
Piston Surface Area (Pull) [cm ²]	37	79	113	160	290
Piston Force (Push) [kN(kgf)]	16.6(1693)	32.0(3264)	46.0(4692)	66.0(6732)	117.0(11934)
Piston Force (Pull) [kN(kgf)]	13.9(1417)	29(2957)	42(4283)	60(6118)	108(11013)
Max. Operating Pressure [MPa(kgf/cm ²)]	4.0(40.8)	4.0(40.8)	4.0(40.8)	4.0(40.8)	4.0(40.8)
Max. r.p.m. [min ⁻¹]	6000	6000	6000	5500	5500
Moment of inertia [N · m ² (kg · m ²)]	0.118(0.012)	0.49(0.05)	0.88(0.09)	1.86(0.19)	3.82(0.39)
Weight [kg]	4	7.1	10	13.5	22
Total leakage [l /min]	0.8	0.8	0.8	0.8	0.8
KITAGAWA® Model	Y-0715R	Y-1020R	Y-1225R	Y-1530R	Y-2035R

- ※ Specifications are subject to change without notice.
- ※ Piston forces measured at max pressure of 4.0MPa (40.8 kgf/cm²)
- ※ Total leakage measured at cylinder pressure of 3.0MPa(30.6 kgf/cm²) and oil temperature at
- ※ Samchully Machinery Co., Ltd. is no longer an OEM manufacturer for kitagawa Iron Works Co., Ltd

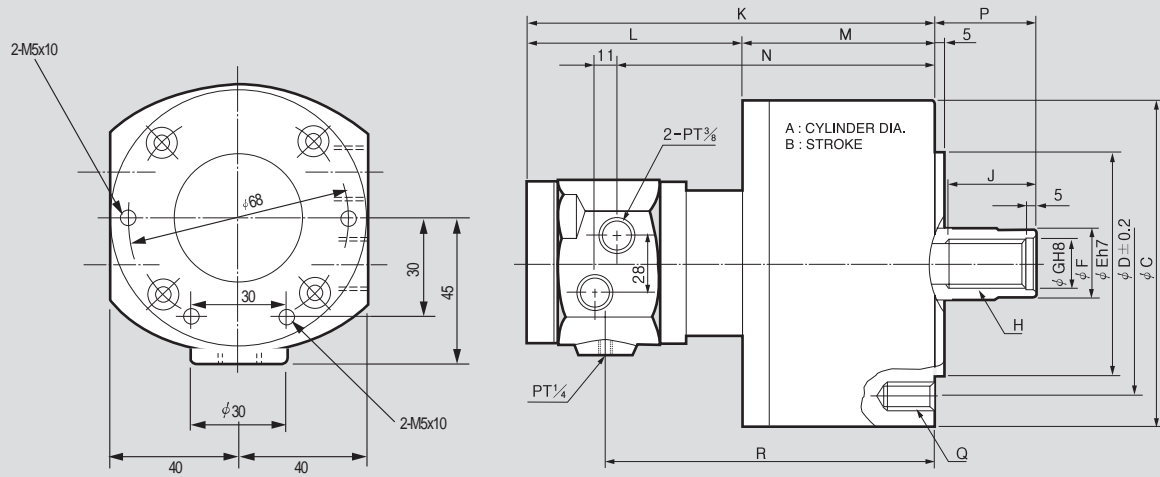

DIMENSIONS

	Y-0715R	Y-1020R	Y-1225R	Y-1530R	Y-2035R
A	75	105	125	150	200
B	15	20	25	30	35
ΦC	104	135	160	190	245
ΦD	90	100	130	130	145
ΦE	65	80	110	110	120
ΦF	30	30	35	45	55
ΦG	21	21	25	31	37
H max.	M20x2.5	M20x2.5	M24x3.0	M30x3.5	M36x4.0
J	35	35	44	45	60
K	172	197	205	214	228
L	106	108	108	108	106
M	66	89	97	106	122
N	127	152	160	169	183
P max.	46	45	51	56	69
P min.	31	25	26	26	34
Q	6-M6x20	6-M10x20	6-M12x24	6-M12x24	12-M16x30
R	133	158	166	175	189

Y-RE Closed-Center Hydraulic Cylinder with Proximity Bracket (75mm~125mm)

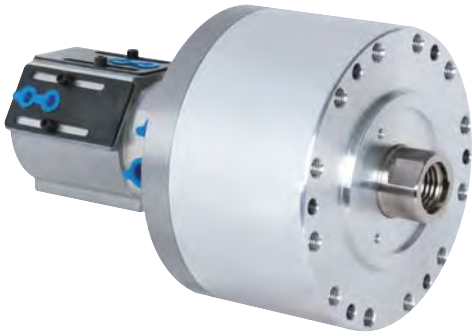

Application / Benefits

For work not requiring through spindle
Includes brackets for proximity switches (switches not included)

Technical features

Check valve maintains pressure during power outage

SPECIFICATIONS

	Y-0715RE	Y-1020RE	Y-1025RE	Y-1225RE	Y-1240RE
Piston Stroke [mm]	15	20	25	25	40
Piston Surface Area (Push) [cm ²]	44	84	84	120	120
Piston Surface Area (Pull) [cm ²]	37	79	79	113	113
Piston Force (Push) [kN(kgf)]	16.6(1693)	32.0(3264)	32.0(3264)	46.0(4692)	46.0(4692)
Piston Force (Pull) [kN(kgf)]	13.9(1417)	29(2957)	29(2957)	42(4283)	42(4283)
Max. Operating Pressure [MPa(kgf/cm ²)]	4.0(40.8)	4.0(40.8)	4.0(40.8)	4.0(40.8)	4.0(40.8)
Max. r.p.m. [min ⁻¹]	6000	6000	6000	6000	6000
Moment of inertia [N · m ² (kg · m ²)]	0.118(0.012)	0.46(0.05)	0.49(0.05)	0.88(0.09)	0.88(0.09)
Weight [kg]	4.5	7.6	7.7	10.5	11
Total leakage [l /min]	0.8	0.8	0.8	0.8	0.8
KITAGAWA® Model	Y-0715RE	Y-1020RE	Y-1025RE	Y-1225RE	Y-1240RE

- ※ Specifications are subject to change without notice.
- ※ Piston forces measured at max pressure of 4.0MPa (40.8 kgf/cm²)
- ※ Total leakage measured at cylinder pressure of 3.0MPa(30.6 kgf/cm²) and oil temperature at
- ※ Samchully Machinery Co., Ltd. is no longer an OEM manufacturer for kitagawa Iron Works Co., Ltd

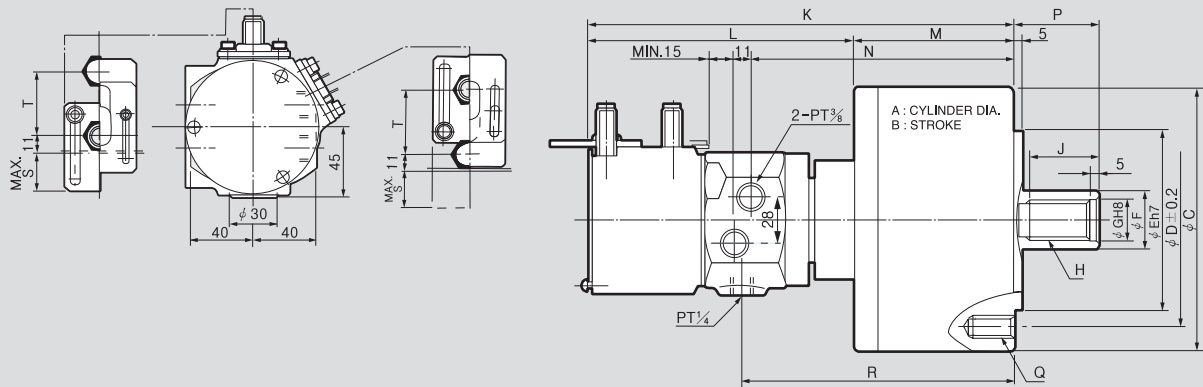

DIMENSIONS

	Y-0715RE	Y-1020RE	Y-1025RE	Y-1225RE	Y-1240RE
A	75	105	105	125	125
B	15	20	25	25	40
ΦC	104	135	135	160	160
ΦD	90	100	100	130	130
ΦE	65	80	80	110	110
ΦF	30	30	30	35	35
ΦG	21	21	21	25	25
H	M20x2.5	M20x2.5	M20x2.5	M24x3.0	M24x3.0
J	32	35	35	44	44
K	227	252	257	260	306
L	161	163	163	163	194
M	66	89	94	97	112
N	127	152	157	160	175
P max.	46	45	45	51	65
P min.	31	25	20	26	25
Q	6-M6x20	6-M10x20	6-M10x20	6-M12x24	6-M12x24
R	133	158	163	166	181
S	23	23	23	23	-
T	41	41	41	41	-

Y-RE Closed-Center Hydraulic Cylinder with Proximity Bracket (150mm~250mm)



Application / Benefits

For work not requiring through spindle
Includes brackets for proximity switches (switches not included)

Technical features

Check valve maintains pressure during power outage

SPECIFICATIONS

	Y-1530RE	Y-1550RE	Y-2035RE	Y-2050RE	Y-2560RE
Piston Stroke [mm]	30	50	35	50	60
Piston Surface Area (Push) [cm ²]	174	174	312	312	515
Piston Surface Area (Pull) [cm ²]	160	160	290	290	482
Piston Force (Push) [kN(kgf)]	66.0(6732)	66.0(6732)	117.0(11934)	117.0(11934)	193(19541)
Piston Force (Pull) [kN(kgf)]	60(6118)	60(6118)	108(11013)	108(11013)	180(18289)
Max. Operating Pressure [MPa(kgf/cm ²)]	4.0(40.8)	4.0(40.8)	4.0(40.8)	4.0(40.8)	4.0(40.8)
Max. r.p.m. [min ⁻¹]	5500	5500	5500	5500	2000
Moment of inertia [N · m ² (kg · m ²)]	1.86(0.19)	1.96(0.20)	3.82(0.39)	4.12(0.42)	9.0(0.92)
Weight [kg]	14	14.8	22.5	23.5	85
Total leakage [ℓ /min]	0.8	0.8	0.8	0.8	0.8
KITAGAWA® Model	Y-1530RE	Y-1550RE	Y-2035RE	Y-2050RE	-

- ※ Specifications are subject to change without notice.
- ※ Piston forces measured at max pressure of 4.0MPa (40.8 kgf/cm²)
- ※ Total leakage measured at cylinder pressure of 3.0MPa(30.6 kgf/cm²) and oil temperature at
- ※ Samchully Machinery Co., Ltd. is no longer an OEM manufacturer for kitagawa Iron Works Co., Ltd

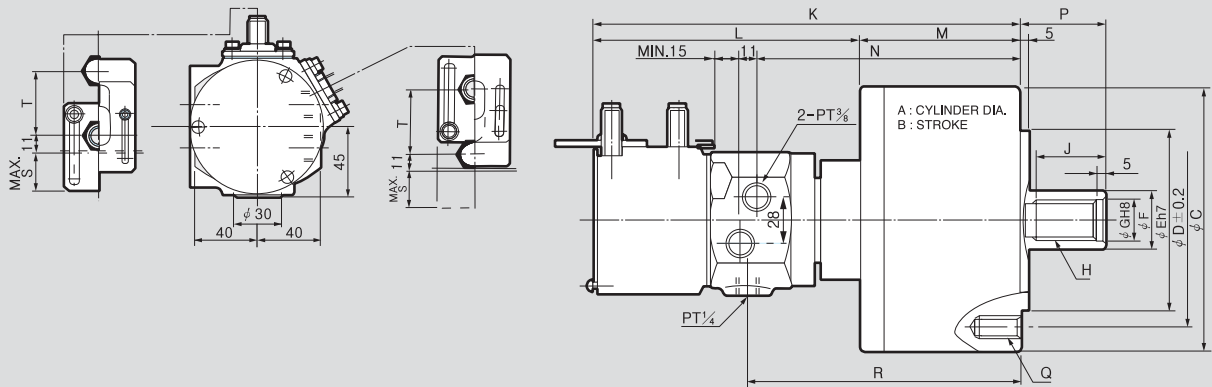

DIMENSIONS

	Y-1530RE	Y-1550RE	Y-2035RE	Y-2050RE	Y-2560RE
A	150	150	200	200	250
B	30	50	35	50	60
ΦC	190	190	245	245	305
ΦD	130	130	145	145	220
ΦE	110	110	120	120	160
ΦF	45	45	55	55	65
ΦG	31	31	37	37	44
H	M30x3.5	M30x3.5	M36x4.0	M36x4.0	M42x3.0
J	45	55	60	60	65
K	269	320	288	333	379
L	163	194	166	192	207
M	106	126	122	141	172
N	169	189	183	202	227
P max.	56	80	69	80	85
P min.	26	30	34	30	25
Q	6-M12x24	6-M12x24	12-M16x30	12-M16x30	12-M20x35
R	175	195	189	208	233
S	23	-	28	-	-
T	41	-	46	-	-

YH-RE

Ultra-Compact Closed-Center Hydraulic Cylinder with Proximity Bracket



Application / Benefits

Ultra compact closed center cylinder with brackets for proximity switches (switches not included)

Technical features

Check valve maintains pressure during power outage

SPECIFICATIONS

	YH-10120RE	YH-10125RE	YH-12125RE	YH-12140RE	YH-15130RE	YH-15150RE	YH-20135RE	YH-20150RE	YH-25160RE
Piston Stroke [mm]	20	25	25	40	30	50	35	50	60
Piston Surface Area (Push) [cm ²]	78	78	114	114	168	168	305	305	515
Piston Surface Area (Pull) [cm ²]	73	73	106	106	154	154	283	283	482
Piston Force (Push) [kN(kgf)]	29(2960)	29(2960)	42(4326)	42(4326)	63(6375)	63(6375)	114(11573)	114(11573)	193(19541)
Piston Force (Pull) [kN(kgf)]	27(2770)	27(2770)	39(4022)	39(4022)	57(5843)	57(5843)	105(10738)	105(10738)	180(18289)
Max. Operating Pressure [MPa(kgf/cm ²)]	40(40.8)	40(40.8)	40(40.8)	40(40.8)	40(40.8)	40(40.8)	40(40.8)	40(40.8)	40(40.8)
Max. r.p.m. [min ⁻¹]	6000	6000	6000	6000	5500	5500	5500	5500	2000
Moment of inertia [N · m ² (kg · m ²)]	0.49(0.05)	0.49(0.05)	0.88(0.09)	0.88(0.09)	1.86(0.19)	1.96(0.2)	3.82(0.39)	4.12(0.42)	9(0.92)
Weight [kg]	7.6	7.7	10.5	11	14	14.5	22.5	23.5	88
Total leakage [ℓ /min]	0.8	0.8	0.8	0.8	0.8	0.8	0.8	0.8	0.8

※ Specifications are subject to change without notice.

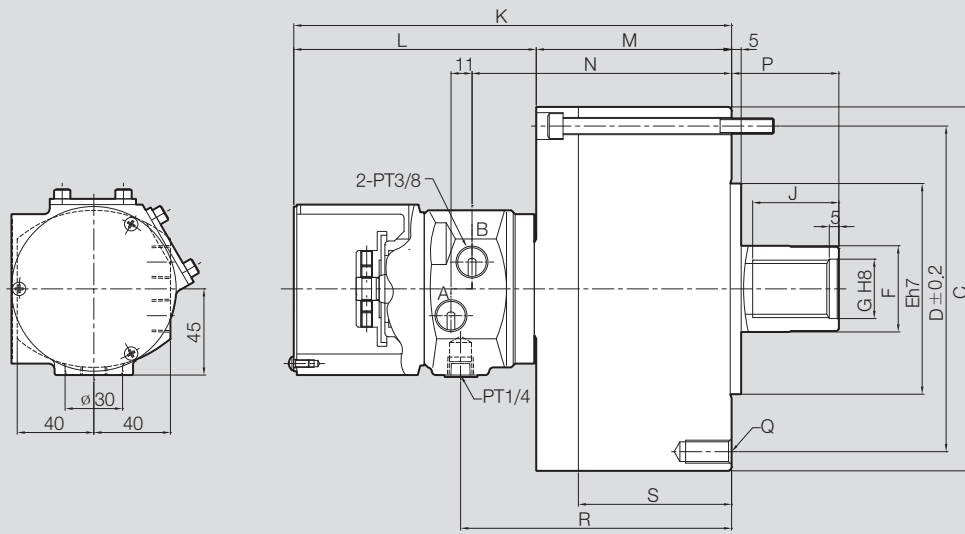

DIMENSIONS

	YH-10120RE	YH-10125RE	YH-12125RE	YH-12140RE	YH-15130RE	YH-15150RE	YH-20135RE	YH-20150RE	YH-25160RE
ΦC	135	135	160	160	190	190	245	245	305
ΦD	118	118	142	142	170	170	222	222	275
ΦE	80	80	110	110	110	110	120	120	160
ΦF	30	30	35	35	45	45	55	55	65
ΦG	21	21	25	25	31	31	37	37	44
J	35	35	44	44	45	55	60	60	65
K	209.6	214.6	220.6	267.1	228.6	280.1	240.6	280.1	310
L	126.6	126.6	126.6	156.6	126.6	158.1	133.6	158.1	136
M	83	88	94	109	102	122	107	122	142.5
N	116.5	121.5	127.5	142.5	135.5	155.5	140.5	155.5	176
P max.	45	45	51	65	56	80	69	80	85
P min.	25	20	26	25	26	30	34	30	25
Q	6-M10x20	6-M10x20	12-M12x24	12-M12x24	12-M12x24	12-M12x24	12-M16x30	12-M16x30	12-M20x35
R	122.5	127.5	133.5	148.5	141.5	161.5	146.5	161.5	182
S	67	72	72	87	80	100	85	100	120.5

YS-RA

Ultra-Compact Closed-Center Hydraulic Cylinder
with Proximity Bracket and Built-in Rotary joint



Application / Benefits

Compact cylinder for work not requiring spindle through
Built-in rotary union for air through

Technical features

Check valve maintains pressure during power outage
Built in rotary joint

SPECIFICATIONS

	YS-11020RA	YS-12021RA	YS-13030RA
Piston Stroke [mm]	20	21	30
Piston Surface Area (Push) [cm ²]	87.6	105.7	131.8
Piston Surface Area (Pull) [cm ²]	84	102	122.5
Piston Force (Push) [kN(kgf)]	28(2855)	39(3977)	47(4793)
Piston Force (Pull) [kN(kgf)]	27(2753)	38(3875)	45(4589)
Max. Operating Pressure [MPa(kgf/cm ²)]	3.5(35.7)	4.0(40.8)	4.0(40.8)
Max. r.p.m. [min ⁻¹]	6000	6000	6000
Moment of inertia [N · m ² (kg · m ²)]	0.157(0.016)	0.274(0.028)	0.284(0.029)
Weight [kg]	8.2	10.2	10.3
Total leakage [ℓ /min]	1.2	1.2	1.2

※ Specifications are subject to change without notice.

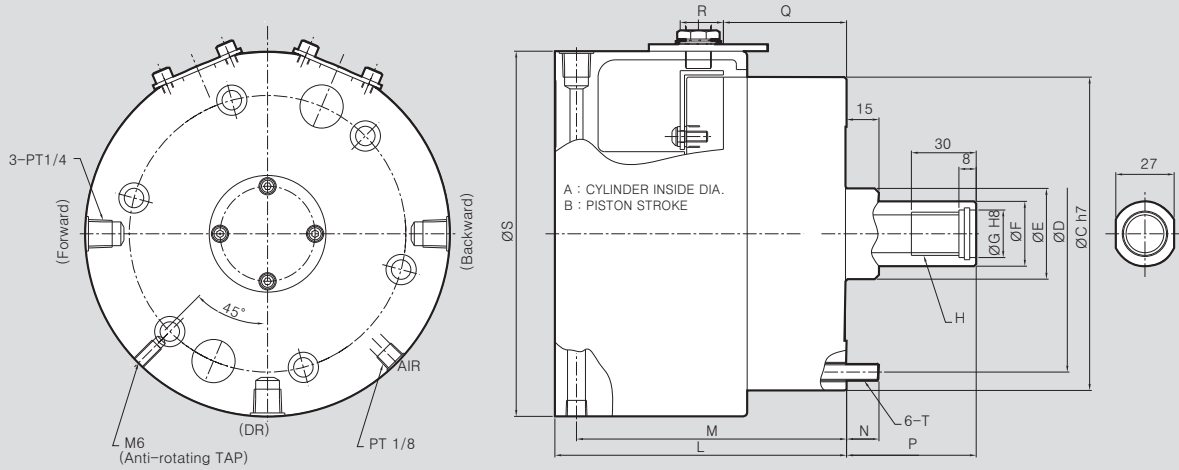

DIMENSIONS

	YS-11020RA	YS-12021RA	YS-13030RA
A	110	120	130
B	20	21	30
ØC	145	168	168
ØD	128	145	150
ØE	42	42	51
ØF	30	30	36
ØG	22	22	26
H	M20x2.5	M20x2.5	M24x3.0
J	30	30	35
K	15	15	15
L	135	135	144
M	125	125	134
N	14	17	17
P max.	60	60	60
P min.	40	39	30
Q max.	77	78	90
Q min.	57	57	66
R	20	20	20
ØS	169	192	192
T	M8x80	M8x80	M10x80

DY Double-Piston Hydraulic Cylinder



Application / Benefits

For 2+2 chucks, face drivers, ejectors and applications requiring dual actuation

Technical features

Double piston for dual actuation

SPECIFICATIONS

	DY-12530		DY-16030	
	Piston A	Piston B	Piston A	Piston B
Piston Dia. [mm]	125	85	160	85
Piston Area [cm ²]	102	46	164	46
Piston Stroke. Max	49	38	60	48
Piston Stroke. Min	34	18	45	18
Max. Operating Pressure [MPa(kgf/cm ²)]	4(40.8)		4(40.8)	
Max. r.p.m. [min ⁻¹]	5000		3000	
Weight [kg]	16.5		24.5	
Moment of inertia [N · m ² (kg · m ²)]	0.441(0.045)		2.94(0.3)	

※ Specifications are subject to change without notice.

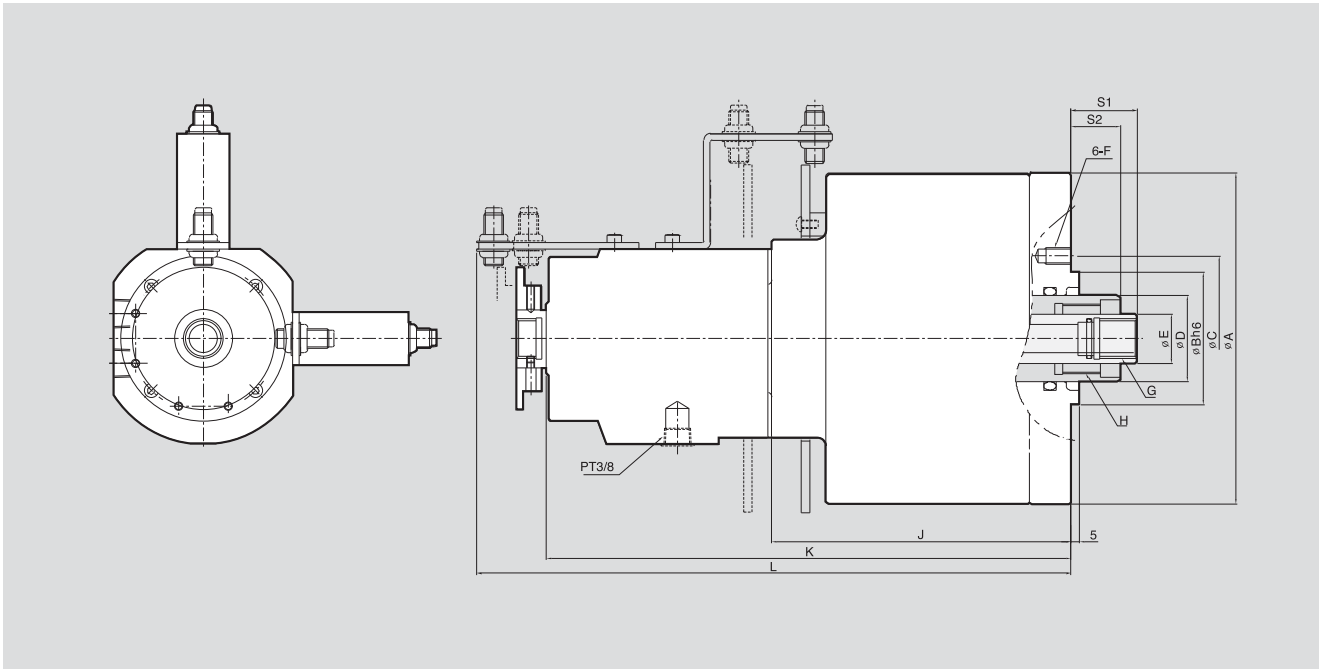

- ※ Piston A : Outer Piston
- ※ Piston B : Inner Piston

DIMENSIONS

	DY-12530	DY-16030
ΦA	160	200
ΦB(h6)	110	125
ΦC	145	100
ΦD	50	52
ΦE	29	30
F	6-M12	6-M10
G	M20x1.5	M24x1.5
H	M42x1.5	M42x1.5
J	178	181
K	299	371
L	341	359



Application / Benefits

For 2+2 chucks, face drivers, ejectors and applications requiring dual actuation

Technical features

Built-in ports for air and coolant through

SPECIFICATIONS

	DYV-21560	
	Piston A	Piston B
Piston Stroke	60	60
Piston Force (Push) [kN(kgf)]	16.9(1724)	11.8(1206)
Piston Force (Pull) [kN(kgf)]	13.9(1420)	11.1(1130)
Piston Surface Area (Push) [cm ²]	363	254
Piston Surface Area (Pull) [cm ²]	301	238
Max. Operating Pressure [MPa(kgf/cm ²)]	5.1(50)	
Max. r.p.m. [min ⁻¹]	3200	
Weight [kg]	92	
Moment of inertia [N·m ² (kgf·m ²)]	0.89	

- ※ Specifications are subject to change without notice.
- ※ Piston Force : Hydraulic 4.0MPa (40.8 kgf/cm²)
- ※ Total leakage pressure : 3.0MPa(30.6 kgf/cm²) at 50° C
- ※ Samchully Machinery Co., Ltd. is no longer an OEM manufacturer for Kitagawa Iron Works Co., Ltd

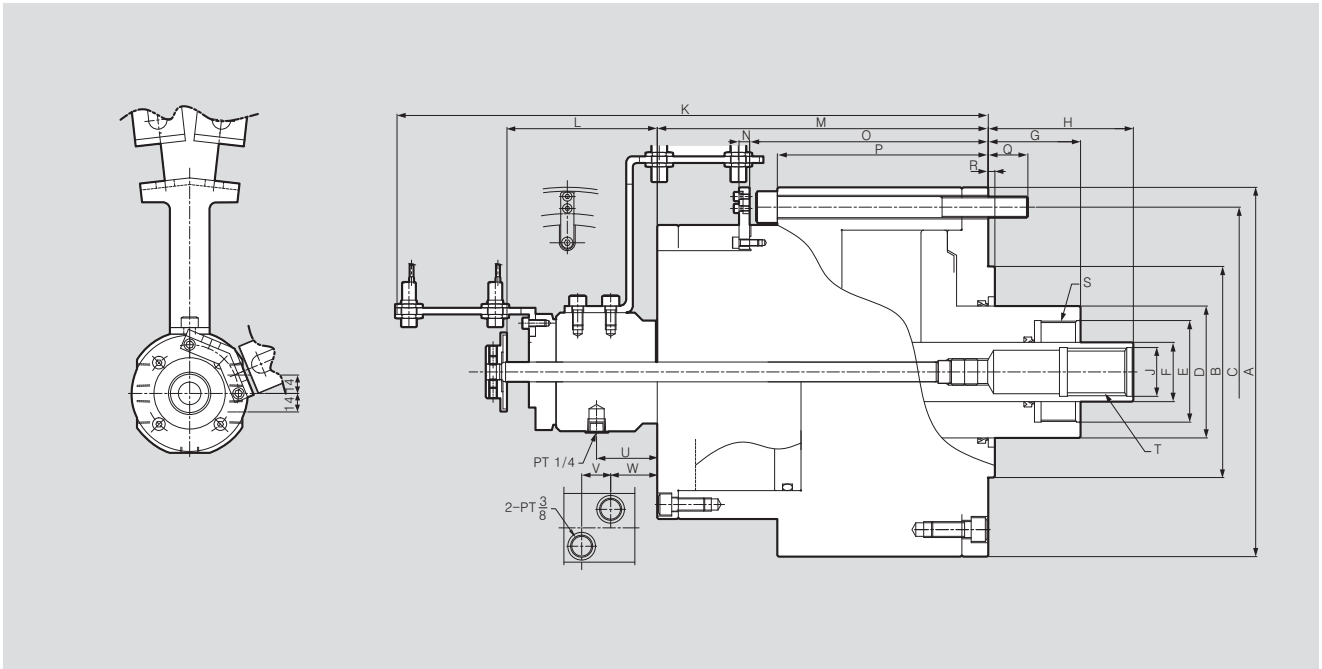

- ※ Piston A : Outer Piston
- ※ Piston B : Inner Piston

DIMENSIONS

DYV-21560			
ΦA	280	L	114
ΦB	160	M	251
ΦC	250	N	8
ΦD	100	O	181
ΦE	77	P	160
ΦF	45	Q	30
G max.	70	R	5
G min.	10	S	M75x2.0
H max.	110	T	M36x4.0
H min.	50	U	46
ΦJ	37	V	22
K	448.3	W	35.3

AY-R Closed-Center Pneumatic Cylinder



Application / Benefits

Closed-Center Pneumatic Cylinder
Suitable for cutting thin material

SPECIFICATIONS

	AY-1005R	AY-1315R	AY-1720R	AY-2225R	AY-2730R
Piston Stroke [mm]	5	15	20	25	30
Piston Surface Area (Push) [cm ²]	78.5	131	225	378	570.4
Piston Surface Area (Pull) [cm ²]	73.6	128	220.1	371.1	560.8
Piston Force (Push) [kN(kgf)]	5.4(552)	7.7(786)	13.23(1350)	22.2(2268)	33.5(3422)
Piston Force (Pull) [kN(kgf)]	5.1(518)	7.5(770)	12.9(1320)	21.8(2226)	33.0(3364)
Max. Operating Pressure [MPa(kgf/cm ²)]	8(0.82)	8(0.82)	8(0.82)	8(0.82)	8(0.82)
Max. r.p.m. [min ⁻¹]	5000	5000	5000	4000	3000
Weight [kg]	4.1	5.2	8.3	13.3	18.7
Moment of inertia [N · m ² (kg · m ²)]	0.686(0.07)	0.686(0.07)	1.078(0.11)	2.450(0.25)	7.350(0.75)

※ Maximum turning speed is based upon actual measurement.

※ Specifications are subject to change without notice.

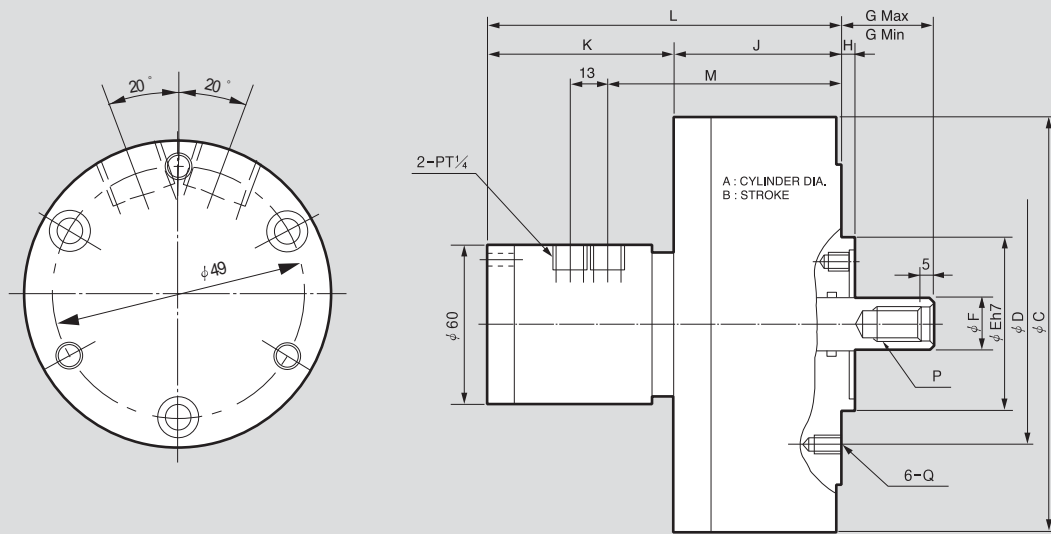

DIMENSIONS

	AY-1005R	AY-1315R	AY-1720R	AY-2225R	AY-2730R
A	100	130	170	220	270
B	5	15	20	25	30
ΦC	128	156	200	255	305
ΦD	90	90	100	130	130
ΦE(h7)	65	65	80	110	110
ΦF	20	20	25	30	35
G max.	30	35	65	71	76
G min.	25	20	45	46	46
H	5	5	5	5	5
J	53	63	82	93	103
K	70	70	70	70	74.5
L	123	133	152	163	177.5
M	79	89	108	119	133.5
N	M5	M6	M7	M8	M9
Q	M6x11	M6x11	M10x16	M12x20	M12x20
P	M12x22	M12x22	M16x30	M20x35	M24x40



MANUAL CHUCK

During our early days as an oem manufacturer of manual chucks, we have inherited and improvised on the commitment to making high quality products. Our manual chucks are proud symbols of steadfast dedication to precision and performance.



SC

Standard Scroll
Chuck(Hard Jaws)

132 P



MU

Manual Chuck

142 P



FSC

Standard Front
Mounting Scroll
Chuck(Hard Jaws)

134 P



IC

Independent
Chuck(Hard Jaws)

144 P



TC

Standard Scroll
Chuck(Soft & Hard
Top Jaws)

135 P



IC Mega Bore

Independent
Chuck(Hard Jaws)

146 P



FTC

Front Mounting
Scroll Chuck(Soft &
Hard Top Jaws)

136 P



ST

2-Jaw Scroll Chuck
(Soft Top Jaws)

138 P



SF

4-Jaw Scroll Chuck
(Hard Jaws)

139 P



SCS

6-Jaw Scroll Chuck
(Hard Jaws)

140 P



SL

Standard Slotter
Chuck(Hard Jaws)

141 P

SC Standard Scroll Chuck (Hard Jaws)

Thru Hole Range : $\varnothing 16 \sim \varnothing 57$
Clamping Range : $\varnothing 2 \sim \varnothing 180$

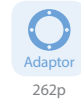

Application / Benefits

For work requiring through hole

Technical features

Reversible one-piece hard jaws

Rear mounting only

Self-centering jaws manually opened by t-handle

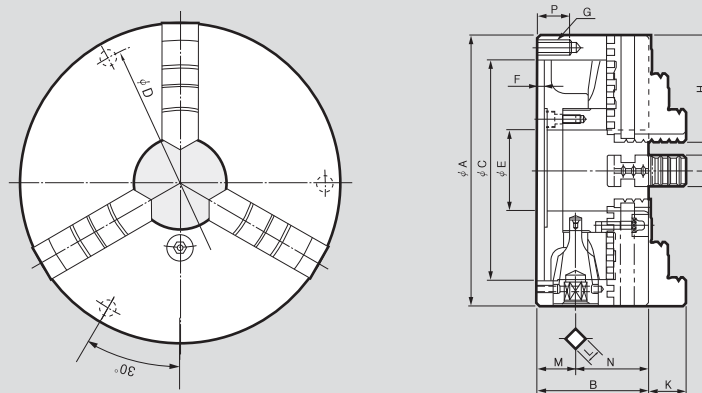

DIMENSIONS

	SC-85(3")	SC-110(4")	SC-130(5")	SC-165(6")	SC-190(7")
ΦA	85	110	130	167	192
B	44.1	58	60	65	75
ΦC(H6)	60	80	100	130	155
ΦD	73	95	115	147	172
ΦE	16	24	34	45	57
F	3.5	4.5	4.5	5	5
G	3-M6	3-M8	3-M8	3-M10	3-M10
H	35	44	50	65	75
J	11	14	16	19	22
K	14.6	20.0	20.1	25.07	30.06
L	7	8	8	10	11
M	17	24.5	22.5	24	27.5
N	27.1	32.35	37	41	47.5
P	13	16	16	20	20

SPECIFICATIONS

	SC-85 (3")	SC-110 (4")	SC-130 (5")	SC-165 (6")	SC-190 (7")
Max. Static Gripping Force [kN(kgf)]	9(918)	12(1224)	15(1530)	31(3161)	31(3161)
Clamping Range External [φmm]	2~70	3~94	3~110	3~160	4~180
Clamping Range Internal [φmm]	24~64	29~84	33~100	48~150	56~170
Handle Torque [N · m(kgf · m)]	29.4(3.0)	44.1(4.1)	63.7(6.5)	88.3(9.0)	107.9(11.0)
Max. r.p.m. [min ⁻¹]	2500	2500	2500	4000	3500
Weight [kg]	1.5	3.1	4.4	11.4	12.2
Moment of inertia [N · m ² (kg · m ²)]	0.05(0.005)	0.17(0.017)	0.35(0.036)	1.18(0.12)	2.35(0.24)

SC Standard Scroll Chuck (Hard Jaws)

Thru Hole Range : $\varnothing 75 \sim \varnothing 130$
Clamping Range : $\varnothing 5 \sim \varnothing 346$

 Adaptor
262p

 H/S Jaw
261p



Application / Benefits

For work requiring through hole

Technical features

Reversible one-piece hard jaws

Rear mounting only

Self-centering jaws manually opened by t-handle

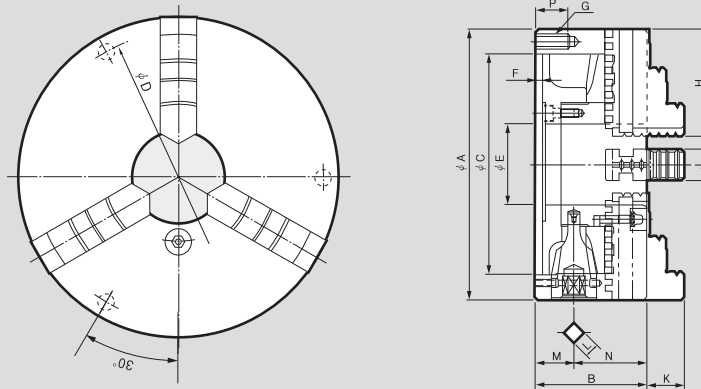

DIMENSIONS

	SC-230(9")	SC-273(10")	SC-310(12")	SC-355(14")	SC-405(16")
$\varnothing A$	232	273	310	355	405
B	84	86	96	110	114.5
$\varnothing C(H6)$	190	230	260	300	345
$\varnothing D$	210	250	285	328	375
$\varnothing E$	75	89	100	105	130
F	6	6	7	8	8
G	3-M12	3-M12	3-M12	6-M12	6-M12
H	85	98	110	133	133
J	24	28	30	35	35
K	35.04	40.02	45.08	62.98	63
L	12	12	14	14	15
M	29.5	31.5	31.5	42.4	43
N	54.5	54.5	64.5	67.6	71.5
P	25	25	25	36	36

SPECIFICATIONS

	SC-230 (9")	SC-273 (10")	SC-310 (12")	SC-355 (14")	SC-405 (16")
Max. Static Gripping Force [kN(kgf)]	37(3773)	46(4691)	55(5608)	40.5(4130)	45(4589)
Clamping Range External [\varnothing mm]	5~200	5~260	10~300	25~315	25~346
Clamping Range Internal [\varnothing mm]	62~210	70~250	86~290	107~290	113~324
Handle Torque [N · m(kgf · m)]	147(15.0)	176.5(18.0)	206(21.0)	225.6(23.0)	245(25.0)
Max. r.p.m. [min^{-1}]	2900	2500	2200	1500	1500
Weight [kg]	21.2	28	41	54	74
Moment of inertia [N · m ² (kg · m ²)]	6.27(0.64)	9.90(1.01)	23.0(2.35)	37.2(3.8)	67.6(6.9)

* Maximum turning speed is based upon actual measurement.

FSC Standard Front-Mounting Scroll Chuck (Hard Jaws)

Thru Hole Range : $\varnothing 34 \sim \varnothing 100$
Clamping Range : $\varnothing 3 \sim \varnothing 300$



Application / Benefits

For work requiring through hole
Front mounting holes for convenient installation on lathes and spindles

Technical features

Reversible one-piece hard jaws
Self-centering jaws manually opened by t-handle

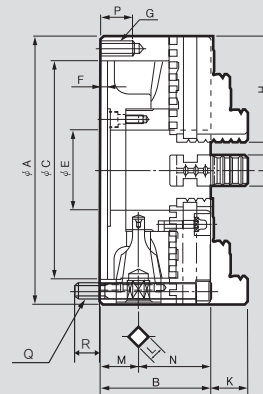
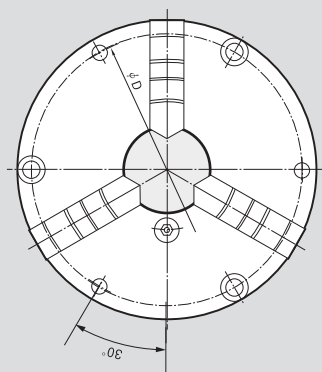

DIMENSIONS

	FSC-130(5")	FSC-165(6")	FSC-190(7")	FSC-230(9")	FSC-273(10")	FSC-310(12")
$\varnothing A$	130	167	192	232	273	310
B	60	65	75	84	86	96
$\varnothing C(H6)$	100	130	155	190	230	260
$\varnothing D$	115	147	172	210	250	285
$\varnothing E$	34	45	57	75	89	100
F	4.5	5	5	6	6	7
G	3-M8	3-M10	3-M10	3-M12	3-M12	3-M12
H	50	65	75	87	98	110
J	16	19	22	24	28	30
K	19.6	25.07	30.06	35.04	40.02	45.08
L	8	10	11	12	12	14
M	22.5	24	27.5	29.5	31.5	31.5
N	37	41	47.5	54.5	54.5	64.5
P	16	20	20	25	25	25
Q	3-M8x65	3-M10x70	3-M10x85	3-M12x95	3-M12x95	3-M12x110
R	14	16	17	24	20	27

SPECIFICATIONS

	FSC-130(5")	FSC-165(6")	FSC-190(7")	FSC-230(9")	FSC-273(10")	FSC-310(12")
Max. Static Gripping Force [kN(kgf)]	15(1530)	31(3161)	31(3161)	37(3773)	46(4691)	55(5608)
Clamping Range External [\varnothing mm]	3~110	3~160	4~180	5~220	5~260	10~300
Clamping Range Internal [\varnothing mm]	3~100	48~150	56~170	62~210	70~250	86~290
Handle Torque [N · m(kgf · m)]	63.7(6.5)	88.3(9.0)	107.9(11.0)	147(15.0)	176.5(18.0)	206(21.0)
Max. r.p.m. [min^{-1}]	2500	4000	3500	2900	2500	2200
Weight [kg]	4.4	11.4	12	21.2	28	41
Moment of inertia [N · m ² (kg · m ²)]	0.35(0.036)	1.18(0.12)	2.35(0.24)	6.27(0.64)	9.90(1.01)	23.0(2.35)

※ Specifications are subject to change without notice.

TC Standard Scroll Chuck (Soft and Hard top Jaws)

Thru Hole Range : $\varnothing 57 \sim \varnothing 100$
Clamping Range : $\varnothing 4 \sim \varnothing 300$



Application / Benefits

For work requiring through hole

Technical features

- Two-piece, reversible base jaw and top hard jaws (soft top jaws also included)
- Rear mounting only
- Self-centering jaws manually opened and closed by t-handle

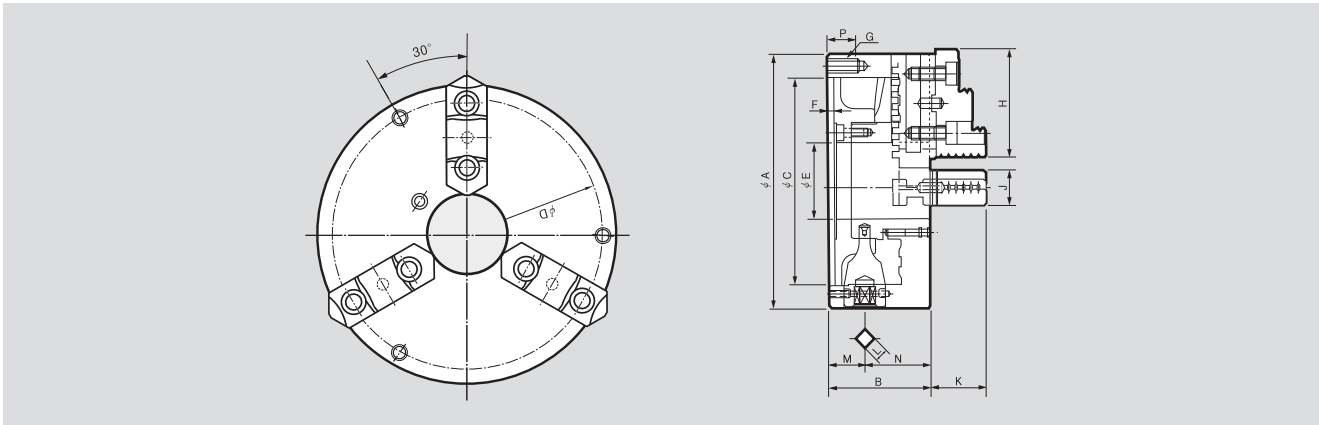

DIMENSIONS

	TC-190(7")	TC-230(9")	TC-273(10")	TC-310(12")
$\varnothing A$	192	232	273	310
B	78.7	83.7	88	96
$\varnothing C$	155	190	230	260
$\varnothing D$	172	210	250	285
$\varnothing E$	57	75	89	100
F	5	6	6	7
G	3-M10	3-M12	3-M12	3-M12
H	80.5	90.5	103.5	115.5
J	28	32	35	40
K	42.8	53.8	57.82	56.08
L	11	12	12	14
M	27.5	29.5	31.5	31.5
N	51.2	54.2	56.5	64.5
P	20	25	25	25
Mounting bolt	3-M10	3-M12	3-M12	3-M12

SPECIFICATIONS

	TC-190(7")	TC-230(9")	TC-273(10")	TC-310(12")
Max. Static Gripping Force [kN(kgf)]	31(3161)	37(3773)	46(4691)	55(5608)
Clamping Range External [ϕ mm]	4~180	5~220	5~260	10~300
Clamping Range Internal [ϕ mm]	56~170	62~210	70~250	86~290
Handle Torque [N · m(kgf · m)]	107.9(11.0)	147(15.0)	173.5(18.0)	206(21.0)
Max. r.p.m. [min^{-1}]	6500	2900	2500	2200
Weight [kg]	12.2	21.2	28	41
Moment of inertia [N · m ² (kg · m ²)]	2.35(0.24)	6.24(0.64)	9.90(1.01)	23.0(2.35)

※ Maximum turning speed is based upon actual measurement.

FTC Front-Mounting Scroll Chuck (Soft and Hard top Jaws)

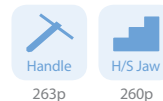

Application / Benefits

For work requiring through hole
Front mounting holes for convenient installation on lathes and spindles

Technical features

Two-piece, reversible base jaw and top hard jaws (soft top jaws also included)
Self-centering jaws manually opened and closed by t-handle

SPECIFICATIONS

	FTC-165	FTC-190(7")	FTC-230(9")	FTC-273(10")	FTC-310(12")
Max. Static Gripping Force [kN(kgf)]	31(3161)	31(3161)	37(3773)	46(4691)	55(5608)
Clamping Range External [ϕ mm]	3~160	4~180	5~220	5~260	10~300
Clamping Range Internal [ϕ mm]	55~150	56~170	62~210	70~250	86~290
Handle Torque [N · m(kgf · m)]	88(9.0)	107.9(11.0)	147(15.0)	176.5(18.0)	206(21.0)
Max. r.p.m. [min^{-1}]	4000	3500	2900	2500	2200
Weight [kg]	9	12.2	21.2	28	41
Moment of inertia [N · m ² (kg · m ²)]	0.033	0.62(0.063)	1.61(0.163)	2.63(0.265)	5.85(0.588)

	FTC-460(18")	FTC-535(21")	FTC-610(24")	FTC-810(32")	FTC-1000(40")
Max. Static Gripping Force [kN(kgf)]	65(6650)	73(7400)	80(8200)	110(11216)	110(11216)
Clamping Range External [ϕ mm]	40~410	45~481	130~576	270~810	340~990
Clamping Range Internal [ϕ mm]	152~436	155~499	235~592	390~800	450~940
Handle Torque [N · m(kgf · m)]	255.0(26)	313.9(32)	372.7(38)	588(60)	588(60)
Max. r.p.m. [min^{-1}]	1200	950	850	650	470
Weight [kg]	106	182	238	480	780
Moment of inertia [N · m ² (kg · m ²)]	124(12.6)	287(29.3)	488(49.8)	598(61)	598(61)

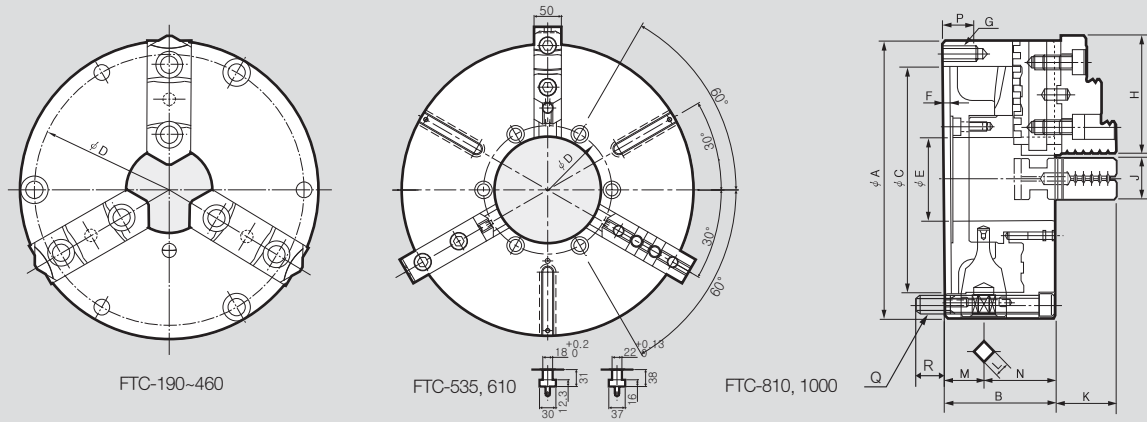

DIMENSIONS

	FTC-165	FTC-190(7")	FTC-230(9")	FTC-273(10")	FTC-310(12")	FTC-460(18")	FTC-535(21")	FTC-610B(24")	FTC-810(32")	FTC-1000(40")
ΦA	167	192	232	273	310	460	535	610	810	1000
B	69	78.7	83.7	88	96	114	143	143	180	196
$\Phi C(H6)$	130	155	190	230	260	400	270	380	520	910
ΦD	147	172	210	250	285	425	235	315	425	510
ΦE	47	57	75	89	100	190	195	275	375	580
F	5	5	6	6	7	8	12	14	16	16
G	3-M10	3-M10	3-M12	3-M12	3-M12	-	-	-	-	-
H	67	80.5	90.5	103.5	115.5	140(130)	150(130)	130	248	286
J	26	28	32	35	40	50	50	50	70	70
K	38.5	42.8	53.8	57.82	56.08	80	82	82	95	95
L	10	11	12	12	14	17	22	22	22	22
M	24	27.5	29.5	31.5	31.5	38.2	57.5	57.5	64	69.5
N	45	51.2	54.2	56.5	64.5	76	85.5	85.5	116	126.5
P	20	20	25	25	25	-	-	-	-	-
Q	3-M10x75	3-M10x90	3-M12x95	3-M12x95	3-M12x110	3-M16x125	3-M20x140	3-M20x140	3-M24x140	3-M24x190
R	17	22	24	20	27	29	32	33	32	35

ST 2Jaw Scroll Chuck (Soft top Jaws)

Thru Hole Range : $\varnothing 57 \sim \varnothing 100$
Clamping Range : $\varnothing 4 \sim \varnothing 300$

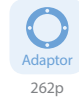

Application / Benefits

For square or rectangular requiring through hole

Technical features

Two-piece base and soft top jaws

Rear mounting only

Self-centering jaws manually opened and closed by t-handle

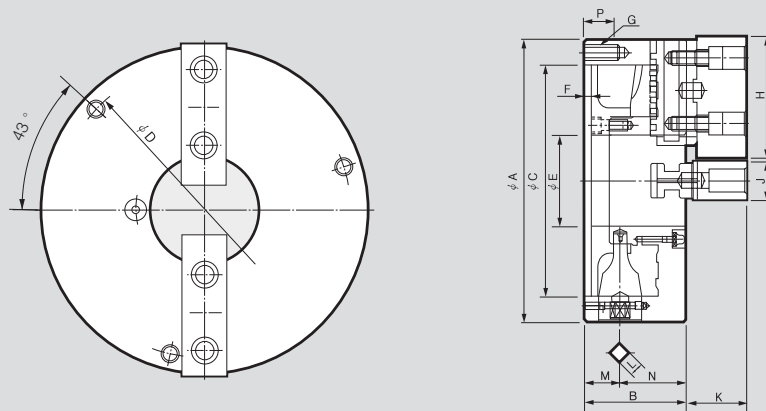

DIMENSIONS

	ST-190(7")	ST-230(9")	ST-273(10")	ST-310(12")
$\varnothing A$	192	232	273	310
B	78.7	83.7	88	96
$\varnothing C(H6)$	155	190	230	260
$\varnothing D$	172	210	250	285
$\varnothing E$	57	75	89	100
F	5	6	6	7
G	3-M10	3-M12	3-M12	3-M12
H	88	100	110	125
J	32	32	35	40
K	44.8	49.8	54.32	50.58
L	11	12	12	14
M	27.5	29.5	31.5	31.5
N	51.2	54.2	56.5	64.5
P	20	25	25	25

SPECIFICATIONS

	ST-190(7")	ST-230(9")	ST-273(10")	ST-310(12")
Max. Static Gripping Force [kN(kgf)]	20.7(2110)	24.7(2518)	46(4691)	55(5608)
Clamping Range External [ϕ mm]	4~180	5~220	5~260	10~300
Clamping Range Internal [ϕ mm]	62~170	70~210	70~250	86~290
Handle Torque [N · m(kgf · m)]	73.5(7.5)	98(10.0)	176.5(18.0)	206(21.0)
Max. r.p.m. [min ⁻¹]	3500	2900	2500	2200
Weight [kg]	12.6	21.4	28	41
Moment of inertia [N · m ² (kg · m ²)]	2.55(0.26)	6.27(0.64)	9.90(1.01)	23.0(2.35)

SF 4-Jaw Scroll Chuck (Hard Jaws)

Thru Hole Range : $\varnothing 57 \sim \varnothing 100$
Clamping Range : $\varnothing 4 \sim \varnothing 300$

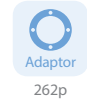

Application / Benefits

For square work requiring through hole

Technical features

Rear mounting only

One-piece reversible, hard jaws

Self-centering jaws manually opened and closed by t-handle

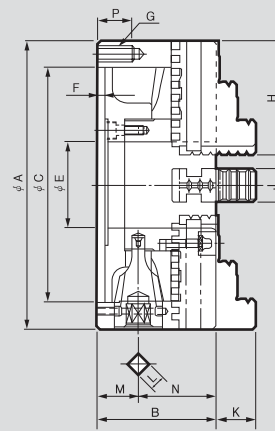
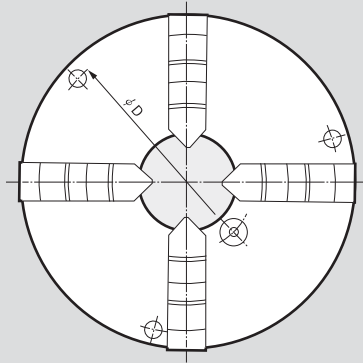

DIMENSIONS

	SF-190(7")	SF-230(9")	SF-273(10")	SF-310(12")	SF-405(16")
$\varnothing A$	192	232	273	310	405
B	75	84	86	96	114.5
$\varnothing C(H6)$	155	190	230	260	345
$\varnothing D$	172	210	250	285	375
$\varnothing E$	57	75	89	100	130
F	5	6	6	7	8
G	3-M10	3-M12	3-M12	3-M12	6-M12
H	75	85	98	110	133
J	22	24	28	30	35
K	30.06	35.04	40.02	45.08	63
L	11	12	12	14	15
M	27.5	29.5	31.5	31.5	42
N	47.5	54.5	54.5	64.5	72.5
P	20	25	25	25	36

SPECIFICATIONS

	SF-190(7")	SF-230(9")	SF-273(10")	SF-310(12")	SF-405(16")
Max. Static Gripping Force [kN(kgf)]	31(3161)	37(3773)	46(4691)	55(5608)	
Clamping Range External [ϕ mm]	4~180	5~220	5~260	10~300	
Clamping Range Internal [ϕ mm]	56~170	62~210	70~250	86~290	
Handle Torque [N · m(kgf · m)]	107.9(11.0)	147(15.0)	176.5(18.0)	206(21.0)	
Max. r.p.m. [min^{-1}]	3500	2900	2500	2200	
Weight [kg]	12.5	21.5	28	41	
Moment of inertia [N · $\text{m}^2(\text{kg} \cdot \text{m}^2)$]	2.45(0.25)	6.37(0.65)	9.90(1.01)	23.0(2.35)	

※ Maximum turning speed is based upon actual measurement.

SCS 6-Jaw Scroll Chuck (Hard Jaws)

Thru Hole Range : $\varnothing 75 \sim \varnothing 100$
Clamping Range : $\varnothing 5 \sim \varnothing 300$

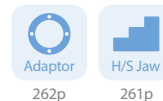

Application / Benefits

For work prone to deformity requiring through hole
Minimizes deformation

Technical features

Rear mounting only
One-piece reversible, hard jaws
Self-centering jaws manually opened and closed by t-handle

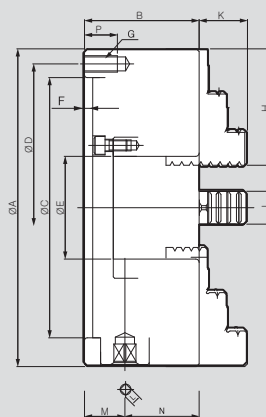
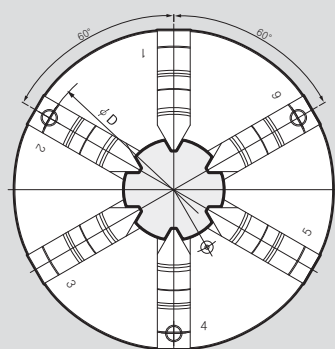

DIMENSIONS

	SCS-230(9")	SCS-273(10")	SCS-310(12")
$\varnothing A$	232	273	310
B	84	86	96
$\varnothing C(H6)$	190	230	260
$\varnothing D$	210	250	285
$\varnothing E$	75	89	100
F	6	6	7
G	3-M12	3-M12	3-M12
H	85	98	110
J	24	28	30
K	35.04	40.02	45.08
L	12	12	14
M	29.5	31.5	31.5
N	54.5	54.5	64.5
P	25	25	25

SPECIFICATIONS

	SCS-230 (9")	SCS-273 (10")	SCS-310 (12")
Max. Static Gripping Force [kN(kgf)]	37(3773)	46(4691)	55(5608)
Clamping Range External [ϕ mm]	5~200	5~260	10~300
Clamping Range Internal [ϕ mm]	62~210	70~250	86~290
Handle Torque [N · m(kgf · m)]	147(15.0)	176.5(18.0)	206(21.0)
Max. r.p.m. [min^{-1}]	2900	2500	2200
Weight [kg]	24	32	45
Moment of inertia [N · m ² (kg · m ²)]	6.27(0.64)	9.90(1.01)	23.0(2.35)

※ Maximum turning speed is based upon actual measurement.

SL Standard Slotter Chuck (Hard Jaws)

Thru Hole Range : $\varnothing 60 \sim \varnothing 100$
Clamping Range : $\varnothing 4 \sim \varnothing 266$

 Handle
263p

 H/S Jaw
261p



Application / Benefits

Low-profile and compact
Ideal for machining centers

Technical features

Angled t-handle slot
One-piece, reversible hard jaws

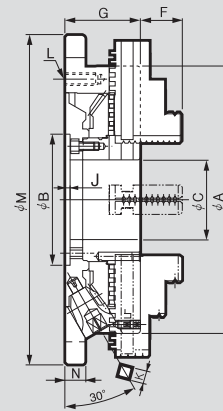
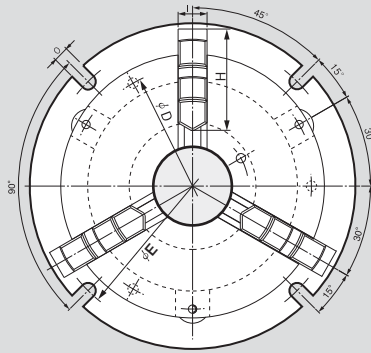

DIMENSIONS

	SL-08	SL-10	SL-12
ΦA	215	255	305
ΦB(HC6)	110	125	160
ΦC	60	76	100
ΦD	190.5	230	280
ΦE	240	286	340
F	35.04	40.02	45.05
G	64	72	76
H	85	98	110
I	25	28	30
J	4	4.5	5
K	11	12	14
L	M10	M12	M12
M	266	315	370
N	17	20	22
O	13	15	17

SPECIFICATIONS

	SL-08	SL-10	SL-12
Max. Static Gripping Force [kN(kgf)]	37(3,800)	46(4,700)	55(5,620)
Clamping Range External [φmm]	4~182	4~220	5~266
Clamping Range Internal [φmm]	58~174	68~212	80~263
Handle Torque [N · m(kgf · m)]	117.7(13)	176.5(18)	196.2(20)
Weight [kg]	17.6	27.7	40

※ Maximum turning speed is based upon actual measurement.



Application / Benefits

Easy to operate scroll chuck with stepped jaws.

SPECIFICATIONS

	MU-32	MU-40	MU-50	MU-63
Box Jaw Stroke [mm]	60	60	50	50
Max. Static Gripping Force. [kN(kgf)]	-	-	-	-
Clamping Range. Max [mm]	681	885	1050	1450
Clamping Range. Min [mm]	112	316	281	321
Max. r.p.m. [min^{-1}]	650	500	400	360
Weight [kg]	350	800	1250	1600
Moment of inertia [$\text{N} \cdot \text{m}^2(\text{kg} \cdot \text{m}^2)$]	-	-	-	-

- ※ Maximum turning speed is based upon actual measurement.
- ※ T-Slot can be changed at the request.

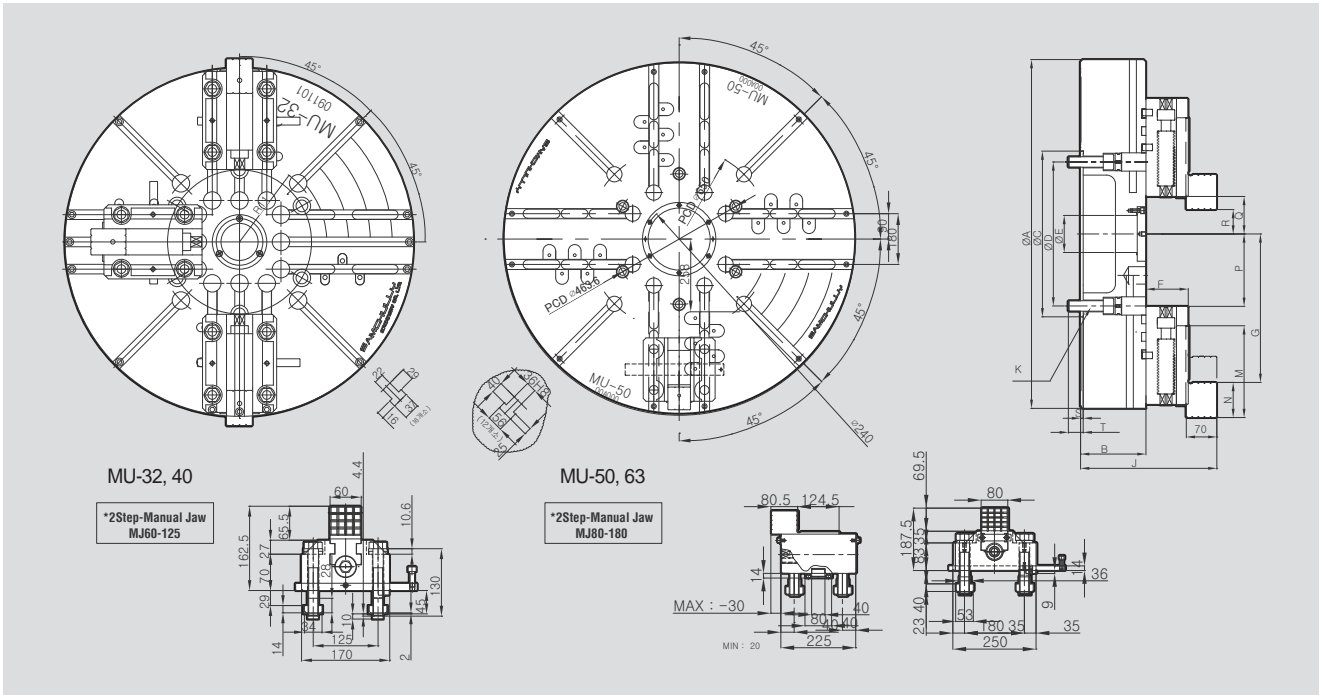

DIMENSIONS

	MU-32	MU-40	MU-50	MU-63
ΦA	800	1000	1250	1600
ΦB(76)	150	150	180	240
ΦC	380	520	520	1020
ΦD	330.2	463.6	463.6	956
ΦE	85	178	220	320
F	99.5	99.5	124.5	124.5
G max	340.5	442.5	525	725
J	312.5	312.5	367.5	427.5
K	6-M24x80L	6-M24x90L	6-M24x100L	12-M24x140L
M	210.5	210.5	205	205
N	80.5	80.5	80.5	80.5
P	166	268	345	365
Q	86	188	170.5	190.5
R min	56	158	140.5	160.5
S	6	8	8	8
T	34	41	54	38

IC Independent Chuck (Hard Jaws) (200mm - 400mm)

Thru Hole Range : $\varnothing 50 \sim \varnothing 90$
Clamping Range : $\varnothing 75 \sim \varnothing 360$

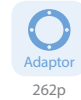

Application / Benefits

Independently jaws suitable for irregular work
Chucks 10 inches and larger have t-slots on body for added versatility

Technical features

One-piece, reversible hard jaws

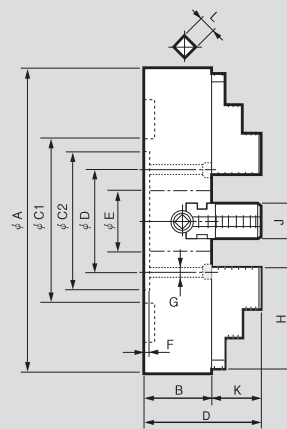
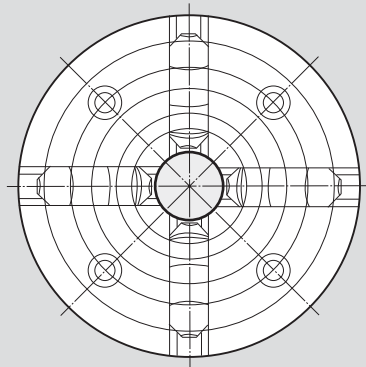

DIMENSIONS

	IC-08	IC-10	IC-12	IC-14	IC-16
A	200	250	300	350	400
B	75	80	90	90	100
C1	200	165	186	210	130
C2	175	150	170	190	210
D	155	125	140	160	180
E	50	55	65	75	90
F	6	6	6	8	8
G	M12	M12	M12	M12	M16
H	75	90	100	110	120
J	30	30	35	35	40
K	30	35	40	45	50
L	10	10	12	12	14

SPECIFICATIONS

	IC-08	IC-10	IC-12	IC-14	IC-16
Max. Static Gripping Force [kN(kgf)]	1000	1400	1600	1700	2000
Clamping Range External [ϕ mm]	75	95	125	155	190
Clamping Range Internal [ϕ mm]	185	220	265	310	360
Max. r.p.m. [min^{-1}]	1600	1600	1400	1400	1200
Weight [kg]	14.8	21	29.5	40	56.5
Moment of inertia [$\text{N} \cdot \text{m}^2(\text{kg} \cdot \text{m}^2)$]	0.3	0.6	1.4	2.9	4.5

※ Specifications are subject to change without notice.

IC Independent Chuck (Hard Jaws) (450mm - 813mm)

Thru Hole Range : $\varnothing 100 \sim \varnothing 140$
Clamping Range : $\varnothing 220 \sim \varnothing 750$



Application / Benefits

Independently moving jaws suitable for irregular work
Chucks 10 inches and larger have t-slots on body for added versatility

Technical features

One-piece, reversible hard jaws

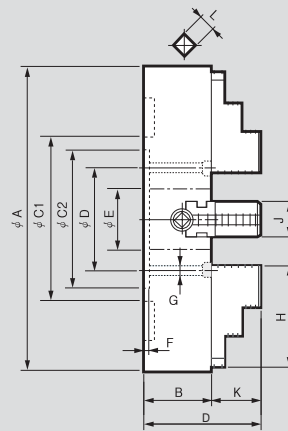
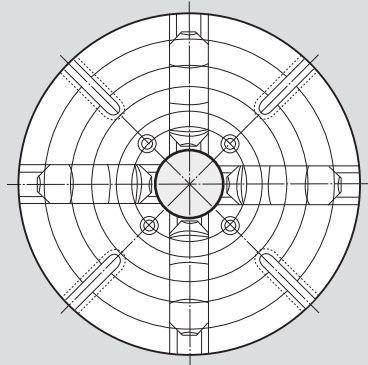

DIMENSIONS

	IC-18	IC-20	IC-24	IC-28	IC-32
A	450	500	600	710	813
B	105	110	120	120	120
C1	230	272	330	382	440
C2	230	250	300	350	400
D	200	220	260	300	350
E	100	110	120	130	140
F	8	8	10	12	12
G	M16	M16	M20	M20	M20
H	130	140	160	190	190
J	40	45	50	55	55
K	55	60	70	85	85
L	14	14	14	14	19

SPECIFICATIONS

	IC-18	IC-20	IC-24	IC-28	IC-32
Max. Static Gripping Force [kN(kgf)]	2000	2200	2300	2396	2447
Clamping Range External [ϕ mm]	220	250	320	385	485
Clamping Range Internal [ϕ mm]	405	450	550	650	750
Max. r.p.m. [min^{-1}]	1200	900	900	900	600
Weight [kg]	70	90	150	247	357
Moment of inertia [$\text{N} \cdot \text{m}^2(\text{kg} \cdot \text{m}^2)$]	7	11.8	25.3	58	103

- ※ Maximum turning speed is based upon actual measurement.
- ※ Specifications are subject to change without notice.

IC Independent Chuck (Hard Jaws) (500mm - 600mm) **MEGA BORE**

Thru Hole Range : $\varnothing 180 \sim \varnothing 275$
Clamping Range : $\varnothing 450 \sim \varnothing 550$



Application / Benefits

Durable with large bore ideal for oil-field related work such as pipe
Independently moving jaws

Technical features

Adapters enable mounting on various spindle sizes
Two-piece, reversible base and hard top jaw (also includes soft jaws)

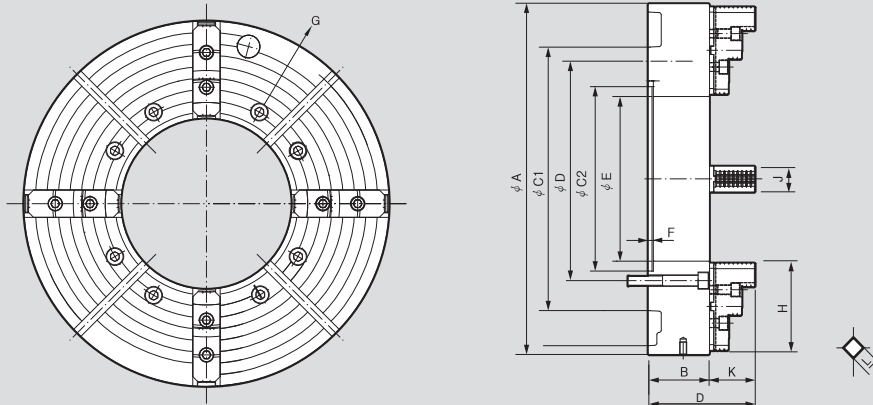

DIMENSIONS

	IC-2018	IC-2023	IC-2423	IC-2427
ΦA	500	500	600	600
B	110	110	140	140
ΦC2	260	300	420	420
ΦD	230	270	463.6	463.6
ΦE	180	230	230	275
F	-	8	10	10
G	M16	M16	M24	M24
H	135	140	200	200
J	45	45	60	60
K	83.45	83.45	104.15	104.15
L	14	14	24	24

SPECIFICATIONS

	IC-2018	IC-2023	IC-2423	IC-2427
Max. Static Gripping Force [kN(kgf)]	27.4(2800)	27.4(2800)	28.5(2904)	30(3056)
Clamping Range External [φmm]	460	460	550	550
Clamping Range Internal [φmm]	450	450	530	550
Max. r.p.m. [min ⁻¹]	800	800	800	800
Weight [kg]	180	170	350	340
Moment of inertia [N · m ² (kg · m ²)]	54.9(5.6)	51.41(5.3)	61.74(6.3)	61.74(6.3)

※ Soft & Hard jaws are basic components.
※ Specifications are subject to change without notice.

IC Independent Chuck (Hard Jaws)

(600mm - 1000mm) **MEGA BORE**

Thru Hole Range : $\varnothing 320 \sim \varnothing 560$
Clamping Range : $\varnothing 550 \sim \varnothing 1000$



Application / Benefits

Durable with large bore ideal for oil-field related work such as pipe
Independently moving jaws

Technical features

Adapters enable mounting on various spindle sizes
Two-piece, reversible base and hard top jaw (also includes soft jaws)

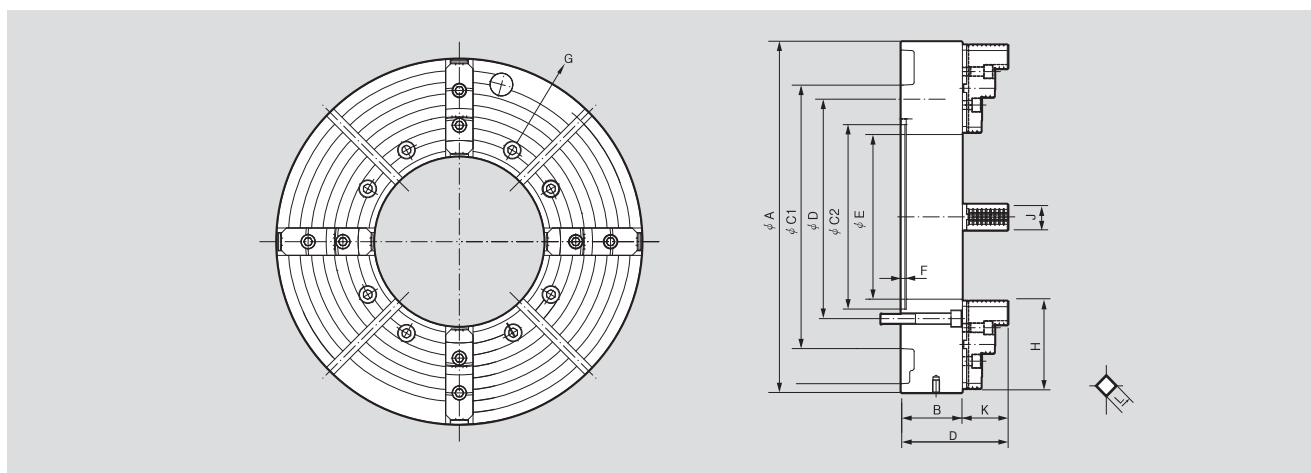

DIMENSIONS

	IC-2432	IC-3232	IC-3237	IC-4056
$\varnothing A$	600	800	800	1000
B	140	140	140	160
$\varnothing C2$	420	420	420	650
$\varnothing D$	463.6	463.6	463.6	700
$\varnothing E$	320	325	375	560
F	10	12	12	10
G	M24	M24	M24	M22
H	200	200	200	200
J	60	60	60	60
K	104.15	104.15	104.15	104.15
L	24	24	24	-

SPECIFICATIONS

	IC-2432	IC-3232	IC-3237	IC-4056
Max. Static Gripping Force [kN(kgf)]	30(3056)	32.4(3300)	32.4(3300)	36(3700)
Clamping Range External [\varnothing mm]	550	750	750	920
Clamping Range Internal [\varnothing mm]	550	730	730	840
Max. r.p.m. [min^{-1}]	800	600	600	480
Weight [kg]	340	463	490	660
Moment of inertia [$\text{N} \cdot \text{m}^2(\text{kg} \cdot \text{m}^2)$]	61.74(6.3)	382(39)	382(39)	-

- ※ Soft & Hard jaws are basic components.
- ※ Specifications are subject to change without notice.



STEADY REST

Samchully steady rests are designed and built to last.

With their robust arms and rollers, the steadyrest is able provide the support with minimal maintainence and setup.



STA

Self-Centering
Steady Rest

150 P



STRA

Wide-Opening
Self-Centering
Steady Rest

152 P

STA Self-Centering Steady Rest



Application / Benefits

Enhances the accuracy when machining unstable, heavy or long work piece

Technical features

The arms and center rollers are interconnected and designed to self-adjust to various size workpieces.

The mechanical design improves durability by eliminating the need for springs.

Fixed or Travelling Applications



Fixed Tandem Steady Rest

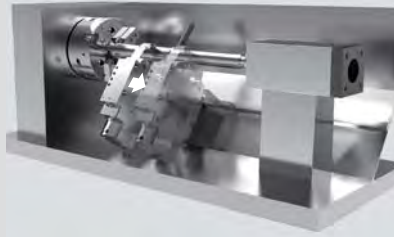

Travelling Steady Rest

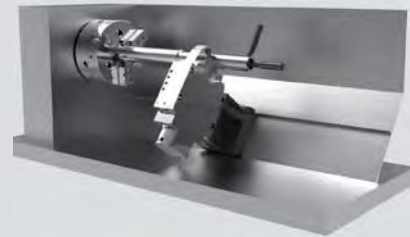

Fixed Steady Rest For End Machining

SPECIFICATIONS

	STA-1	STA-2	STA-3	STA-3.1	STA-3.2	STA-4	STA-5	STA-5.1	STA-6
Piston Area [cm ²]	7	19.6	50	50	50	78	78	78	132
Max. Clamping Force / Roller [kgf]	100	450	1000	1000	1000	1500	2000	2000	3000
Operation Pressure [bar]	Max.	50	70	60	60	60	80	80	70
	Min.	6	8	8	8	8	8	8	8
Centering Range [mm]	Max.	64	101	152	165	200	245	310	460
	Min.	4	8	12	20	50	30	45	125
Max. Roller Surface Speed [m/min]	800	800	725	725	725	715	700	700	700
Centering Accuracy [mm]	0.02	0.02	0.04	0.04	0.04	0.05	0.06	0.06	0.06
Repeatability Accuracy [mm]	0.005	0.005	0.007	0.007	0.007	0.007	0.01	0.01	0.01
Weight [kg]	6	14	39	40	43	92	152	155	420

STA

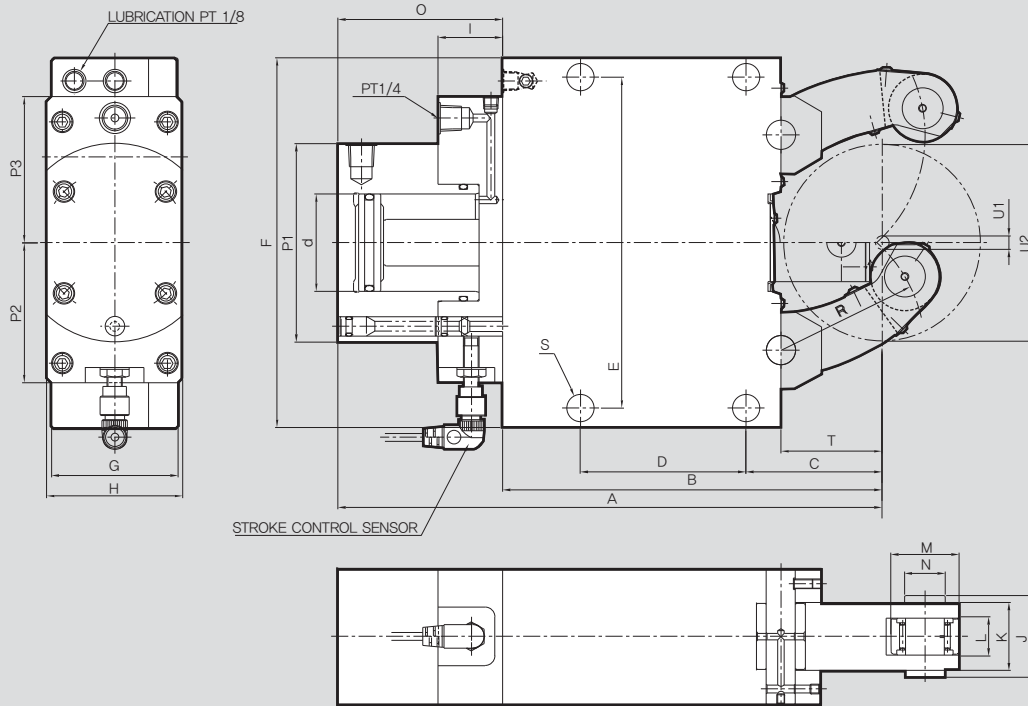

DIMENSIONS

	STA-1	STA-2	STA-3	STA-3.1	STA-3.2	STA-4	STA-5	STA-5.1	STA-6
A	207	279.5	431	440	455	608	697.5	717.5	944.5
B	137	195	312	320	335	448	510	530	709
C	51	70	115	123	138	146	178	198	215
D	64	85	135	135	135	240	270	270	330
E	118	170	262	262	262	365	400	400	640
F	132	190	290	290	290	400	440	440	680
G	55	70	85	85	85	110	145	145	145
H	70	70	100	100	100	144	144	144	158
I	33	33	37	37	37	37	37	37	37
J	24	42	52	52	52	67	83	83	83
K	20	35	45	45	45	60	75	75	75
L	12	19	25	25	25	25	29	29	29
M	19	35	47	47	47	52	62	62	80
N	6	21	25	25	25	32	36	36	42
O	70	84.5	120	120	120	160	187.5	187.5	235.5
P1	84	102	137	137	137	165	165	165	190
P2	66	72	90	90	90	102	102	102	115
P3	66	75	100	100	100	110	110	110	130
R	50.5	74	119	124	139	172	209	229	290
S	11	14	18	18	18	23	23	23	27
T	37	52	85	93	103	128	160	180	175
U1	4	8	11	20	50	35	45	85	125
U2	64	101	152	165	220	245	310	350	460

STRA Wide-Opening Self-Centering Steady Rest



Application / Benefits

Enhances the accuracy when machining unstable, heavy or long work piece

Technical features

The arms and center rollers are interconnected and designed to self-adjust to various size workpieces

The mechanical design improves durability by eliminating the need for springs

The top arm pivots extra wide to allow for easier drop down loading when working on mills or flatbed lathes

Fixed or Travelling Applications

STA
Conventional model

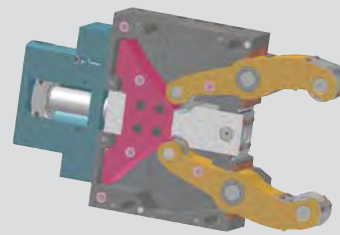
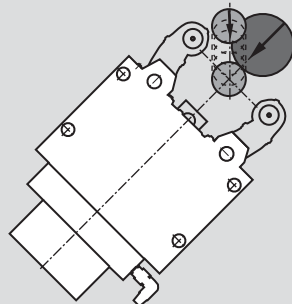

STRA
The wide opening arm of the STRA steady rest makes vertical loading and automation convenient

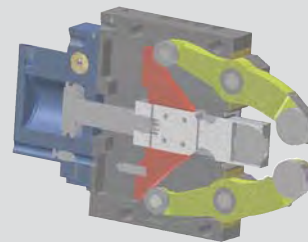
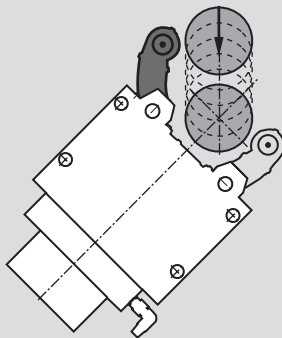

SPECIFICATIONS

	STRA-1	STRA-2	STRA-3	STRA-3.1	STRA-4	STRA-5	STRA-6
Piston Area [cm ²]	7	19.6	50	50	78	78	132
Max. Clamping Force / Roller [kgf]	100	450	1000	1000	1500	2000	3000
Operation Pressure [bar]	Max.	50	70	60	60	60	80
	Min.	6	8	8	8	8	8
Centering Range [mm]	Max.	52	80	130	150	220	268
	Min.	4	8	12	22	30	50
Max. Roller Surface Speed [m/min]	800	800	725	725	715	700	700
Centering Accuracy [mm]	0.02	0.02	0.04	0.04	0.05	0.06	0.06
Repeatability Accuracy [mm]	0.005	0.005	0.007	0.007	0.007	0.01	0.01
Weight [kg]	6	14	39	40	92	152	420

STRA

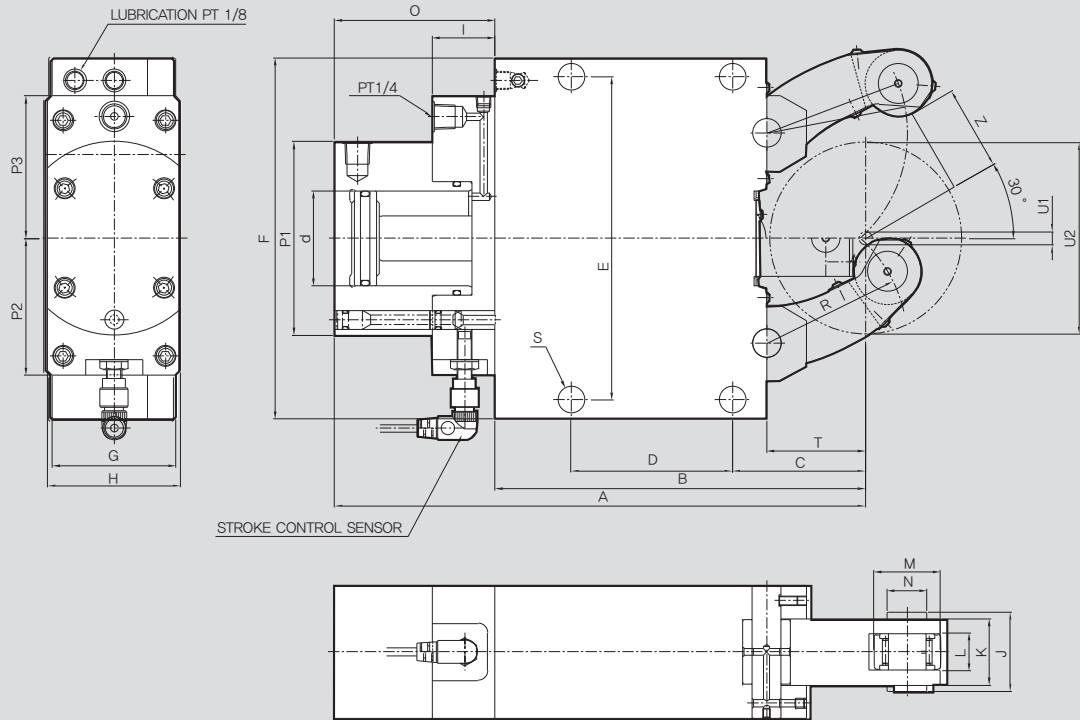

DIMENSIONS

	STRA-1	STRA-2	STRA-3	STRA-3.1	STRA-4	STRA-5	STRA-6
A	207	279.5	431	440	608	688.5	944.5
B	137	195	312	320	448	510	709
C	51	70	115	123	146	178	215
D	64	85	135	135	240	270	330
E	118	170	262	262	365	400	640
F	132	190	290	290	400	440	680
G	55	70	85	85	110	145	145
H	70	70	100	100	144	144	158
I	33	33	37	37	37	37	37
J	24	42	52	52	67	83	83
K	20	35	45	45	60	75	75
L	12	19	25	25	25	29	29
M	19	35	47	47	52	62	80
N	6	21	25	25	32	36	42
O	70	84.5	120	120	160	187.5	235.5
P1	84	102	137	137	165	165	190
P2	66	72	90	90	102	102	115
P3	66	75	100	100	110	110	130
R	50.5	74	119	124	172	209	290
S	11	14	18	18	23	23	27
T	37	52	85	93	128	160	175
Z	26.5	41	66	76	111	135	230
U1	4	8	12	22	30	50	160
U2	52	80	130	150	220	268	460



NC ROTARY TABLE

Samchully 4th and 5th axis rotary tables expand machine capacity in a cost-effective manner, comprehensive manner.

High quality coupled with full integration support have found Samchully success in the market as a leading supplier of rotary tables.



RDN-250i

Zero Backlash NC Rotary Table

159 P



S-170F2

4th axis NC Rotary Table

167 P



S-120/L

Controller type for NC Rotary Table

175 P



RED-100

Electric Discharge NC Rotary Table

160 P



S-200F4

4th axis NC Rotary Table

168 P



S-170/L

Controller type for NC Rotary Table

176 P



RHB-400F22

Horizontal Built-in NC Rotary Table

161 P



S-250F4

4th axis NC Rotary Table

169 P



S-200/L

Controller type for NC Rotary Table

177 P



RTM-250i

Manual Tilting NC Rotary Table

162 P

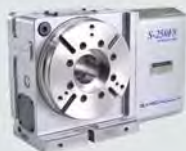

S-250F8

4th axis NC Rotary Table

170 P



S-250i/iL

Controller type for NC Rotary Table

178 P



MTR1-324FF

4th axis Trunnion Tilting NC Rotary Table

163 P



S-320F8

4th axis NC Rotary Table

171 P



S-320i/Li

Controller type for NC Rotary Table

179 P



DiM-260F

Direct Drive Motor NC Rotary Table

164 P



S-430F22

4th axis NC Rotary Table (Big Bore Type)

172 P



HRS-174F2

4th axis Hydraulic NC Rotary Table

180 P



200AH-C

Air Booster

165 P



S-515F22

4th axis NC Rotary Table (Big Bore Type)

173 P



HRS-204F4

4th axis Hydraulic NC Rotary Table

181 P



S-120F2

4th axis NC Rotary Table

166 P



S-650F22

4th axis NC Rotary Table (Big Bore Type)

174 P



HRS-254F4

4th axis Hydraulic NC Rotary Table

182 P



HRS-254F8

4th axis Hydraulic NC Rotary Table

183 P



TR-120,200i

Controller type for Tilting NC Rotary Table

191 P



DM-170

Direct Drive Motor NC Rotary Table

199 P



HRS-324F8

4th axis Hydraulic NC Rotary Table

184 P



TR-250i

Controller type for Tilting NC Rotary Table

192 P

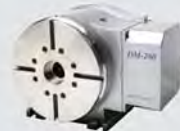

DM-260

Direct Drive Motor NC Rotary Table

200 P



HRS-204,254i

Controller type Hydraulic NC Rotary Table

185 P



MTR2-17432ii

Controller type for Multi Spindle Tilting NC Rotary Table

193 P



SR-200F4

Rear Mounted Motor 4th axis NC Rotary Table

201 P



HRS-324i

Controller type Hydraulic NC Rotary Table

186 P



MTR2-20435ii, 20435FF

5th axis for Multi Spindle Tilting NC Rotary Table

194 P

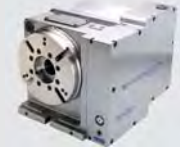

SR-200i

Rear Mounted Motor Controller type NC Rotary Table

202 P



TR-120FF

4th, 5th axis for Tilting NC Rotary Table

187 P



MTR2-25440ii, 25440FF

5th axis for Multi Spindle Tilting NC Rotary Table

195 P



MUT-600

Manual Turn Table

203 P



TR-200FF

4th, 5th axis for Tilting NC Rotary Table

188 P



MS2-170F4

4th axis type for Multi Spindle NC Rotary Table

196 P



TS (12-32)

Tail Stock (Manual Type)

204 P



TR-250FF

4th, 5th axis for Tilting NC Rotary Table

189 P



MS2-170LF4

4th axis type for Multi Spindle NC Rotary Table

197 P



TS (43-65)

Tail Stock (Manual Type)

205 P



TR-320FF

4th, 5th axis for Tilting NC Rotary Table

190 P



MS2-170i/Li

Controller type for Multi Spindle NC Rotary Table

198 P



TS-AH

Tail Stock (Air / Hydraulic Type)

206 P



SP-A

Tail Spindle
(Air Clamp Type)

207 P

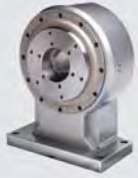

SP-H

Tail Spindle
(Hydraulic Clamp Type)

208 P



50AH-C

Air Booster (Single)

209 P



50AH-T

Air Booster (Twin)

210 P



NeoCon

Samchully Own
Controller

212 P

Application

217 P



RDN-250i Zero Backlash NC Rotary Table



Application / Benefits

High-Definition Split System with ROLLER CAM DRIVE
Zero Backlash with ROLLER CAM DRIVE

Model No.

RDN-250 i

Motor Spec
Table Diameter
TYPE : Roller Cam Drive NC Rotary Table

Servo Motor Maker

F : FANUC H : HEIDENHAIN
S : SIEMENS L : LS MECAPION
M : MITSUBISHI SY : SANYO
P : PANASONIC FA : FAGOR
Y : YASKAWA O : OKUMA

RDN-250i

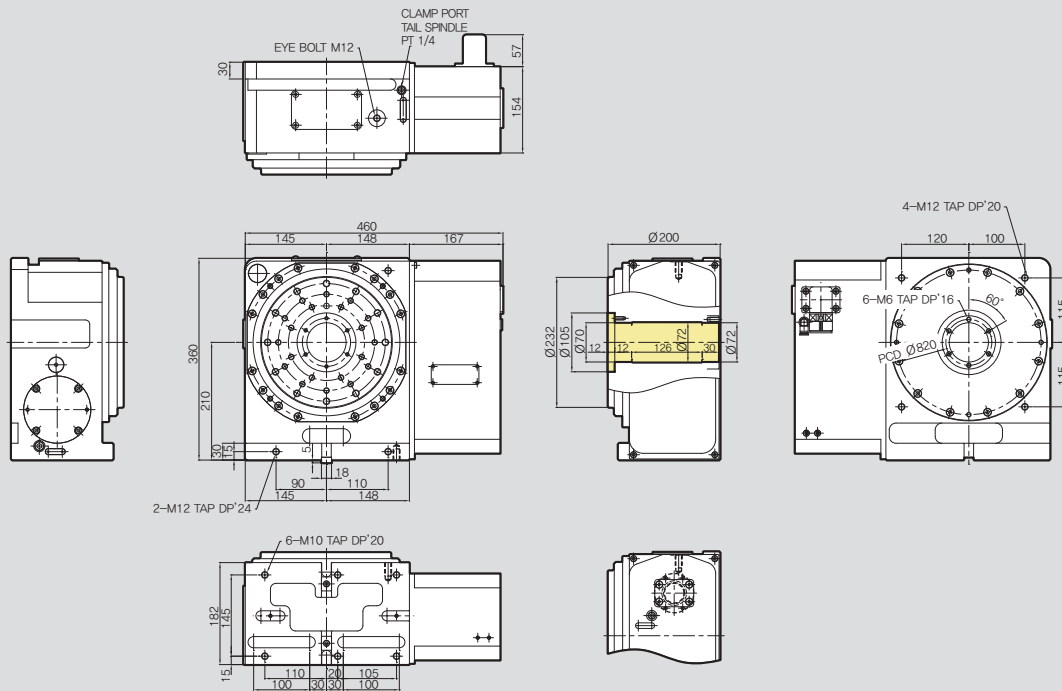

SPECIFICATIONS

Table Dia. [mm]	232
Center Height [mm]	210
Resister Dia. On Face Plate	105
Spindle Through Hole Dia. [mm]	70
Clamp Method	Pneumatic
Allowable Work Inertia [kgm ²]	-
Clamp Torque [N · m]	-
Max. Spindle Speed [mm ⁻¹]	30
Gear Ratio [mm]	1/60
Repeatability Accuracy [sec]	-
Indexing Accuracy [sec]	-
Weight [kg]	115

Allowable load	Horizontal [kg]		250
	Vertical [kg]		125
Allowable cutting load	F [kN]		20
	F x L [N-m]		-
Allowable Cutting Torque	F x L [N-m]		-
	[N-m]		-

RED-100 Electric Discharge NC Rotary Table



Application / Benefits

Special Alloy With Lightweight Design
 Long Workpieces(Ø40mm)
 Dampproof, Dustproof Design(Ip 68)

Model No.

RED-100

Table Diameter
 TYPE : Electric Discharge NC Rotary Table

RED-100

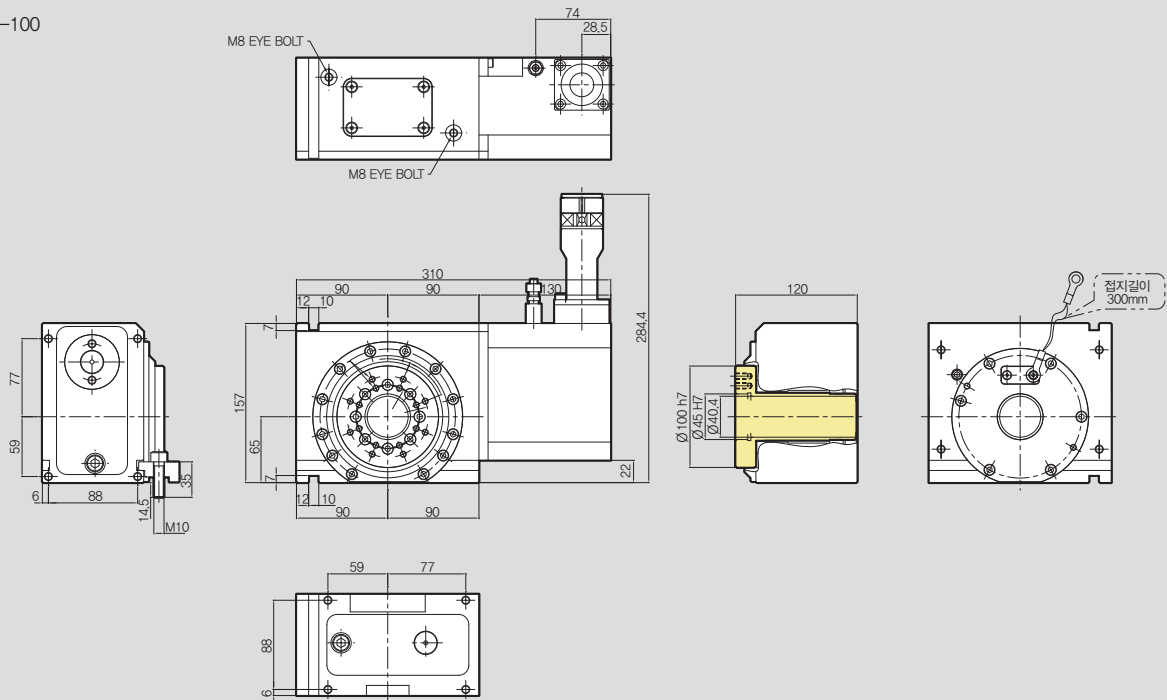

SPECIFICATIONS

Table Dia. [mm]	Ø100
Center Height [mm]	65
Resister Dia. On Face Plate	Ø45
Spindle Through Hole Dia. [mm]	Ø40.4
Clamp Method	Pneumatic
Allowable Work Inertia [kgm ²]	-
Clamp Torque [N · m]	-
Max. Spindle Speed [mm ⁻¹]	-
Min. Spindle Speed [mm ⁻¹]	-
Gear Ratio [mm]	1/45
Repeatability Accuracy [sec]	30
Indexing Accuracy [sec]	5
Weight [kg]	25
Max. Machine Current [A]	Less than 20A

Allowable load	Horizontal [kg]		-
	Vertical [kg]		20
	F [kN]		-

RHB-400F22 Horizontal Built-in NC Rotary Table



Application / Benefits

Parallel Rotary Table, Internal Rotary Joint (10+1 Port.)

Model No.

RHB-400F22

— Servo Motor Maker
 — Table Diameter
 — TYPE : Single Spindle NC Rotary Table(Standard)



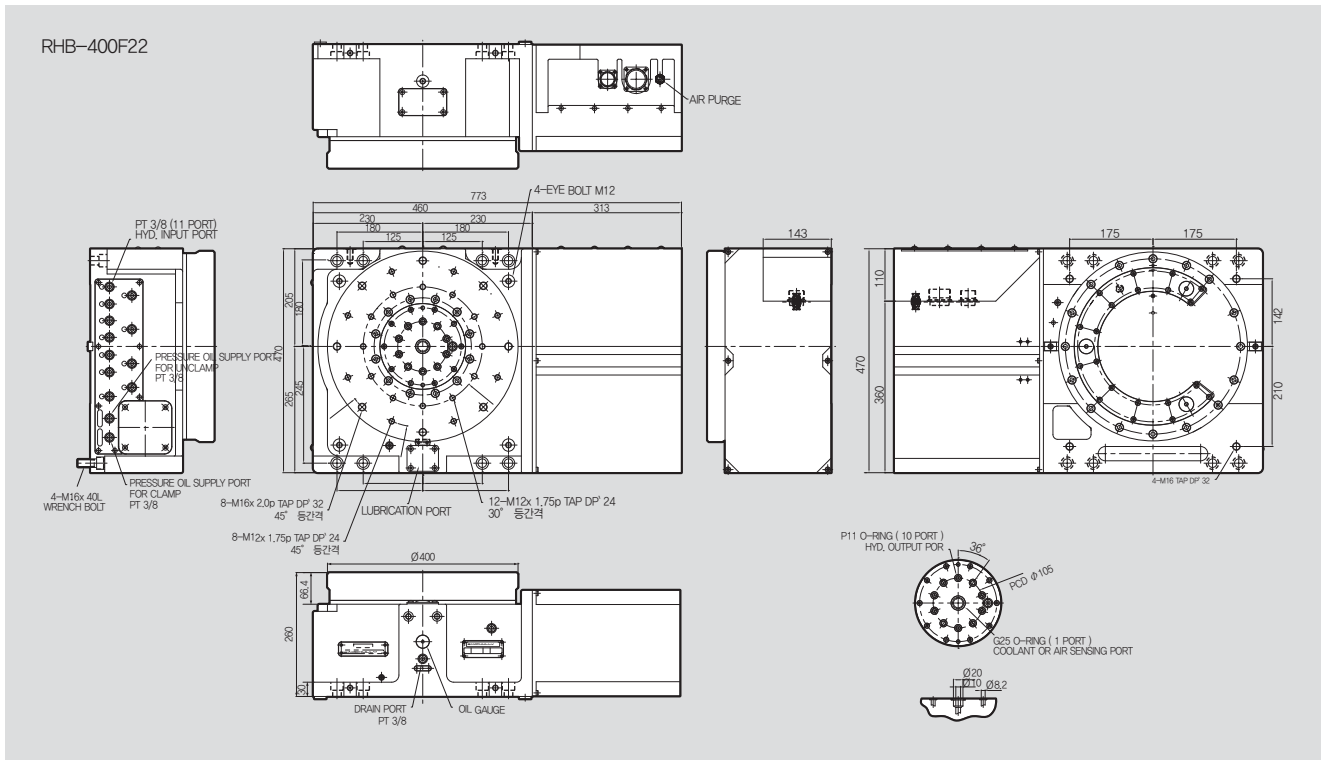

Servo Motor Maker

F : FANUC H : HEIDENHAIN
 S : SIEMENS L : LS MECAPION
 M : MITSUBISHI SY : SANYO
 P : PANASONIC FA : FAGOR
 Y : YASKAWA O : OKUMA



SPECIFICATIONS

Table Dia. [mm]	Ø400
Table Height [mm]	235
Resister Dia. On Face Plate	-
Spindle Through Hole Dia. [mm] ±	-
Clamp Method	Hydraulic Max. 35 bar
Allowable Work Inertia [kgm ²]	-
Clamp Torque [N · m]	3000
Max. Spindle Speed [mm ⁻¹]	44.4
Gear Ratio [mm]	1/45
Repeatability Accuracy [sec]	±10
Indexing Accuracy [sec]	5
Weight [kg]	650
Servo Motor [FANUC]	aiF22 / 3000
Rotary Joint Port	10 + 1 Port. (10 Port Hydraulic Max. 300bar)

Allowable load	Horizontal [kg]		600
	F [kN]		-
Allowable cutting load	F x L [N·m]		3000
	Allowable Cutting Torque [N·m]		1700

RTM-250i Manual Tilting NC Rotary Table

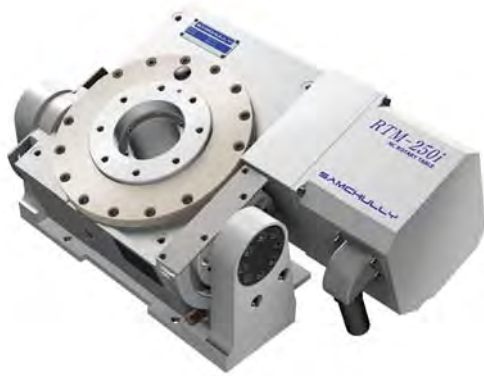

Application / Benefits

Easy Manual Adjustment for Inclination
Inclination Adjustable with a Wrench without any other controller

Model No.

RTM-250 i

Motor Spec
Table Diameter
TYPE : Manual Tilting Rotary Table

RTM-250i

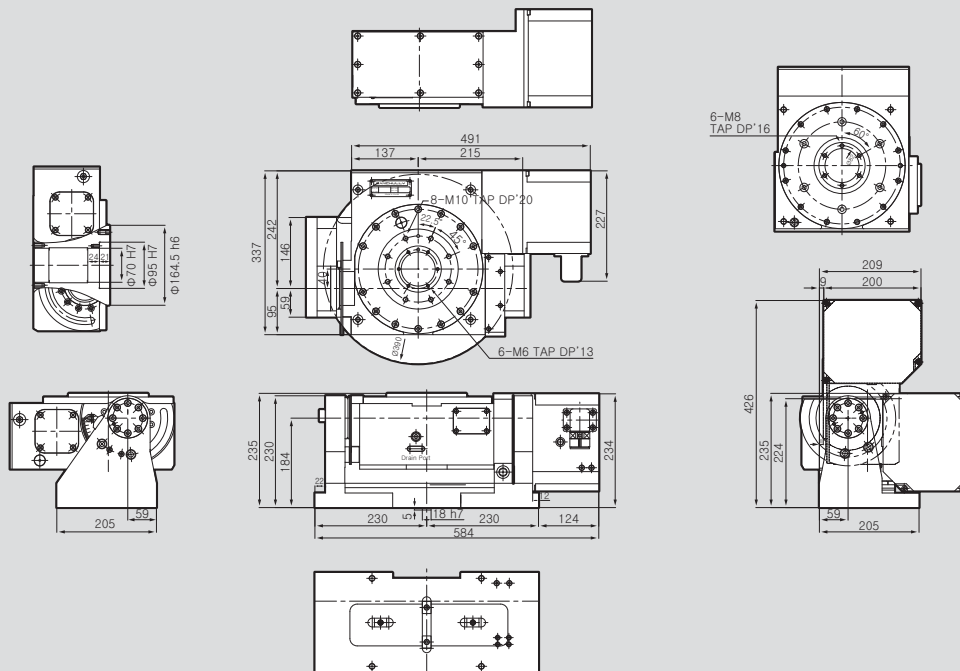

SPECIFICATIONS

Tilting Range: 0° ~90°

Spindle Dia. [mm]	Ø164.5
Center Height [mm]	235
Resister Dia. On Face Plate	Ø95
Spindle Through Hole Dia. [mm]	Ø70
Clamp Method	Pneumatic
Allowable Work Inertia [kgm ²]	1.95
Clamp Torque [N · m]	750
Max. Spindle Speed [mm ⁻¹]	33.3
Gear Ratio Tilt Axis [mm]	1/90
Gear Ratio Rotate Axis [mm]	1/72
Repeatability Accuracy [sec]	20
Indexing Accuracy [sec]	4
Weight [kg]	125
Servo Motor	SGMP5-15A2A6S

허용하중 Allowable load	Horizontal [kg]		200
	Vertical [kg]		125
	F [kN]		21
절삭 허용하중 Allowable cutting load	F x L [N·m]		1600
	F x L [N·m]		750
허용 절삭 토크 Allowable Cutting Torque	[N·m]		480

MTR1-324FF 4th axis Trunnion Tilting NC Rotary Table



Application / Benefits

Work Piece handling up to Ø800, Single Spindle Tilting Series
Easy Jig Design with Strong Clamp Power

Model No.

MTR1-324FF

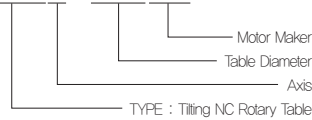

Servo Motor Maker

- F : FANUC H : HEIDENHAIN
- S : SIEMENS L : LS MECAPION
- M : MITSUBISHI SY : SANYO
- P : PANASONIC FA : FAGOR
- Y : YASKAWA O : OKUMA

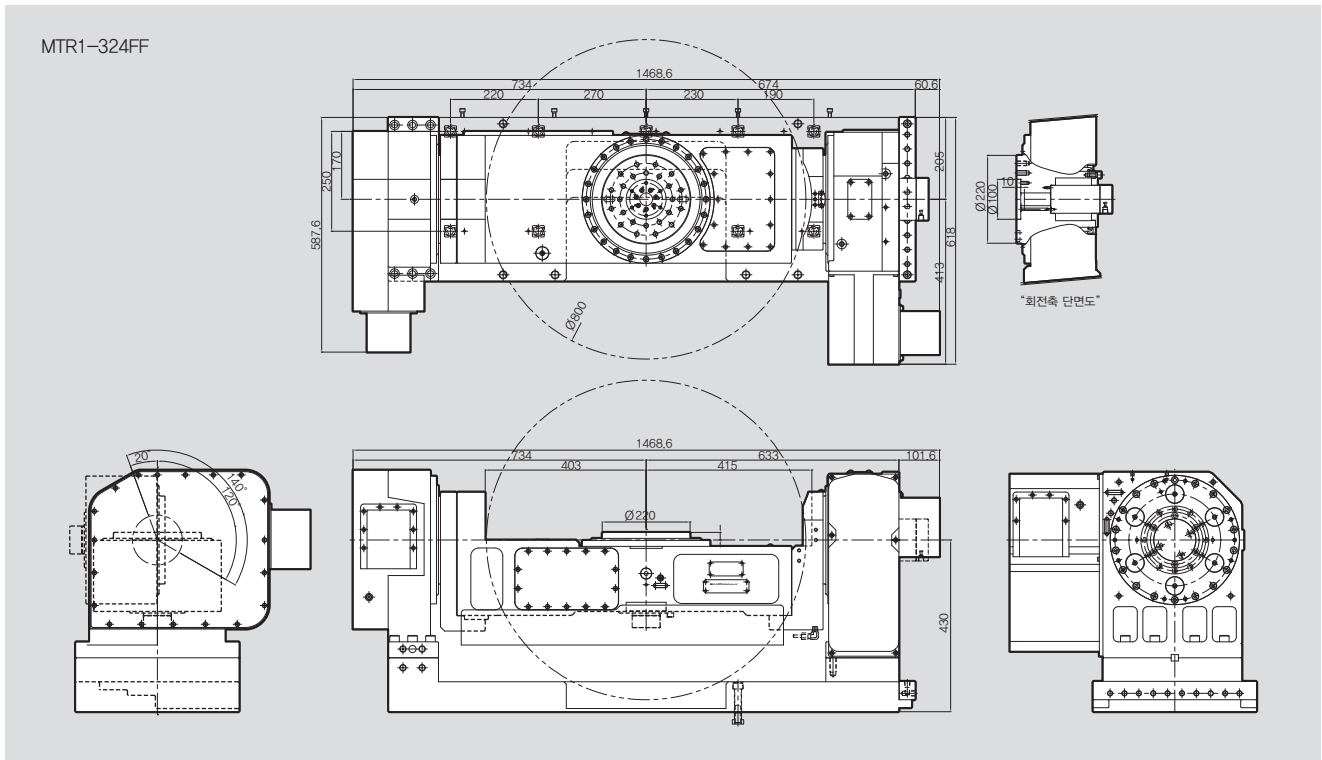

NC Rotary Table

SPECIFICATIONS

Tilting Range: -20° ~120°

Spindle Dia. [mm]	Ø220	
Table Height [mm]	449	
Resister Dia. On Face Plate	Ø100	
Spindle Through Hole Dia. [mm] ±	Ø35	
Clamp Method	Hydraulic Max. 35 bar	
Allowable Work Inertia [kgm ²]	-	
Weight [kg]	900	
	Rotating Axis	Tilting Axis
Clamp Torque [N · m]	1500	2600
Max. Spindle Speed [mm ⁻¹]	25	25
Gear Ratio [mm]	1/120	1/120
Repeatability Accuracy [sec]	±10	±10
Indexing Accuracy [sec]	5	5
Servo Motor [FANUC]	aiF4 / 4000	aiF8 / 3000

Allowable load	Horizontal [kg]		100
	Vertical [kg]		-
Allowable cutting load	F [kN]		-
	F x L [N·m]		-
	F x L [N·m]		-
Allowable Cutting Torque	[N·m]		-

DiM-260F Direct Drive Motor NC Rotary Table



Application / Benefits

High-Definition Split System with DD Motor
Zero Backlash

Model No.

DiM-260F



Servo Motor Maker

- | | |
|----------------|-----------------|
| F : FANUC | H : HEIDENHAIN |
| S : SIEMENS | L : LS MECAPION |
| M : MITSUBISHI | SY : SANYO |
| P : PANASONIC | FA : FAGOR |
| Y : YASKAWA | O : OKUMA |

DiM-260F

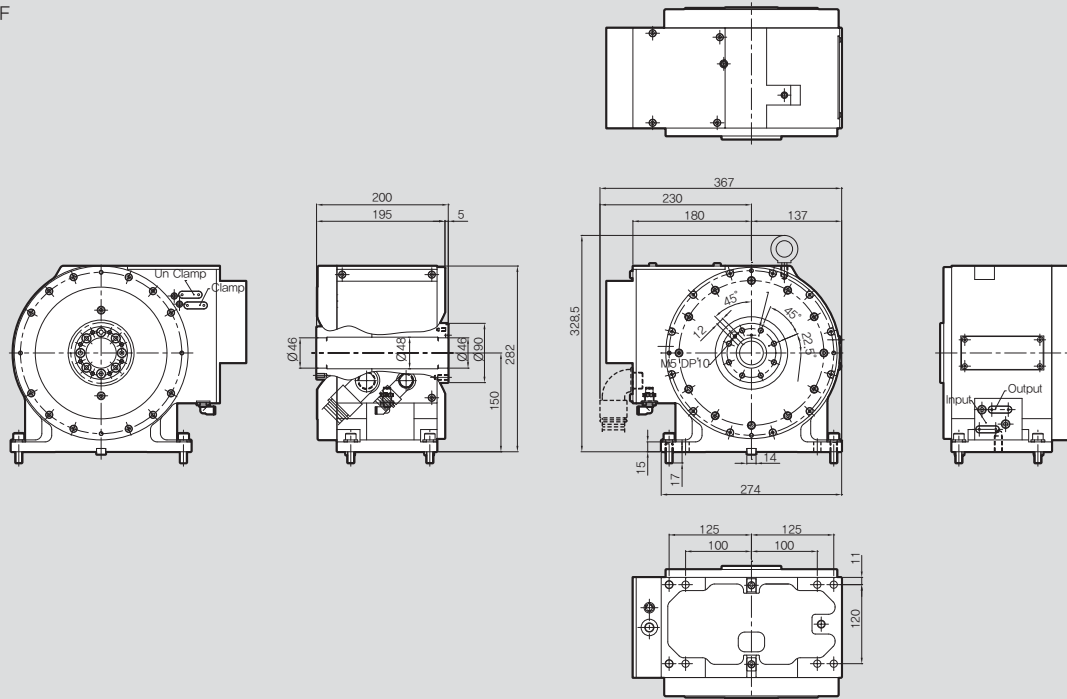

SPECIFICATIONS

Table Dia. [mm]	Ø90
Center Height [mm]	150
Resister Dia. On Face Plate	Ø46
Spindle Through Hole Dia. [mm]	Ø46
Clamp Method	Pneumatic
Allowable Work Inertia [kgm ²]	0.033
Clamp Torque [N · m]	500
Max. Spindle Speed [mm ⁻¹]	150
Gear Ratio [mm]	-
Repeatability Accuracy [sec]	-
Indexing Accuracy [sec]	±10
Weight [kg]	75

Allowable load	Horizontal [kg]		-
	Vertical [kg]		100
Allowable cutting load	F [kN]		-
	F x L [N·m]		600
	F x L [N·m]		500
	Allowable Cutting Torque [N·m]		-

200AH-C Air Booster



Application / Benefits

High-Volume Air Buster (200cc), Oil Pressured Pneumatic Clamp.
Exclusively for S-430, S-515, S-650 Open Center Chuck and TR-320.

Model No.

200 AH-C

Operation Type : Single
TYPE : AH -C series / Air Booster
Pressure

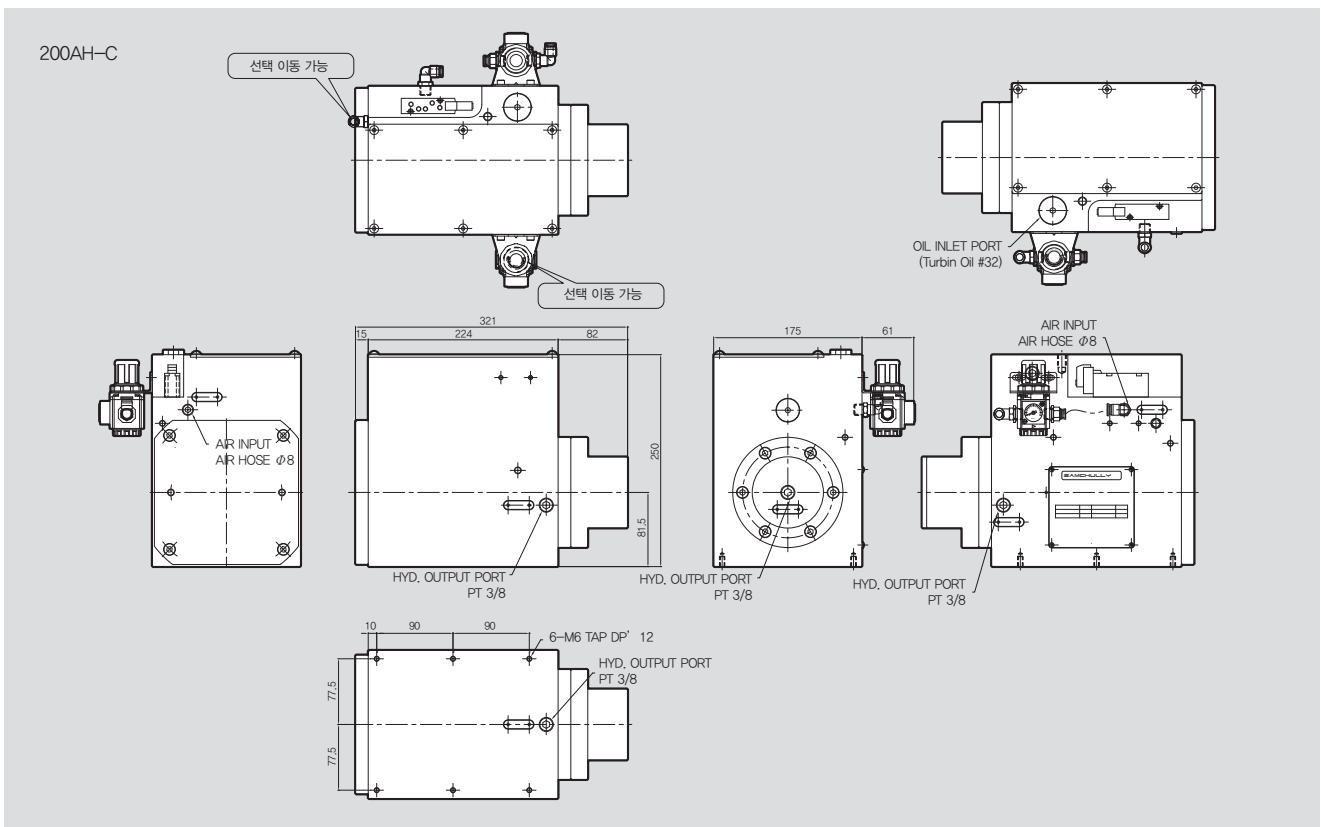

SPECIFICATIONS

Input Air Pressure	0.4 ~ 0.45
Output Hydraulic Pressure	3.2 ~ 3.6
Solenoid Voltage	DC 24 V
Multiplication Ratio	1 : 8

Recommended Oil	Turbine Oil #32
Discharge Rate	200cc
Weight [kg]	23

S-120F2 4th axis NC Rotary Table



Application / Benefits

High Precision&High Speed Systems, Vertical & Horizontal available
Compact Design, Extremely Rigid Body, High Clamping power

Model No.

S-120 F2



Servo Motor Maker

- | | |
|----------------|-----------------|
| F : FANUC | H : HEIDENHAIN |
| S : SIEMENS | L : LS MECAPION |
| M : MITSUBISHI | SY : SANYO |
| P : PANASONIC | FA : FAGOR |
| Y : YASKAWA | O : OKUMA |

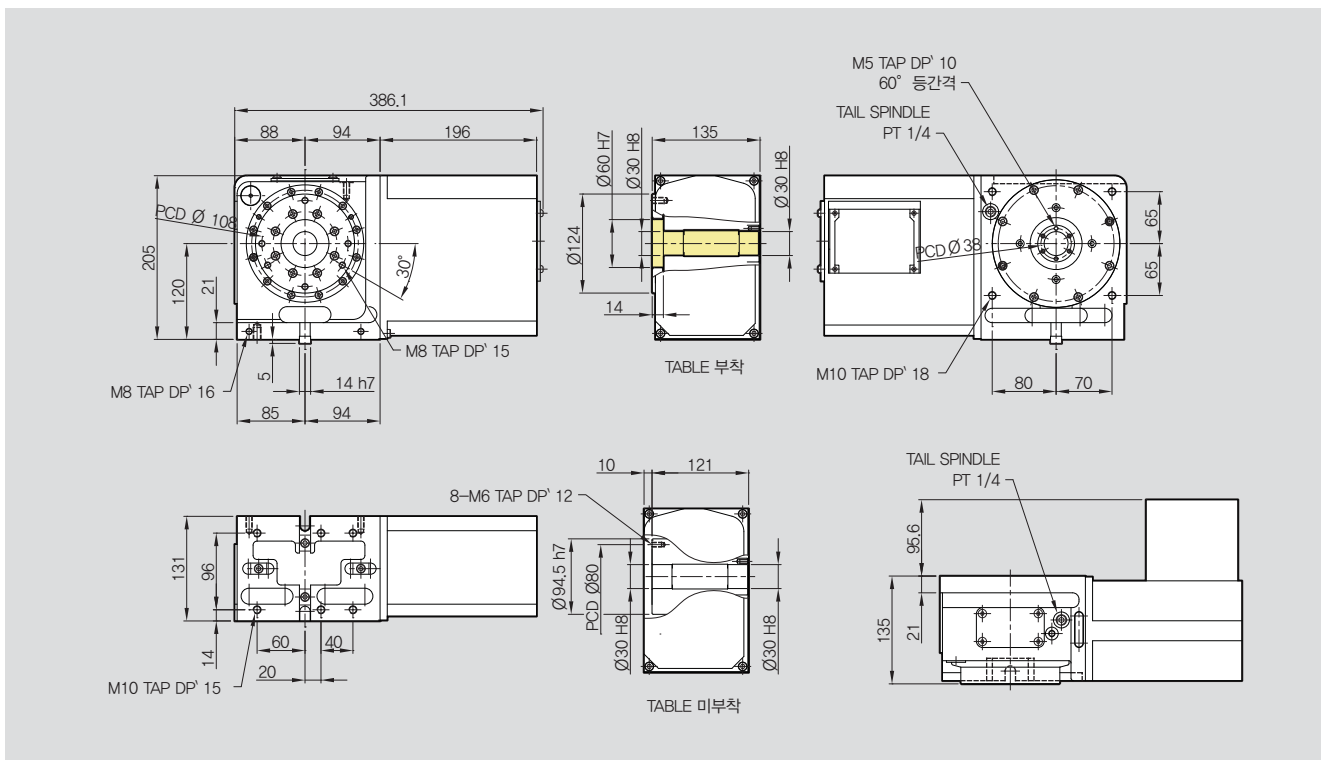

SPECIFICATIONS

Table Dia. [mm]	Ø124
Center Height [mm]	120
Resister Dia. On Face Plate	Ø60H7
Spindle Through Hole Dia. [mm]	Ø30H8
Clamp Method	Pneumatic
Allowable Work Inertia [kgm ²]	0.22
Clamp Torque [N · m]	150
Max. Spindle Speed [mm ⁻¹]	50
Gear Ratio [mm]	1/60
Repeatability Accuracy [sec]	4
Indexing Accuracy [sec]	30
Weight [kg]	35
Servo Motor [FANUC]	aiF2 / 5000

Allowable load	Horizontal [kg]		120
	Vertical [kg]		60
Allowable cutting load	F [kN]		8
	F x L [N·m]		350
Allowable Cutting Torque	F x L [N·m]		150
	[N·m]		180

S-170F2 4th axis NC Rotary Table



Application / Benefits

High Precision & High Speed Systems, Vertical & Horizontal available
 Compact Design, Extremely Rigid Body
 Realize High Clamping Force by applying Double Piston

Model No.

S-170 F2



Servo Motor Maker

- | | |
|----------------|-----------------|
| F : FANUC | H : HEIDENHAIN |
| S : SIEMENS | L : LS MECAPION |
| M : MITSUBISHI | SY : SANYO |
| P : PANASONIC | FA : FAGOR |
| Y : YASKAWA | O : OKUMA |

S-170F2

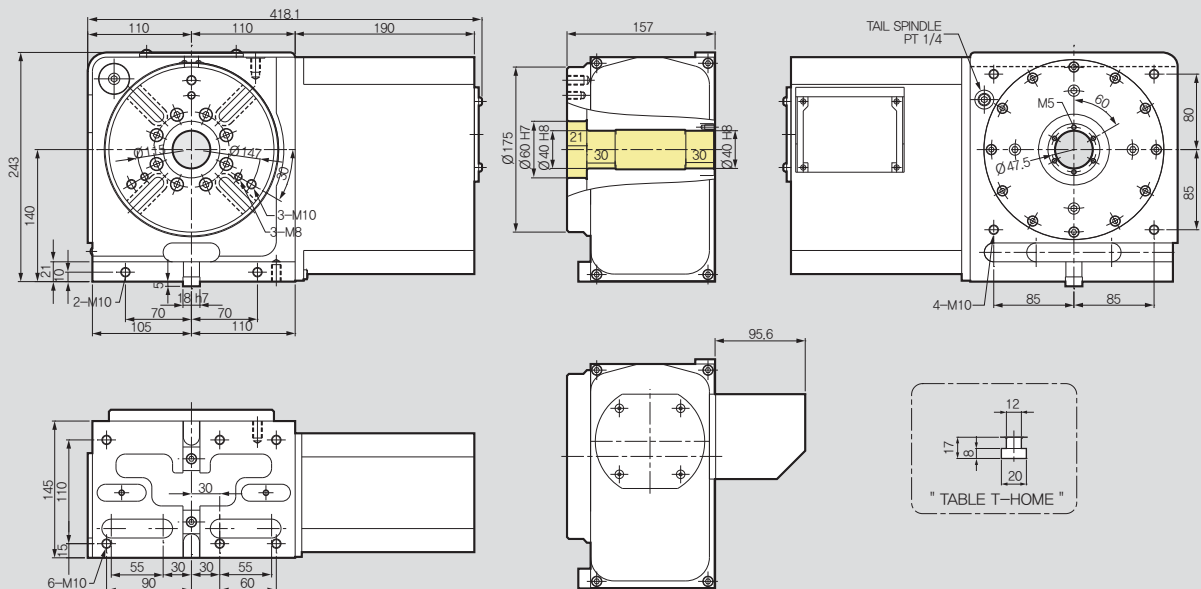

SPECIFICATIONS

Table Dia. [mm]	Ø175
Center Height [mm]	140
Resister Dia. On Face Plate	Ø60H7
Spindle Through Hole Dia. [mm]	Ø40H8
Clamp Method	Pneumatic
Allowable Work Inertia [kgm ²]	0.51
Clamp Torque [N · m]	380
Max. Spindle Speed [mm ⁻¹]	41.6
Gear Ratio [mm]	1/72
Repeatability Accuracy [sec]	4
Indexing Accuracy [sec]	20
Weight [kg]	52
Servo Motor [FANUC]	aiF2 / 5000

Allowable load	Horizontal [kg]		160
	Vertical [kg]		80
Allowable cutting load	F [kN]		10
	F x L [N·m]		600
Allowable Cutting Torque [N·m]	F x L [N·m]		380
			220

S-200F4 4th axis NC Rotary Table



Application / Benefits

High Precision & High Speed Systems, Vertical & Horizontal available
Compact Design, Extremely Rigid Body
Realize High Clamping Force by applying Double Piston

Model No.

S-200 F4

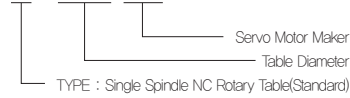

Servo Motor Maker

F : FANUC H : HEIDENHAIN
S : SIEMENS L : LS MECAPION
M : MITSUBISHI SY : SANYO
P : PANASONIC FA : FAGOR
Y : YASKAWA O : OKUMA

S-200F4

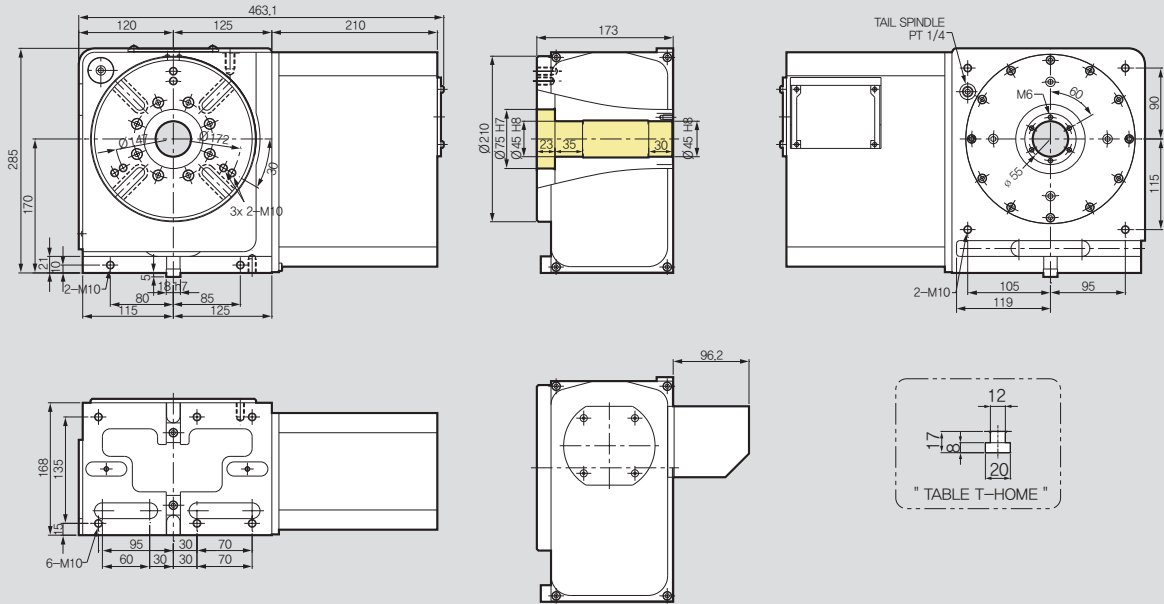

NC Rotary Table

SPECIFICATIONS

Table Dia. [mm]	Ø210
Center Height [mm]	170
Resister Dia. On Face Plate	Ø75H7
Spindle Through Hole Dia. [mm]	Ø45H8
Clamp Method	Pneumatic
Allowable Work Inertia [kgm ²]	0.8
Clamp Torque [N · m]	480
Max. Spindle Speed [mm ⁻¹]	33.3
Gear Ratio [mm]	1/90
Repeatability Accuracy [sec]	4
Indexing Accuracy [sec]	20
Weight [kg]	79
Servo Motor [FANUC]	aiF4 / 4000

Allowable load	Horizontal [kg]		200
	Vertical [kg]		100
Allowable cutting load	F [kN]		17
	F x L [N-m]		1100
Allowable Cutting Torque [N-m]	F x L [N-m]		480
			270

S-250F4 4th axis NC Rotary Table

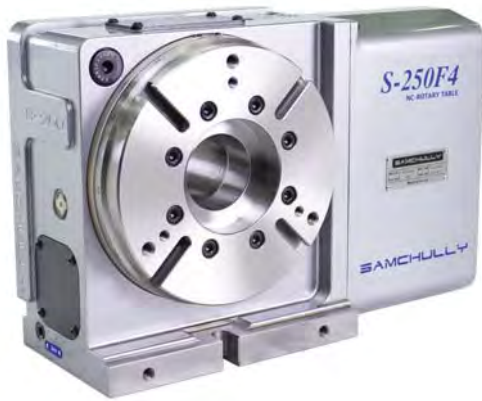

Application / Benefits

High Precision & High Speed Systems, Vertical & Horizontal available
 Compact Design, Extremely Rigid Body
 Realize High Clamping Force by applying Double Piston

Model No.

S-250 F4

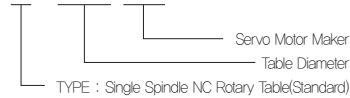

Servo Motor Maker

- | | |
|----------------|-----------------|
| F : FANUC | H : HEIDENHAIN |
| S : SIEMENS | L : LS MECAPION |
| M : MITSUBISHI | SY : SANYO |
| P : PANASONIC | FA : FAGOR |
| Y : YASKAWA | O : OKUMA |

S-250F4

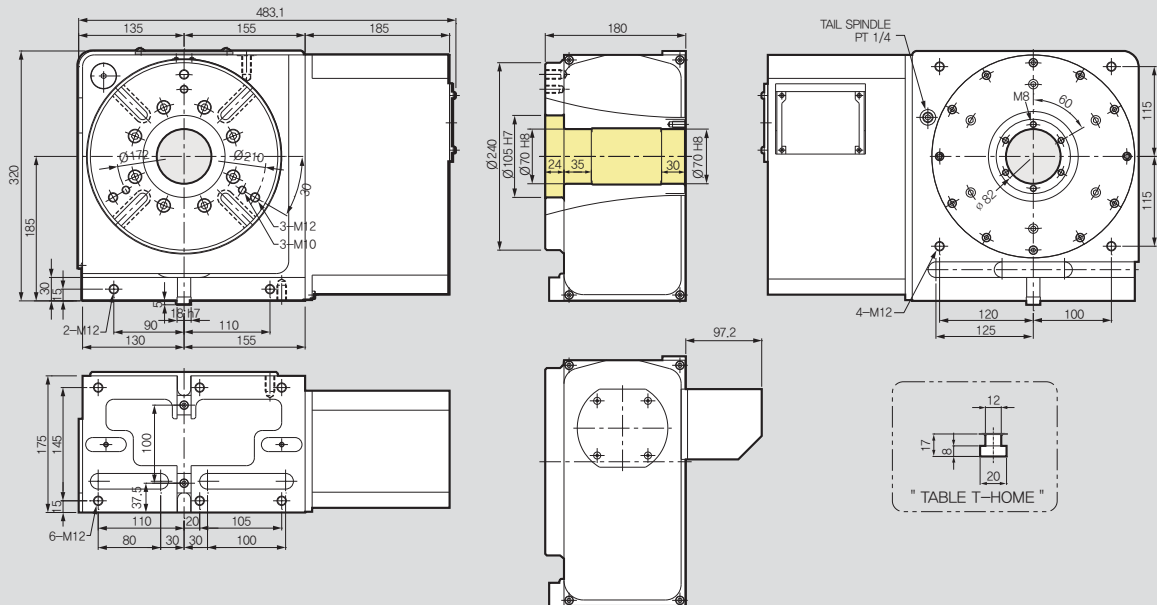

SPECIFICATIONS

Table Dia. [mm]	Ø240
Center Height [mm]	185
Resister Dia. On Face Plate	Ø105H7
Spindle Through Hole Dia. [mm]	Ø70H8
Clamp Method	Pneumatic
Allowable Work Inertia [kgm ²]	1.95
Clamp Torque [N · m]	750
Max. Spindle Speed [mm ⁻¹]	33.3
Gear Ratio [mm]	1/90
Repeatability Accuracy [sec]	4
Indexing Accuracy [sec]	20
Weight [kg]	100
Servo Motor [FANUC]	aiF4 / 4000

Allowable load	Horizontal [kg]		250
	Vertical [kg]		125
Allowable cutting load	F [kN]		21
	F x L [N-m]		1600
	F x L [N-m]		750
	Allowable Cutting Torque [N-m]		480

S-250F8 4th axis NC Rotary Table



Application / Benefits

High Precision & High Speed Systems, Vertical & Horizontal available
 Compact Design, Extremely Rigid Body
 Realize High Clamping Force by applying Double Piston

Model No.

S-250 F8



Servo Motor Maker

- | | |
|----------------|-----------------|
| F : FANUC | H : HEIDENHAIN |
| S : SIEMENS | L : LS MECAPION |
| M : MITSUBISHI | SY : SANYO |
| P : PANASONIC | FA : FAGOR |
| Y : YASKAWA | O : OKUMA |

S-250F8

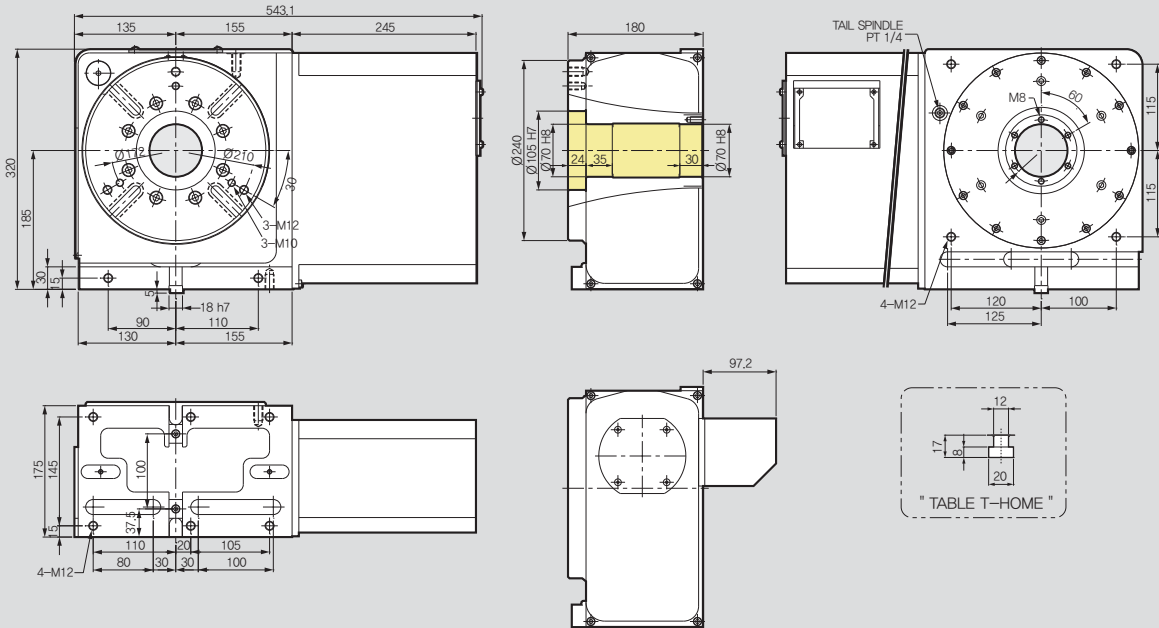

NC Rotary Table

SPECIFICATIONS

Table Dia. [mm]	Ø240
Center Height [mm]	185
Resister Dia. On Face Plate	Ø105H7
Spindle Through Hole Dia. [mm]	Ø70H8
Clamp Method	Pneumatic
Allowable Work Inertia [kgm ²]	3.12
Clamp Torque [N · m]	750
Max. Spindle Speed [mm ⁻¹]	33.3
Gear Ratio [mm]	1/90
Repeatability Accuracy [sec]	4
Indexing Accuracy [sec]	20
Weight [kg]	106
Servo Motor [FANUC]	aiF8 / 3000

Allowable load	Horizontal [kg]		250
	Vertical [kg]		125
Allowable cutting load	F [kN]		21
	F x L [N·m]		1600
	F x L [N·m]		750
	Allowable Cutting Torque [N·m]		600

S-320F8 4th axis NC Rotary Table



Application / Benefits

High Precision & High Speed Systems, Vertical & Horizontal available
 Compact Design, Extremely Rigid Body
 Realize High Clamping Force by applying Double Piston

Model No.

S-320 F8



Servo Motor Maker

- | | |
|----------------|-----------------|
| F : FANUC | H : HEIDENHAIN |
| S : SIEMENS | L : LS MECAPION |
| M : MITSUBISHI | SY : SANYO |
| P : PANASONIC | FA : FAGOR |
| Y : YASKAWA | O : OKUMA |

S-320F8

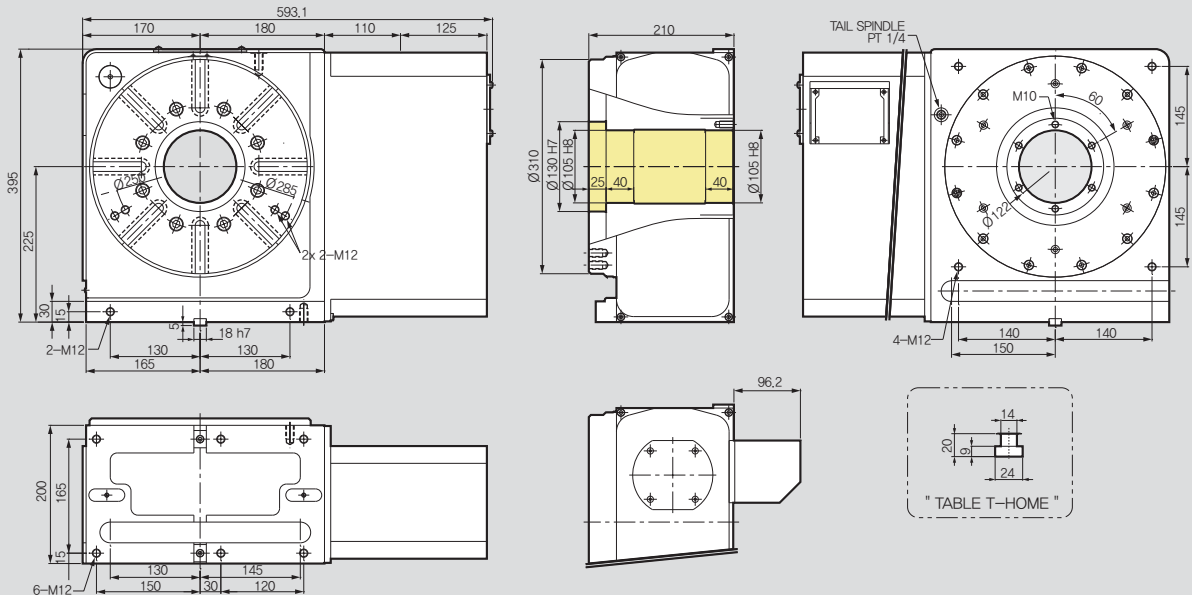

SPECIFICATIONS

Table Dia. [mm]	Ø310
Center Height [mm]	225
Resister Dia. On Face Plate	Ø130H7
Spindle Through Hole Dia. [mm]	Ø105H8
Clamp Method	Pneumatic
Allowable Work Inertia [kgm ²]	4.49
Clamp Torque [N · m]	1440
Max. Spindle Speed [mm ⁻¹]	25
Gear Ratio [mm]	1/120
Repeatability Accuracy [sec]	4
Indexing Accuracy [sec]	20
Weight [kg]	170
Servo Motor [FANUC]	aiF8 / 3000

Allowable load	Horizontal [kg]		350
	Vertical [kg]		180
Allowable cutting load	F [kN]		25
	F x L [N-m]		2400
Allowable Cutting Torque [N-m]	F x L [N-m]		1440
			800

S-430F22 4th axis NC Rotary Table (Big Bore Type)



Application / Benefits

High Precision & High Speed Systems, Vertical & Horizontal available
 Compact Design, Extremely Rigid Body, Large Through Hole
 High Clamping power (Hydraulic)

Model No.

S-430 F22

Servo Motor Maker
 Table Diameter
 TYPE : Single Spindle NC Rotary Table (Big Bore Type)

Servo Motor Maker

F : FANUC H : HEIDENHAIN
 S : SIEMENS L : LS MECAPION
 M : MITSUBISHI SY : SANYO
 P : PANASONIC FA : FAGOR
 Y : YASKAWA O : OKUMA

S-430F22

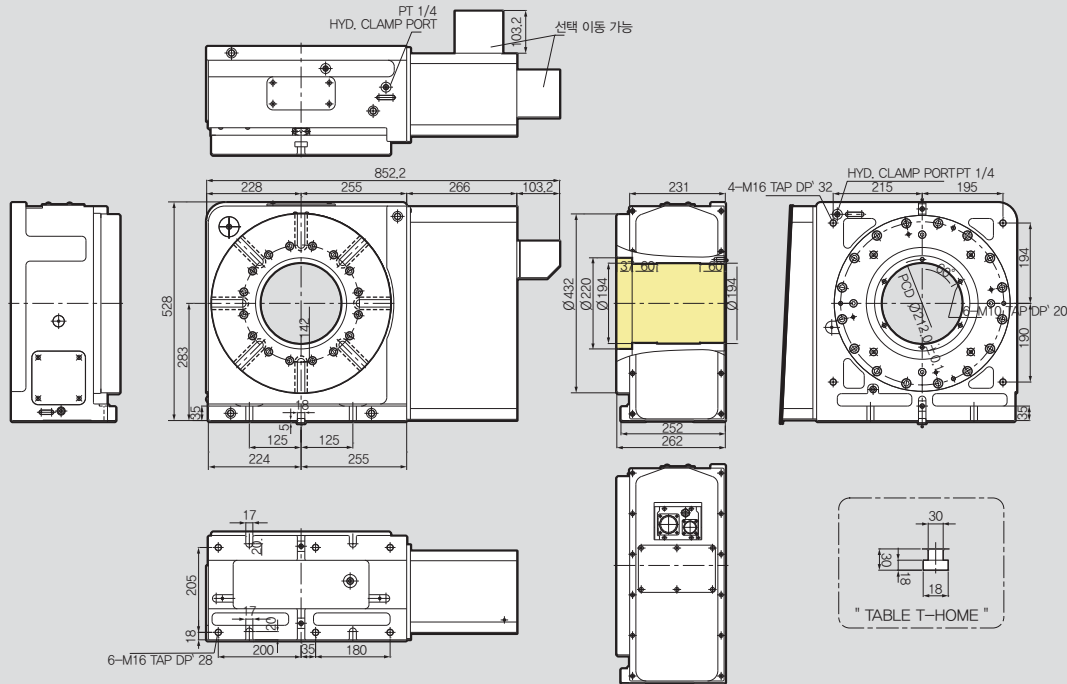

NC Rotary Table

SPECIFICATIONS

Table Dia. [mm]	Ø432
Center Height [mm]	283
Resister Dia. On Face Plate	Ø220H7
Spindle Through Hole Dia. [mm]	Ø194H8
Clamp Method	Hydraulic Max. 35bar
Allowable Work Inertia [kgm ²]	10.67
Clamp Torque [N · m]	2500
Max. Spindle Speed [mm ⁻¹]	25
Gear Ratio [mm]	1/120
Repeatability Accuracy [sec]	4
Indexing Accuracy [sec]	20
Weight [kg]	350
Servo Motor [FANUC]	aiF22 / 3000

Allowable load	Horizontal [kg]		500
	Vertical [kg]		250
Allowable cutting load	F [kN]		32
	F x L [N·m]		5000
Allowable Cutting Torque	F x L [N·m]		2500
	[N·m]		1700

S-515F22 4th axis NC Rotary Table (Big Bore Type)



Application / Benefits

High Precision & High Speed Systems, Vertical & Horizontal available
 Compact Design, Extremely Rigid Body, Large Through Hole
 High Clamping power (Hydraulic)

Model No.

S-515 F22

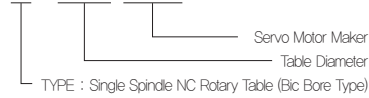

Servo Motor Maker

- | | |
|----------------|-----------------|
| F : FANUC | H : HEIDENHAIN |
| S : SIEMENS | L : LS MECAPION |
| M : MITSUBISHI | SY : SANYO |
| P : PANASONIC | FA : FAGOR |
| Y : YASKAWA | O : OKUMA |

S-515F22

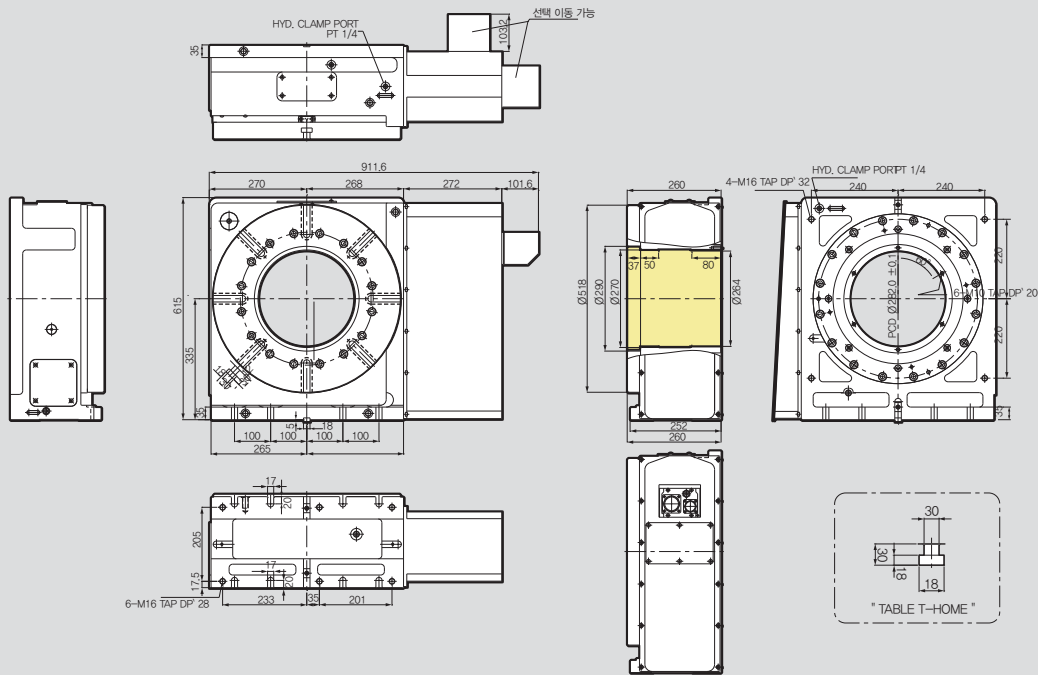

SPECIFICATIONS

Table Dia. [mm]	Ø518
Center Height [mm]	335
Resister Dia. On Face Plate	Ø290H7
Spindle Through Hole Dia. [mm]	Ø264H8
Clamp Method	Hydraulic Max. 35bar
Allowable Work Inertia [kgm ²]	19.97
Clamp Torque [N · m]	3200
Max. Spindle Speed [mm ⁻¹]	25
Gear Ratio [mm]	1/120
Repeatability Accuracy [sec]	4
Indexing Accuracy [sec]	20
Weight [kg]	430
Servo Motor [FANUC]	αiF22 / 3000

Allowable load	Horizontal [kg]		600
	Vertical [kg]		300
Allowable cutting load	F [kN]		50
	F x L [N-m]		8000
	F x L [N-m]		3200
Allowable Cutting Torque	[N-m]		2600

S-650F22 4th axis NC Rotary Table (Big Bore Type)



Application / Benefits

High Precision & High Speed Systems, Vertical & Horizontal available
 Compact Design, Extremely Rigid Body, Large Through Hole
 High Clamping power (Hydraulic)

Model No.

S-650 F22

— Servo Motor Maker
 — Table Diameter
 — TYPE : Single Spindle NC Rotary Table (Big Bore Type)

Servo Motor Maker

F : FANUC H : HEIDENHAIN
 S : SIEMENS L : LS MECAPION
 M : MITSUBISHI SY : SANYO
 P : PANASONIC FA : FAGOR
 Y : YASKAWA O : OKUMA

S-650F22

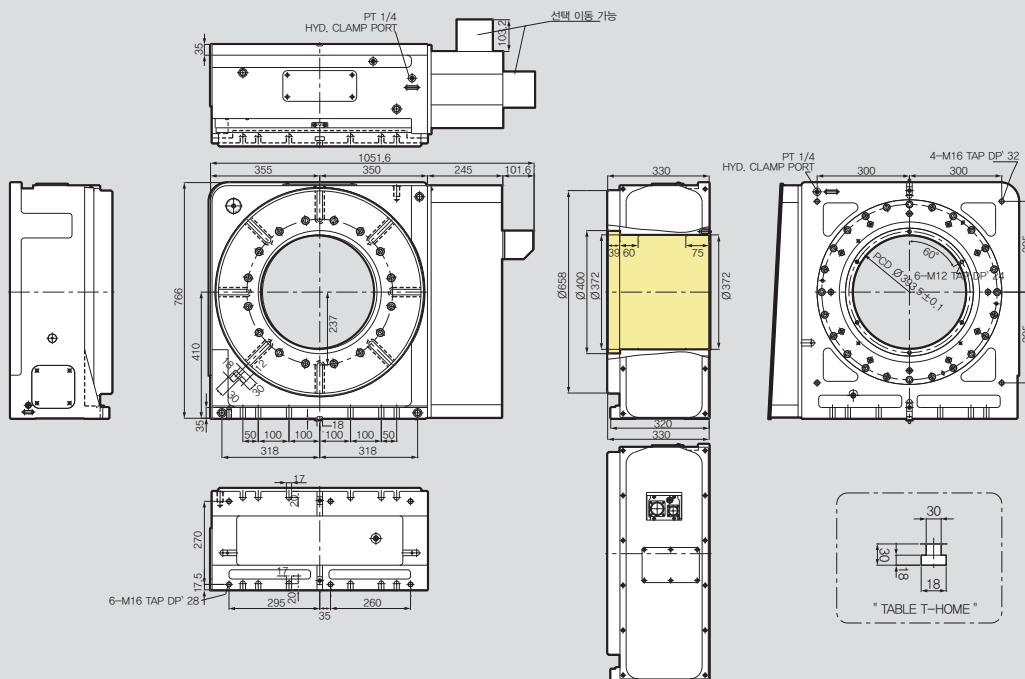

SPECIFICATIONS

Table Dia. [mm]	Ø656
Center Height [mm]	410
Resister Dia. On Face Plate	Ø400H7
Spindle Through Hole Dia. [mm]	Ø372H8
Clamp Method	Hydraulic Max. 35bar
Allowable Work Inertia [kgm ²]	33.07
Clamp Torque [N · m]	4000
Max. Spindle Speed [mm ⁻¹]	25
Gear Ratio [mm]	1/120
Repeatability Accuracy [sec]	4
Indexing Accuracy [sec]	20
Weight [kg]	750
Servo Motor [FANUC]	αiF22 / 3000

Allowable load	Horizontal [kg]		1000
	Vertical [kg]		400
Allowable cutting load	F [kN]		70
	F x L [N·m]		10000
Allowable Cutting Torque	F x L [N·m]		4000
	[N·m]		5000

S-120,120L Controller type for NC Rotary Table



Application / Benefits

High Precision & High Speed Systems, Vertical & Horizontal available
 Compact Design, Extremely Rigid Body
 Realize High Clamping Force by applying Double Piston

Model No.

S-120 L

Motor Side
 Table Diameter
 TYPE : Single Spindle NC Rotary Table(Standard)

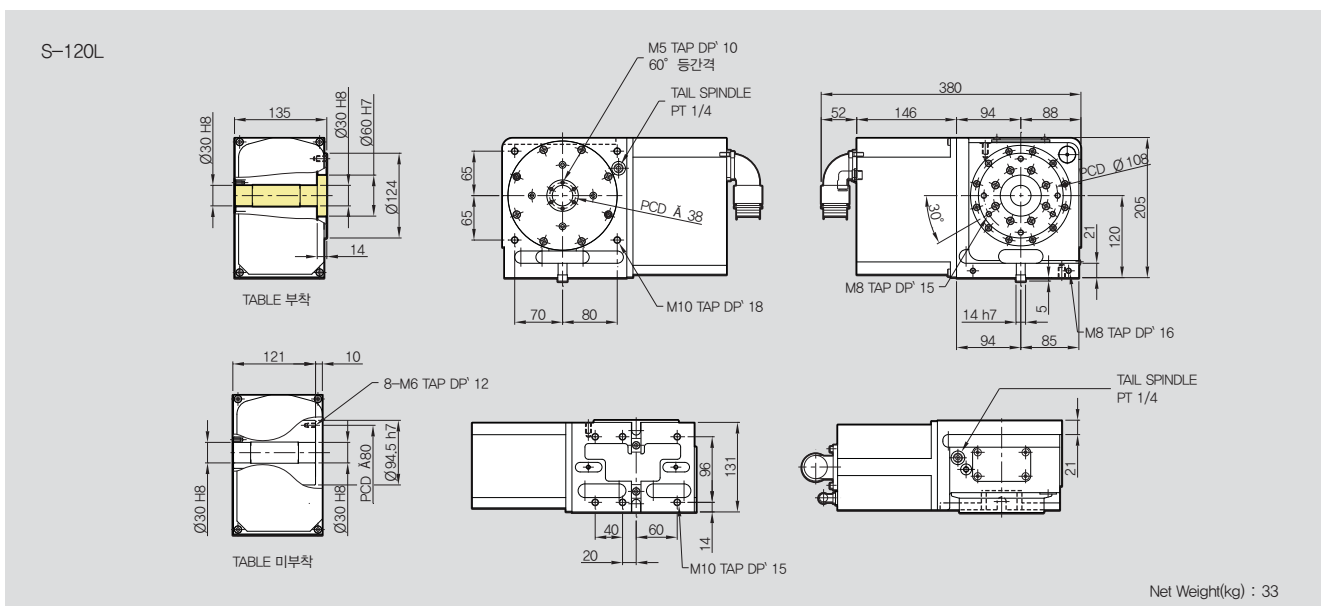
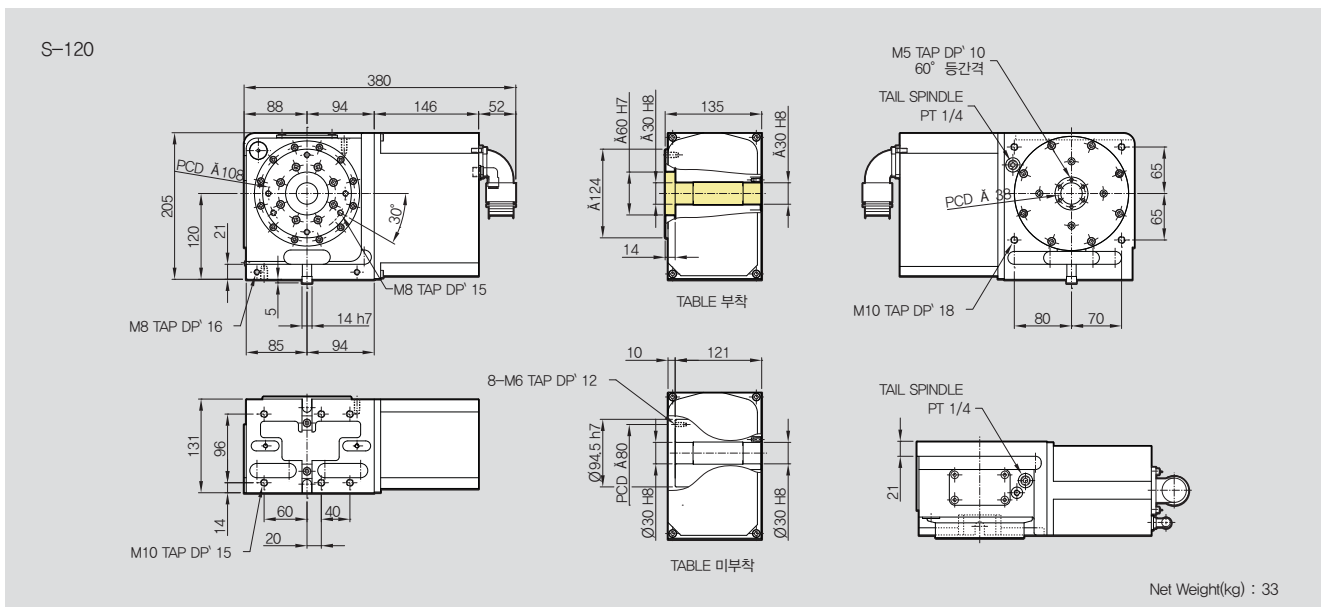

※ Product contents : The same with S-120F2(without servo motor)

S-170,170L

Controller type for NC Rotary Table



Application / Benefits

High Precision&High Speed Systems, Vertical & Horizontal available
Compact Design, Extremely Rigid Body
Realize High Clamping Force by applying Double Piston

Model No.

S-170 L

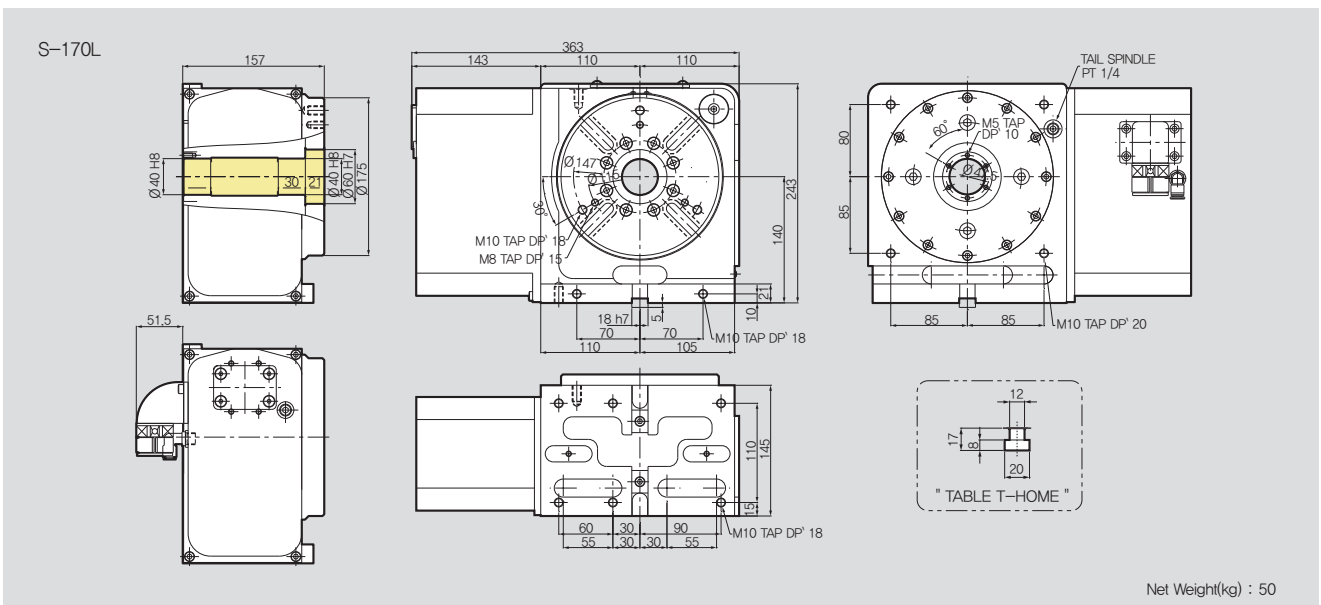
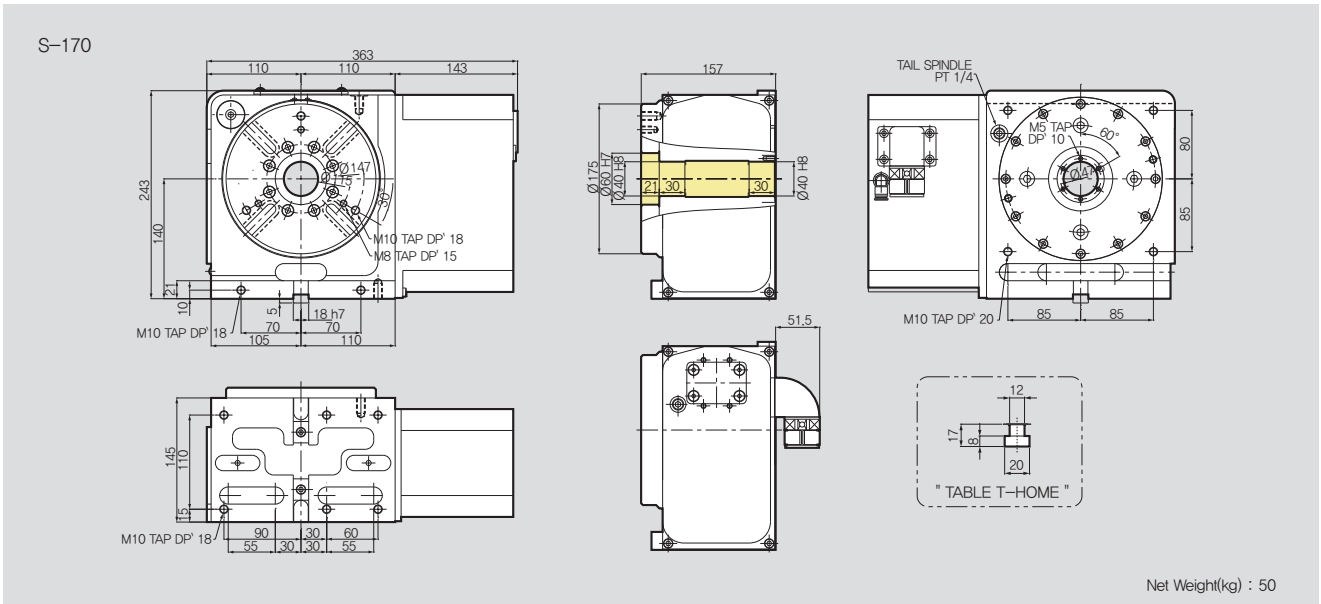
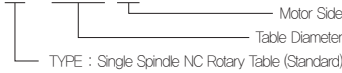

※Product contents : The same with S-170F2(without servo motor)

S-200,200L Controller type for NC Rotary Table



Application / Benefits

High Precision & High Speed Systems, Vertical & Horizontal available
 Compact Design, Extremely Rigid Body
 Realize High Clamping Force by applying Double Piston

Model No.

S-200 L

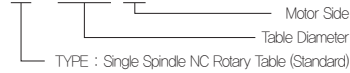

S-200

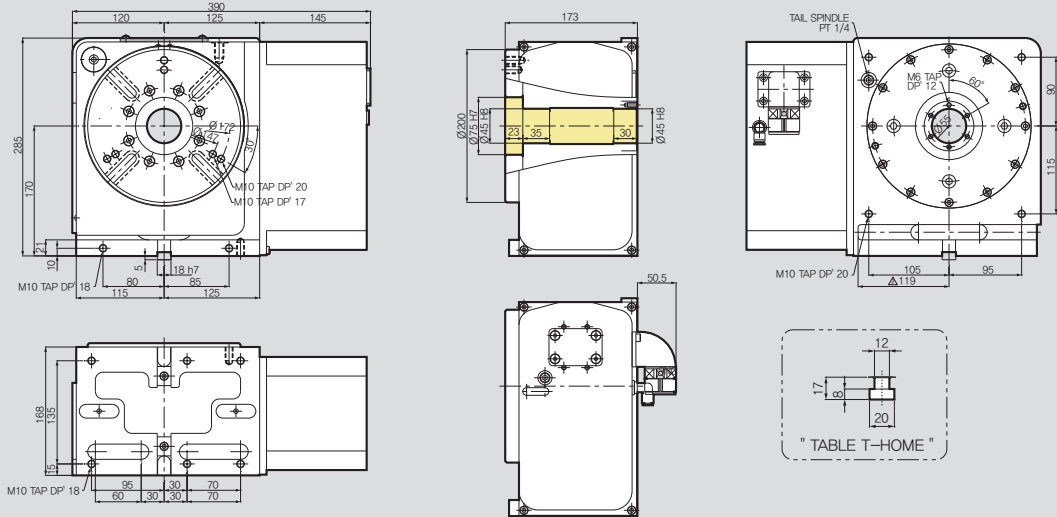

Net Weight(kg) : 71

S-200L

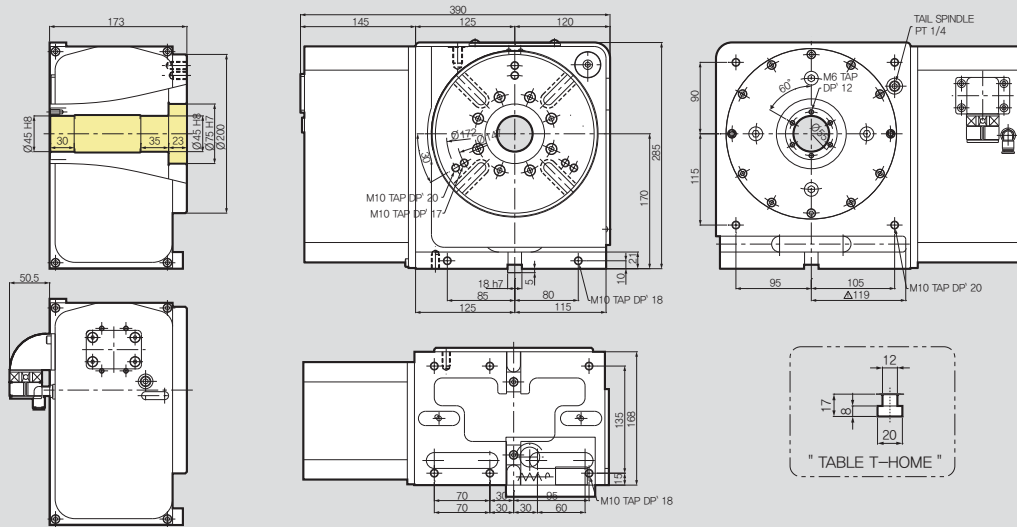

Net Weight(kg) : 71

※Product contents : The same with S-200F4(without servo motor)

S-250i, 250Li Controller type for NC Rotary Table



Application / Benefits

High Precision & High Speed Systems, Vertical & Horizontal available
 Compact Design, Extremely Rigid Body
 Realize High Clamping Force by applying Double Piston

Model No.

S-250 L i

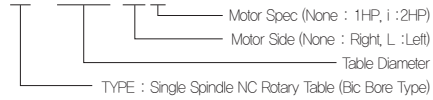

S-250i

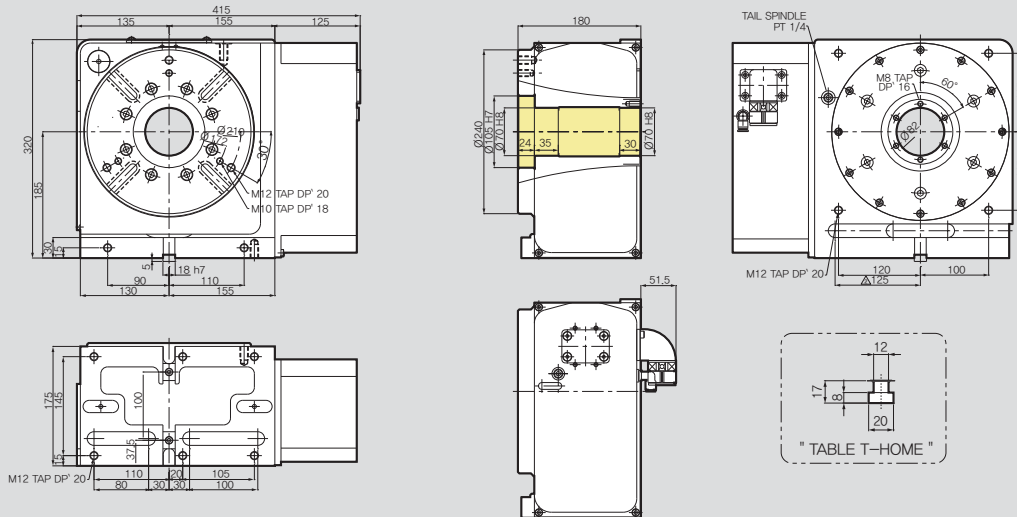

Net Weight(kg) : 91

S-250Li

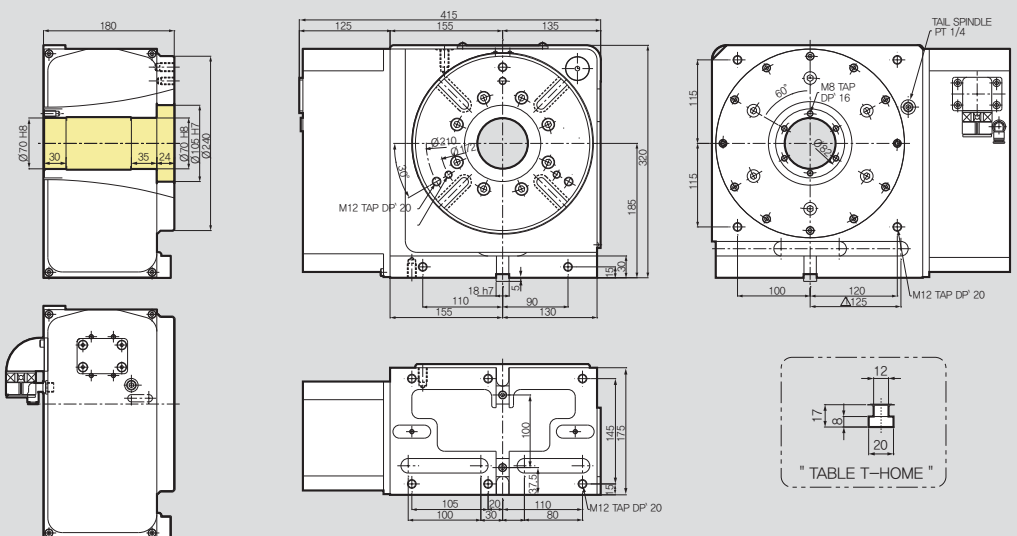

Net Weight(kg) : 91

※Product contents : The same with S-250F4(without servo motor)

S-320i, 320Li Controller type for NC Rotary Table



Application / Benefits

High Precision & High Speed Systems, Vertical & Horizontal available
 Compact Design, Extremely Rigid Body
 Realize High Clamping Force by applying Double Piston

Model No.

S-320 L i

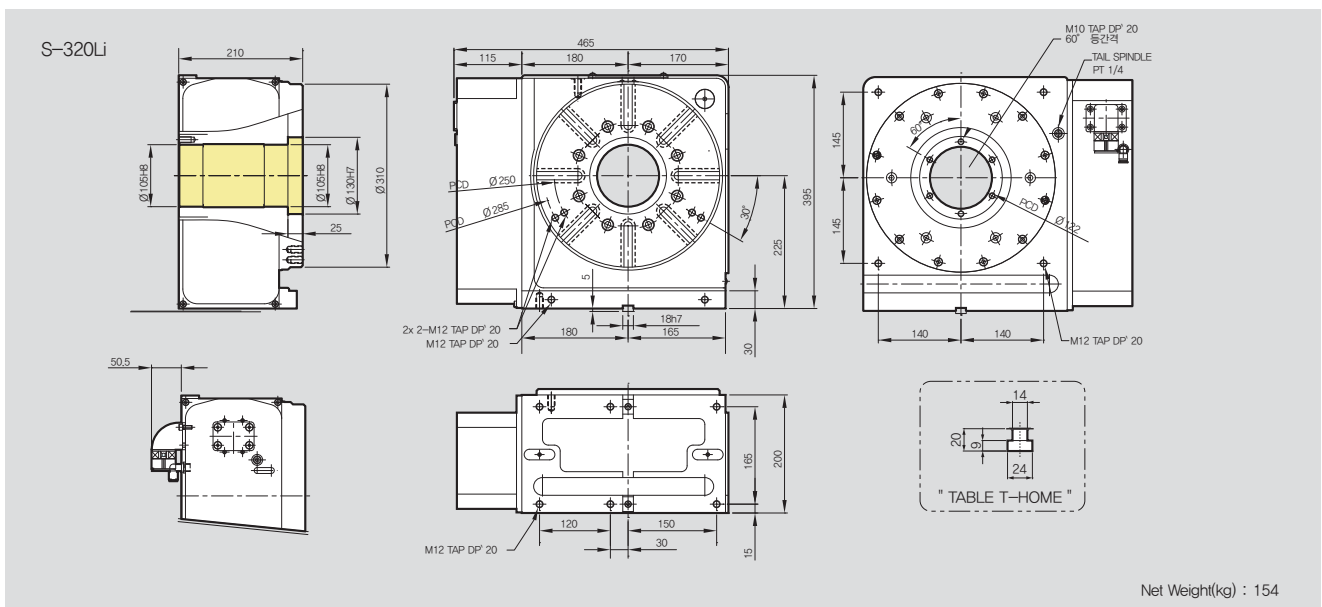
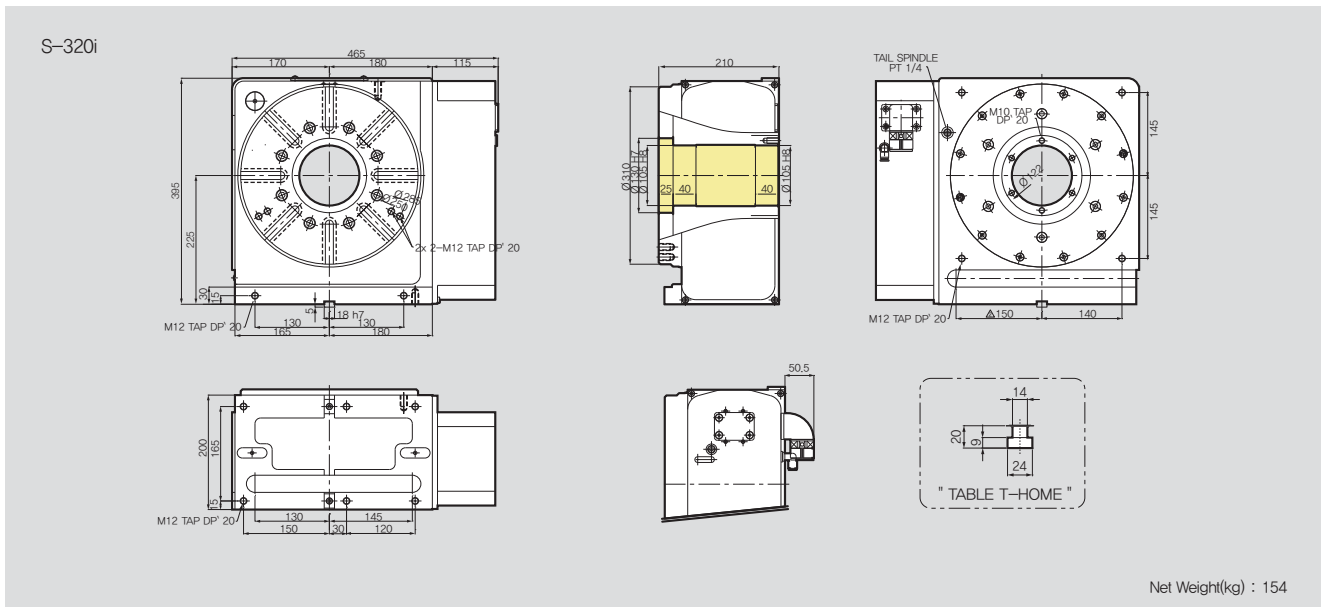
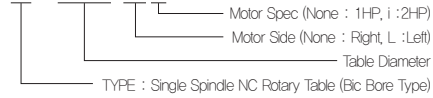

※Product contents : The same with S-320F8(without servo motor)

HRS-174F2 4th axis Hydraulic NC Rotary Table



Application / Benefits

High Precision & High Speed Systems, Vertical & Horizontal application
 Compact Design, Extremely Rigid Body
 High Clamping power (Hydraulic)

Model No.

HRS-174 F2

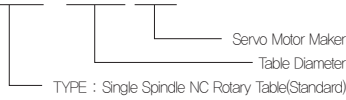

Servo Motor Maker

- | | |
|----------------|-----------------|
| F : FANUC | H : HEIDENHAIN |
| S : SIEMENS | L : LS MECAPION |
| M : MITSUBISHI | SY : SANYO |
| P : PANASONIC | FA : FAGOR |
| Y : YASKAWA | O : OKUMA |

HRS-174F4

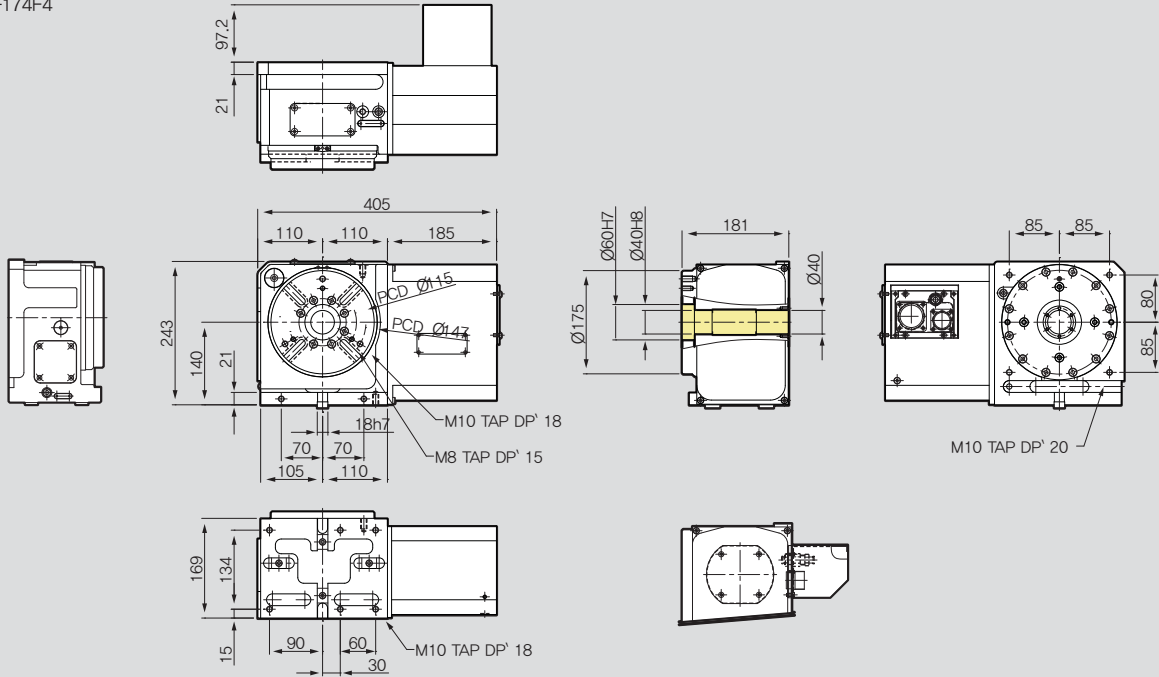

NC Rotary Table

SPECIFICATIONS

Table Dia. [mm]	Ø175
Center Height [mm]	140
Resister Dia. On Face Plate	Ø60H7
Spindle Through Hole Dia. [mm]	Ø40H8
Clamp Method	Hydraulic MAX. 35bar
Allowable Work Inertia [kgm ²]	0.51
Clamp Torque [N · m]	-
Max. Spindle Speed [mm ⁻¹]	69.4
Gear Ratio [mm]	1/72
Repeatability Accuracy [sec]	4
Indexing Accuracy [sec]	20
Weight [kg]	62
Servo Motor [FANUC]	aiF2 / 5000

Allowable load	Horizontal [kg]		160
	Vertical [kg]		80
Allowable cutting load	F x L [N·m]		10
	F x L [N·m]		600
Allowable Cutting Torque [N·m]	F x L [N·m]		380
	F x L [N·m]		220

HRS-204F4 4th axis Hydraulic NC Rotary Table



Application / Benefits

High Precision & High Speed Systems, Vertical & Horizontal available
 Compact Design, Extremely Rigid Body
 High Clamping power (Hydraulic)

Model No.

HRS-204 F4



Servo Motor Maker

- | | |
|----------------|-----------------|
| F : FANUC | H : HEIDENHAIN |
| S : SIEMENS | L : LS MECAPION |
| M : MITSUBISHI | SY : SANYO |
| P : PANASONIC | FA : FAGOR |
| Y : YASKAWA | O : OKUMA |

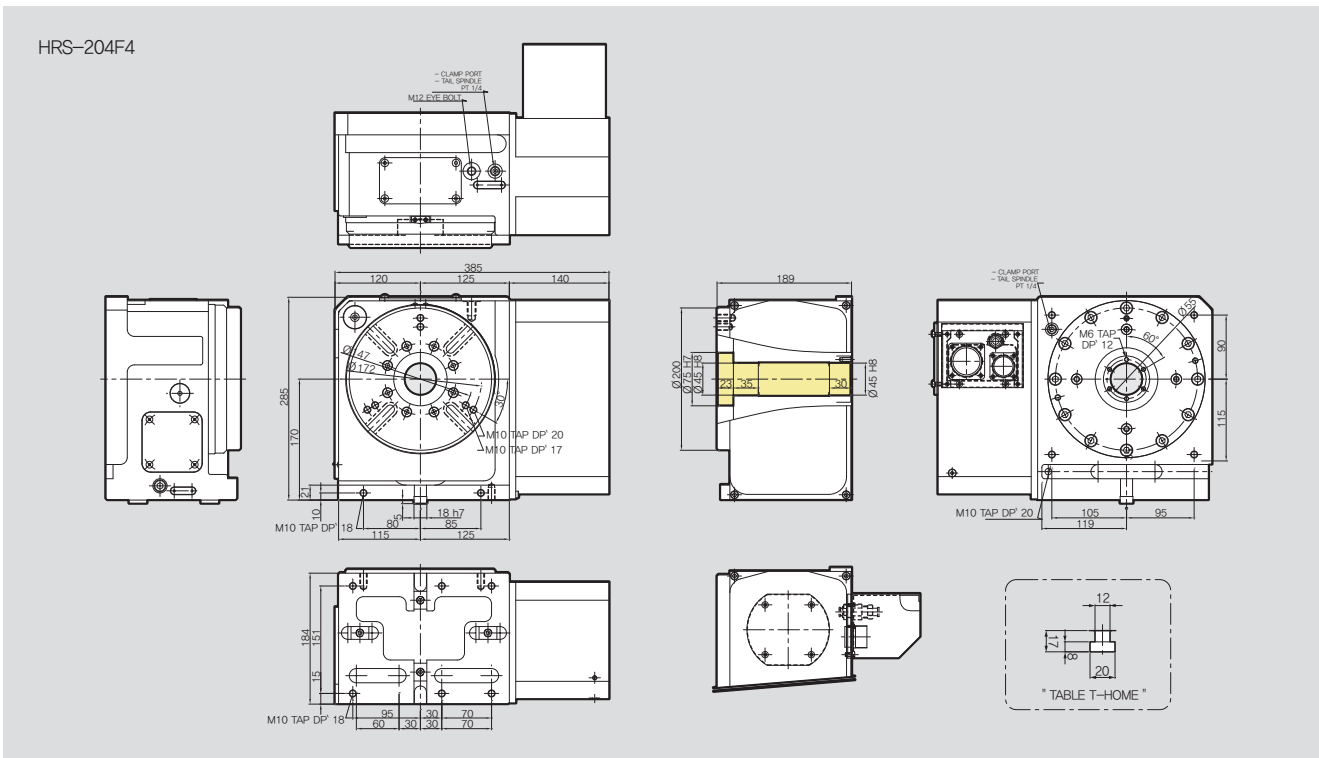

SPECIFICATIONS

Table Dia. [mm]	Ø210
Center Height [mm]	170
Resister Dia. On Face Plate	Ø75H7
Spindle Through Hole Dia. [mm]	Ø45H8
Clamp Method	Hydraulic MAX. 35bar
Allowable Work Inertia [kgm ²]	0.8
Clamp Torque [N · m]	720
Max. Spindle Speed [mm ⁻¹]	33.3
Gear Ratio [mm]	1/90
Repeatability Accuracy [sec]	4
Indexing Accuracy [sec]	20
Weight [kg]	79
Servo Motor [FANUC]	aiF4 / 4000

Allowable load	Horizontal [kg]		200
	Vertical [kg]		100
Allowable cutting load	F [kN]		17
	F x L [N-m]		1100
	F x L [N-m]		480
	Allowable Cutting Torque [N-m]		270

HRS-254F4 4th axis Hydraulic NC Rotary Table



Application / Benefits

High Precision & High Speed Systems, Vertical & Horizontal available
 Compact Design, Extremely Rigid Body
 High Clamping power (Hydraulic)

Model No.

HRS-254 F4

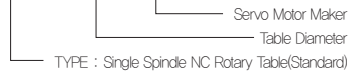

Servo Motor Maker

- | | |
|----------------|-----------------|
| F : FANUC | H : HEIDENHAIN |
| S : SIEMENS | L : LS MECAPION |
| M : MITSUBISHI | SY : SANYO |
| P : PANASONIC | FA : FAGOR |
| Y : YASKAWA | O : OKUMA |

HRS-254F4

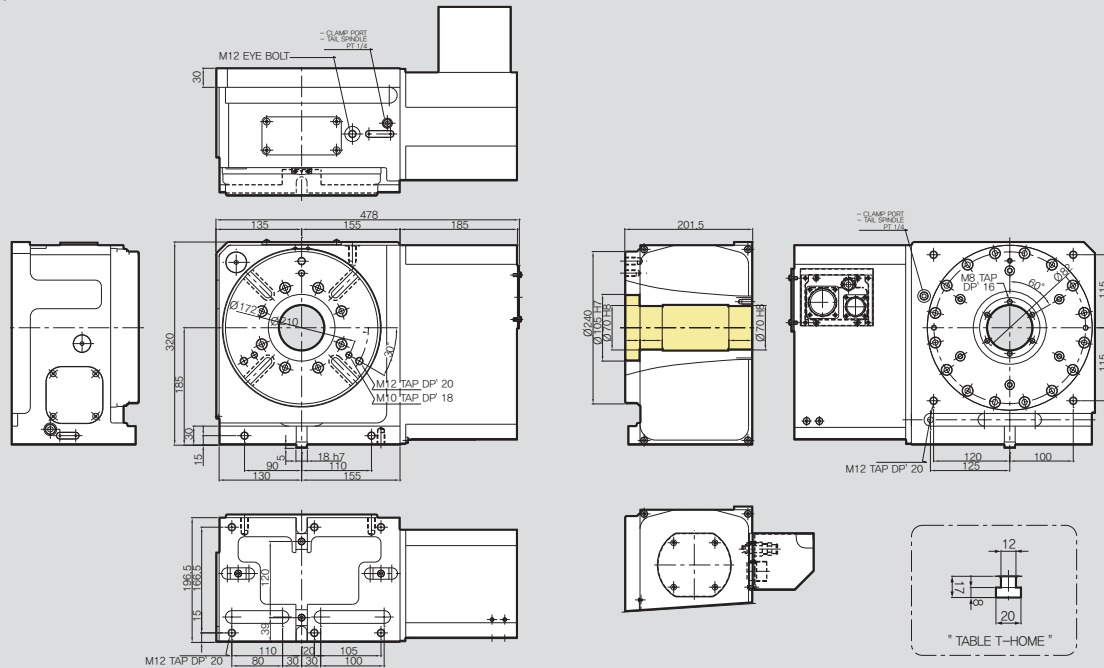

SPECIFICATIONS

Table Dia. [mm]	Ø240
Center Height [mm]	185
Resister Dia. On Face Plate	Ø105H7
Spindle Through Hole Dia. [mm]	Ø70H8
Clamp Method	Hydraulic MAX. 35bar
Allowable Work Inertia [kgm ²]	1.95
Clamp Torque [N · m]	1500
Max. Spindle Speed [mm ⁻¹]	33.3
Gear Ratio [mm]	1/90
Repeatability Accuracy [sec]	4
Indexing Accuracy [sec]	20
Weight [kg]	116
Servo Motor [FANUC]	αiF4 / 4000

Allowable load	Horizontal [kg]		250
	Vertical [kg]		125
Allowable cutting load	F [kN]		21
	F x L [N·m]		1600
Allowable Cutting Torque	F x L [N·m]		750
	[N·m]		480

HRS-254F8 4th axis Hydraulic NC Rotary Table



Application / Benefits

High Precision & High Speed Systems, Vertical & Horizontal available
 Compact Design, Extremely Rigid Body
 High Clamping power (Hydraulic)

Model No.

HRS-254 F8



Servo Motor Maker

- | | |
|----------------|-----------------|
| F : FANUC | H : HEIDENHAIN |
| S : SIEMENS | L : LS MECAPION |
| M : MITSUBISHI | SY : SANYO |
| P : PANASONIC | FA : FAGOR |
| Y : YASKAWA | O : OKUMA |

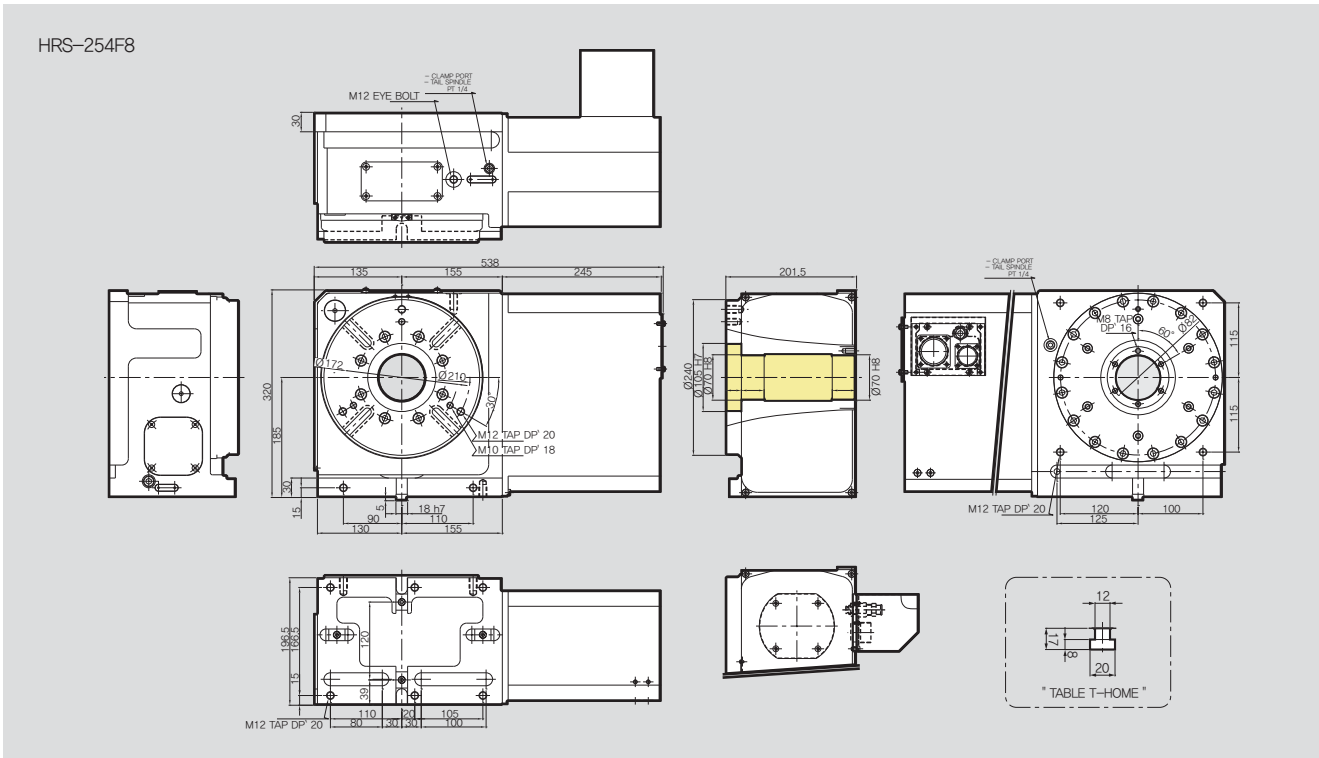

SPECIFICATIONS

Table Dia. [mm]	Ø240
Center Height [mm]	185
Resister Dia. On Face Plate	Ø105H7
Spindle Through Hole Dia. [mm]	Ø70H8
Clamp Method	Hydraulic MAX. 35 bar
Allowable Work Inertia [kgm ²]	3.12
Clamp Torque [N · m]	1500
Max. Spindle Speed [mm ⁻¹]	33.3
Gear Ratio [mm]	1/90
Repeatability Accuracy [sec]	4
Indexing Accuracy [sec]	20
Weight [kg]	116
Servo Motor [FANUC]	aiF8 / 3000

Allowable load	Horizontal [kg]		250
	Vertical [kg]		125
Allowable cutting load	F [kN]		21
	F x L [N·m]		1600
Allowable Cutting Torque [N·m]	F x L [N·m]		750
			600

HRS-324F8 4th axis Hydraulic NC Rotary Table



Application / Benefits

High Precision & High Speed Systems, Vertical & Horizontal available
 Compact Design, Extremely Rigid Body
 High Clamping power (Hydraulic)

Model No.

HRS-324 F8

— Servo Motor Maker
 — Table Diameter
 TYPE : Single Spindle NC Rotary Table (Standard)

Servo Motor Maker

F : FANUC H : HEIDENHAIN
 S : SIEMENS L : LS MECAPION
 M : MITSUBISHI SY : SANYO
 P : PANASONIC FA : FAGOR
 Y : YASKAWA O : OKUMA

HRS-324F8

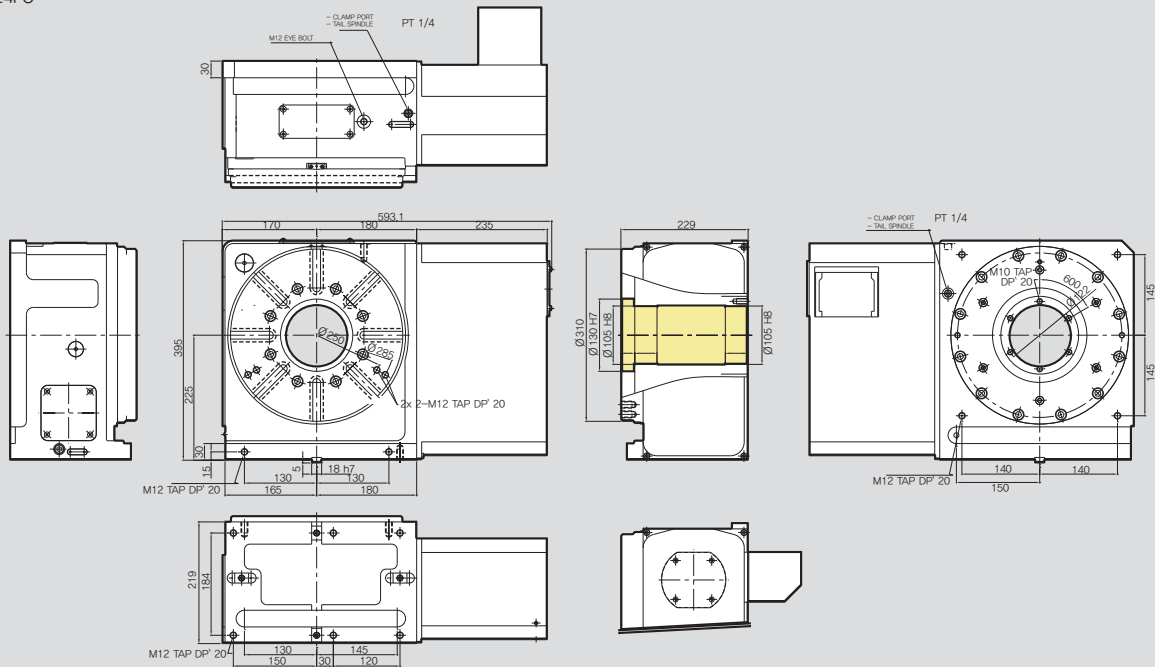

NC Rotary Table

SPECIFICATIONS

Table Dia. [mm]	Ø310
Center Height [mm]	225
Resister Dia. On Face Plate	Ø130H7
Spindle Through Hole Dia. [mm]	Ø105H8
Clamp Method	Hydraulic MAX. 35 bar
Allowable Work Inertia [kgm ²]	4.49
Clamp Torque [N · m]	2300
Max. Spindle Speed [mm ⁻¹]	25
Gear Ratio [mm]	1/120
Repeatability Accuracy [sec.]	4
Indexing Accuracy [sec.]	20
Weight [kg]	180
Servo Motor [FANUC]	αiF8 / 3000

Allowable load	Horizontal [kg]		350
	Vertical [kg]		180
Allowable cutting load	F [kN]		25
	F x L [N·m]		2400
Allowable Cutting Torque	F x L [N·m]		1440
	[N·m]		800

HRS-204, 254i

Controller type Hydraulic
NC Rotary Table



Application / Benefits

High Precision & High Speed Systems, Vertical & Horizontal available
Compact Design, Extremely Rigid Body
High Clamping power (Hydraulic)

Model No.

HRS-204

_____ Table Diameter
TYPE : Single Spindle NC Rotary Table (Standard)

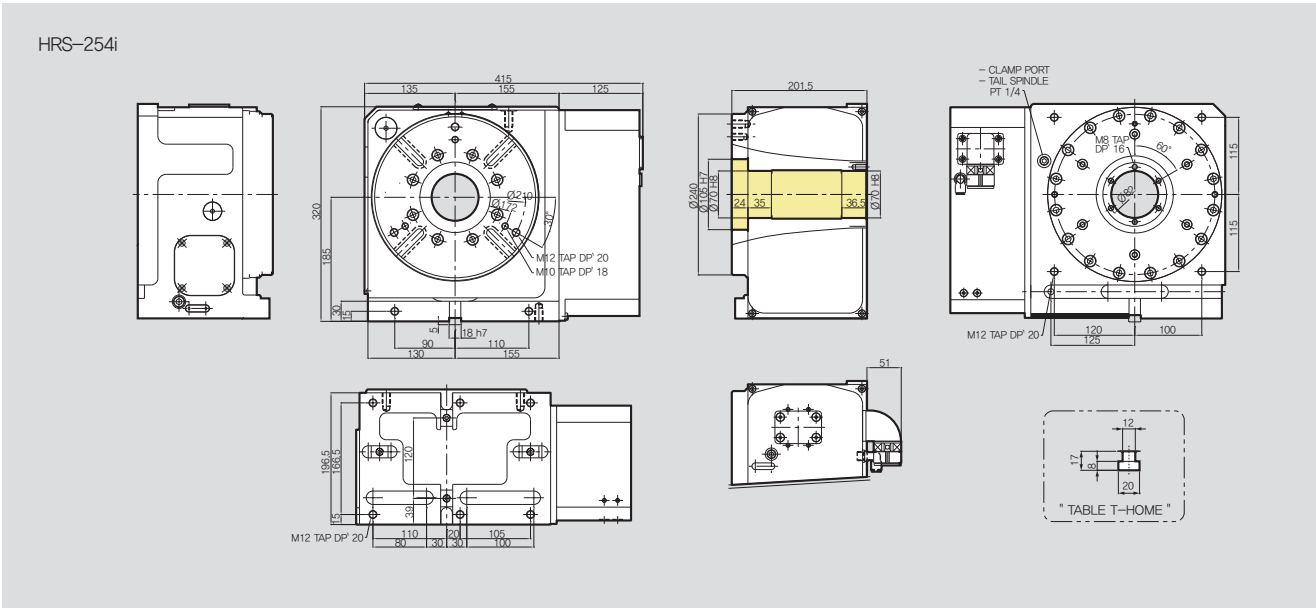
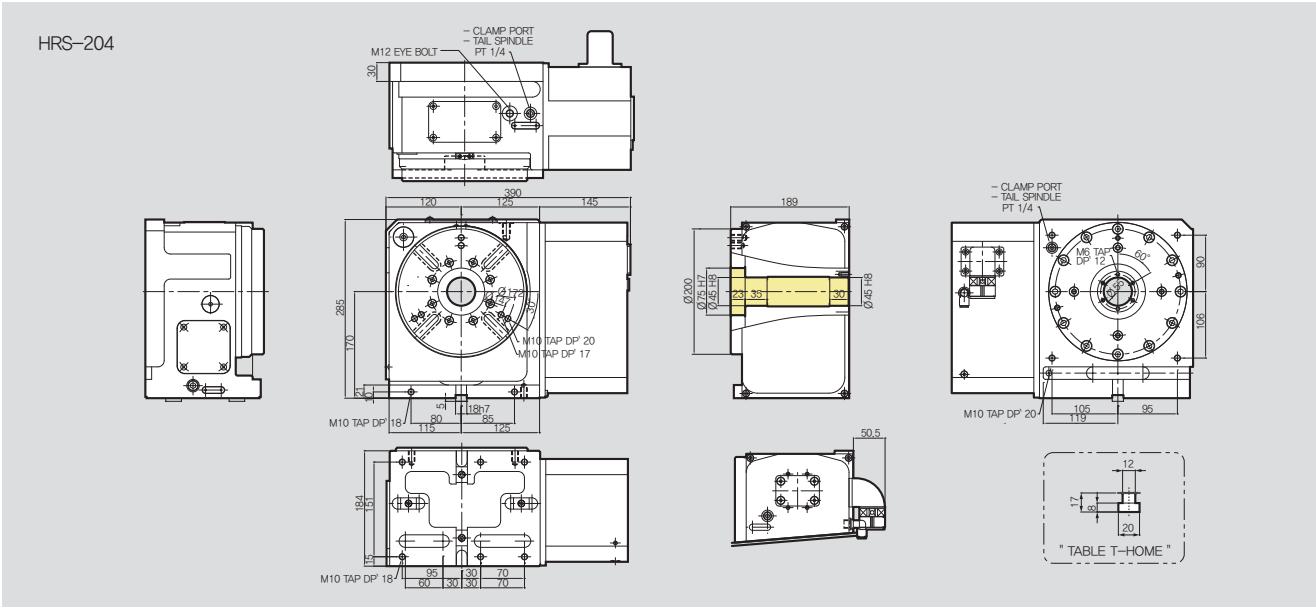

※ Product contents : The same with HRS-204F4 (without servo motor)

NC Rotary Table

HRS-324i Controller type Hydraulic NC Rotary Table



Application / Benefits

High Precision & High Speed Systems, Vertical & Horizontal available
 Compact Design, Extremely Rigid Body
 High Clamping power (Hydraulic)

Model No.

HRS-324 i

Motor Side (None : 1HP, i : 2HP)
 Table Diameter
 TYPE : Single Spindle NC Rotary Table (Standard)

HRS-324i

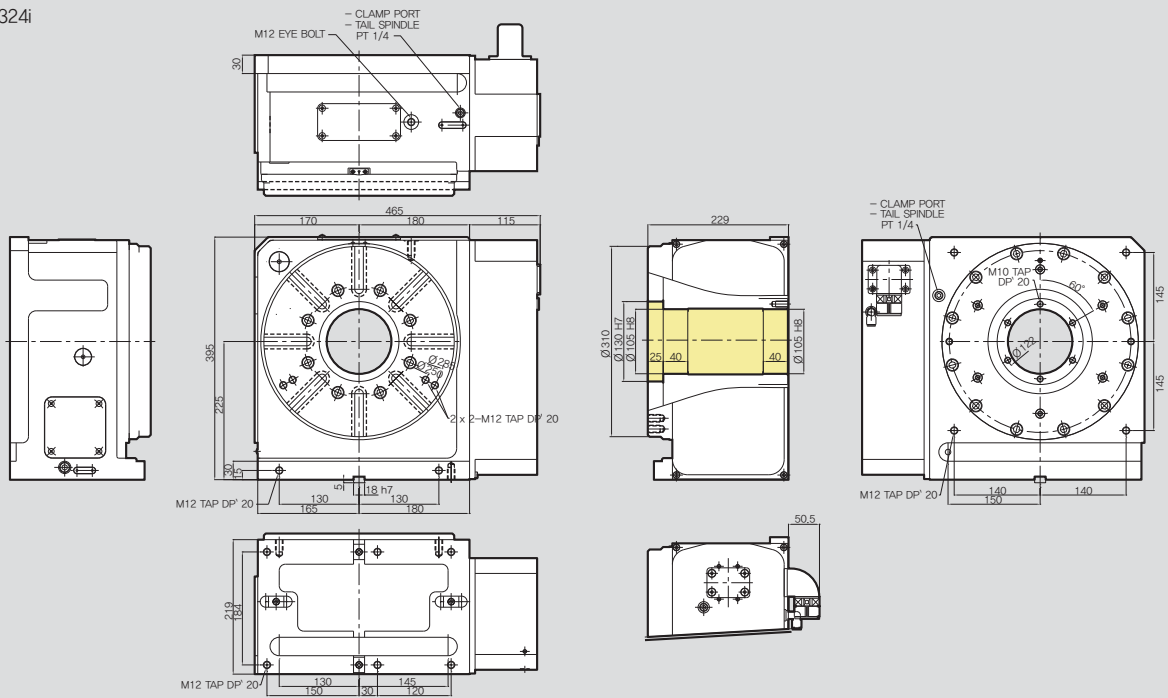

※Product contents : The same with HRS-324F8(without servo motor)

TR-120FF 4th, 5th axis for Tilting NC Rotary Table



Application / Benefits

Compact Tilting Series, High Precision&High Speed Systems
 Convenient JIG Design, Compact Design, Extremely Rigid Body
 High Clamping power (Hydraulic)

Model No.

TR-120 FF

— Servo Motor Maker
 — Table Diameter
 — TYPE : Tilting NC Rotary Table(Standard)

Servo Motor Maker

F : FANUC H : HEIDENHAIN
 S : SIEMENS L : LS MECAPION
 M : MITSUBISHI SY : SANYO
 P : PANASONIC FA : FAGOR
 Y : YASKAWA O : OKUMA

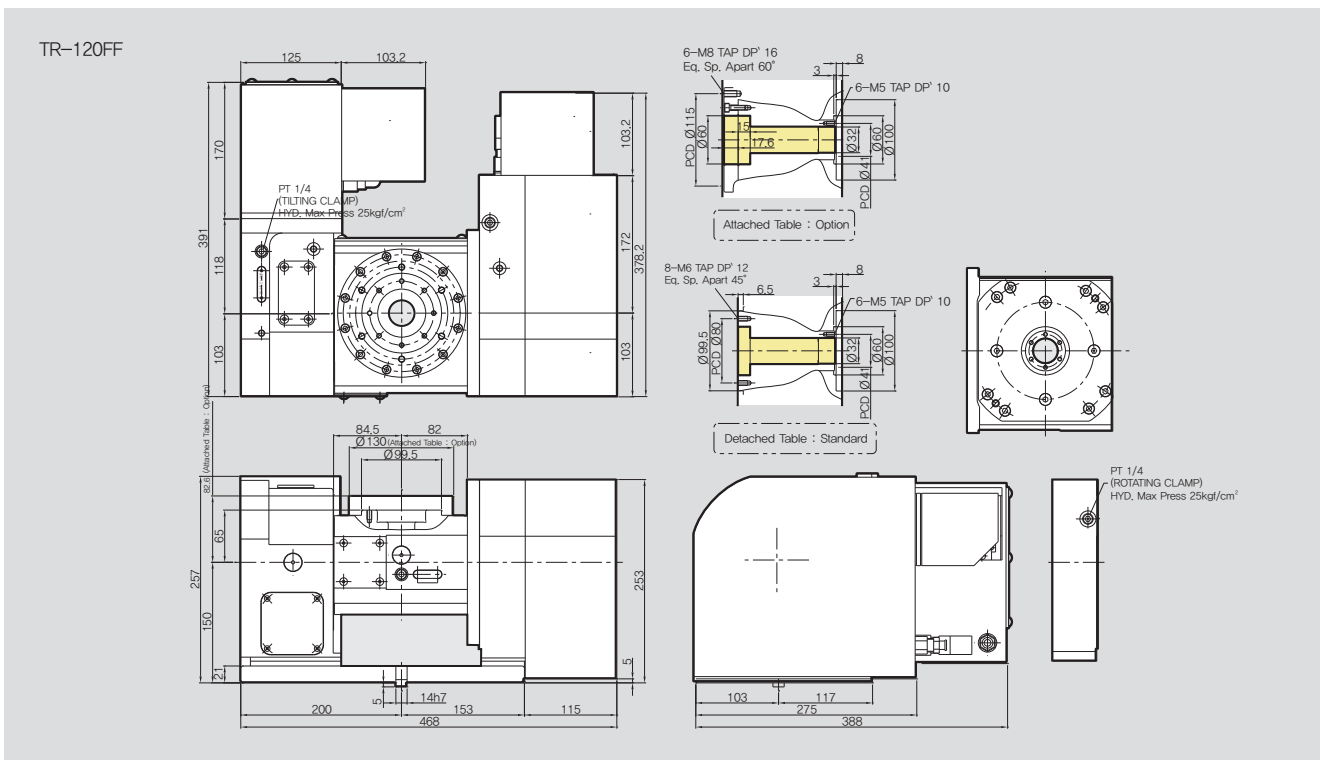

SPECIFICATIONS

Tilting Range: $-20^{\circ} \sim 110^{\circ}$

Table Dia. [mm]	Ø130	
Center Height [mm]	150	
Resister Dia. On Face Plate	Ø60H7	
Spindle Through Hole Dia. [mm]	Ø32H8	
Clamp Method	Hydraulic Max. 20bar	
Allowable Work Inertia [kgm ²]	0.06	
Weight [kg]	120	
	Rotating Axis	Tilting Axis
Max. Spindle Speed [mm ⁻¹]	33.3	16.6
Gear Ratio [mm]	1/90	1/180
Repeatability Accuracy [sec]	4	4
Indexing Accuracy [sec]	40	60
Clamp Torque [N · m]	200	300
Servo Motor [FANUC]	aiF2 / 5000	aiF2 / 5000

Allowable load	Horizontal [kg]		35
	Vertical [kg]		20
Allowable cutting load	F [kN]		4
	F x L [N·m]		380
Allowable Cutting Torque	F x L [N·m]		240
	[N·m]		190
Moment Of Tilting Weight	W x L [kgf·m]		10

TR-200FF 4th, 5th axis for Tilting NC Rotary Table



Application / Benefits

Compact Tilting Series, High Precision&High Speed Systems
 Convenient JIG Design, Compact Design, Extremely Rigid Body
 High Clamping power (Hydraulic)

Model No.

TR-200 FF

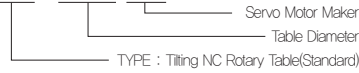

Servo Motor Maker

- | | |
|----------------|-----------------|
| F : FANUC | H : HEIDENHAIN |
| S : SIEMENS | L : LS MECAPION |
| M : MITSUBISHI | SY : SANYO |
| P : PANASONIC | FA : FAGOR |
| Y : YASKAWA | O : OKUMA |

TR-200FF

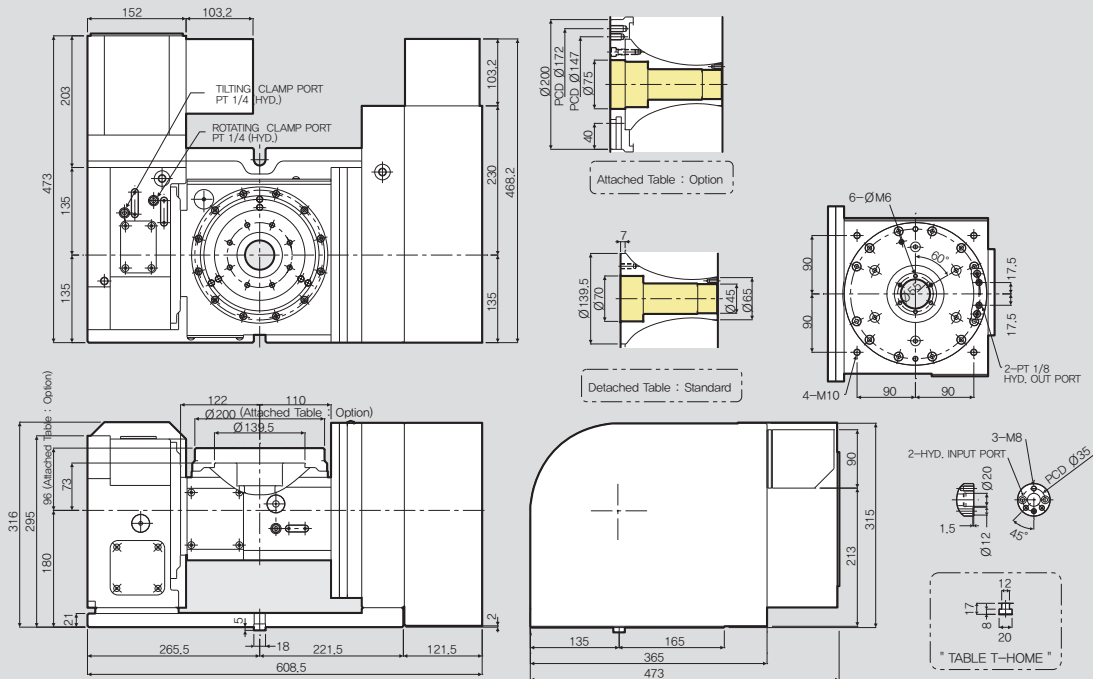

NC Rotary Table

SPECIFICATIONS

Tilting Range: $-20^{\circ} \sim 110^{\circ}$

Table Dia. [mm]	Ø200	
Center Height [mm]	180	
Resister Dia. On Face Plate	Ø70H7	
Spindle Through Hole Dia. [mm]	Ø45H8	
Clamp Method	Hydraulic Max. 35bar	
Allowable Work Inertia [kgm ²]	0.25	
Weight [kg]	250	
Max. Spindle Speed [mm ⁻¹]	Rotating Axis	Tilting Axis
	33.3	16.6
Gear Ratio [mm]	1/90	1/180
Repeatability Accuracy [sec]	4	4
Indexing Accuracy [sec]	30	60
Clamp Torque [N · m]	450	800
Servo Motor [FANUC]	aiF4 / 4000	aiF4 / 4000

Allowable load	Horizontal [kg]		60
	Vertical [kg]		40
Allowable cutting load	F [kN]		5
	F x L [N·m]		800
Allowable Cutting Torque	F x L [N·m]		450
	[N·m]		250
Moment Of Tilting Weight	W x L [kg·m]		12

TR-250FF 4th, 5th axis for Tilting NC Rotary Table



Application / Benefits

Tilting Series, High Precision&High Speed Systems, Convenient JIG Design
Extremely Rigid Body, High Clamping power (Hydraulic)

Model No.

TR-250 FF



Servo Motor Maker

- | | |
|----------------|-----------------|
| F : FANUC | H : HEIDENHAIN |
| S : SIEMENS | L : LS MECAPION |
| M : MITSUBISHI | SY : SANYO |
| P : PANASONIC | FA : FAGOR |
| Y : YASKAWA | O : OKUMA |

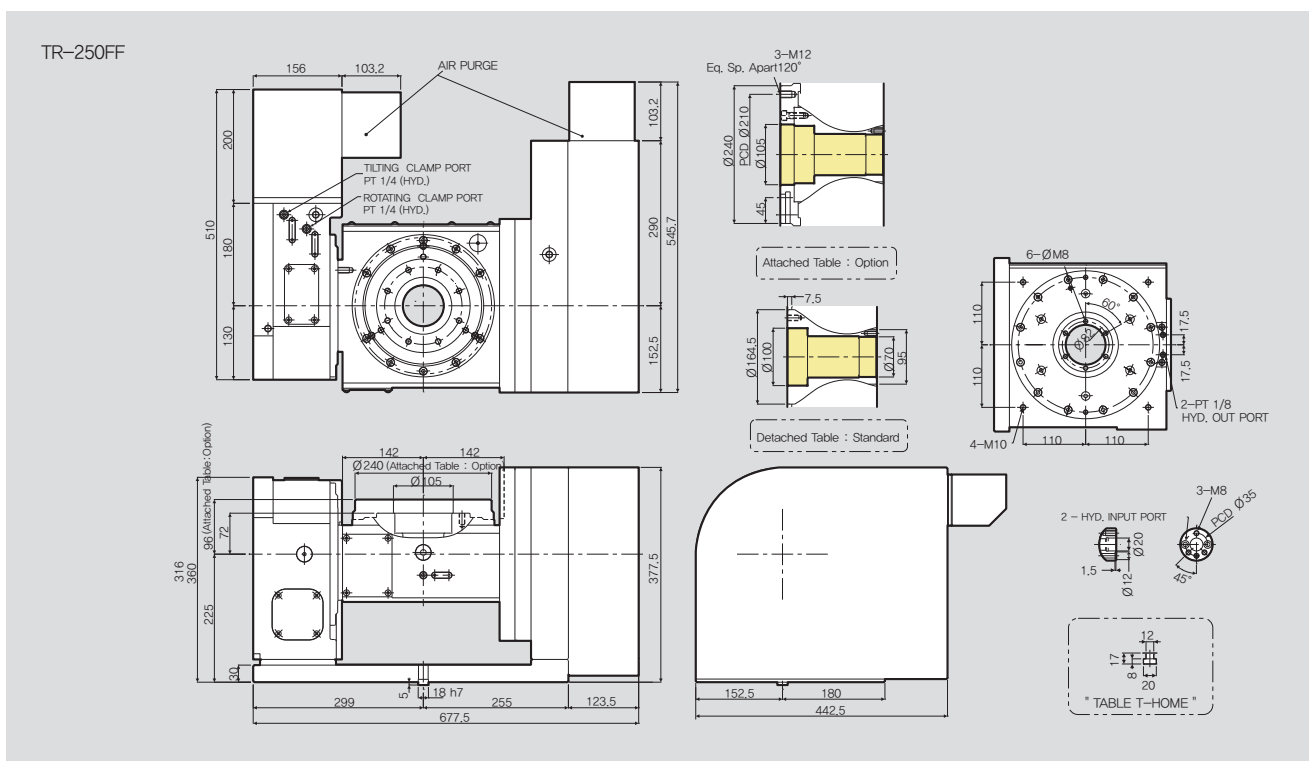

SPECIFICATIONS

Table Dia. [mm]	Ø240	
Center Height [mm]	225	
Resister Dia. On Face Plate	Ø100H7	
Spindle Through Hole Dia. [mm]	Ø70H8	
Clamp Method	Hydraulic Max. 35bar	
Allowable Work Inertia [kgm ²]	0.78	
Weight [kg]	295	
	Rotating Axis	Tilting Axis
Max. Spindle Speed [mm ⁻¹]	33.3	16.6
Gear Ratio [mm]	1/90	1/180
Repeatability Accuracy [sec]	4	4
Indexing Accuracy [sec]	30	60
Clamp Torque [N · m]	900	1200
Servo Motor [FANUC]	αiF4 / 4000	αiF4 / 4000

Tilting Range: -20° ~ 110°

Allowable load	Horizontal [kg]		100
	Vertical [kg]		60
Allowable cutting load	F [kN]		12
	F x L [N·m]		1200
Allowable Cutting Torque	F x L [N·m]		900
	[N·m]		600
Moment Of Tilting Weight	W x L [kgf·m]		26

NC Rotary Table

TR-320FF 4th, 5th axis for Tilting NC Rotary Table



Application / Benefits

Tilting Series, High Precision&High Speed Systems, Convenient JIG Design
Extremely Rigid Body, High Clamping power (Hydraulic)

Model No.

TR-320 FF

— Servo Motor Maker
— Table Diameter
— TYPE : Tilting NC Rotary Table(Standard)

Servo Motor Maker

F : FANUC H : HEIDENHAIN
S : SIEMENS L : LS MECAPION
M : MITSUBISHI SY : SANYO
P : PANASONIC FA : FAGOR
Y : YASKAWA O : OKUMA

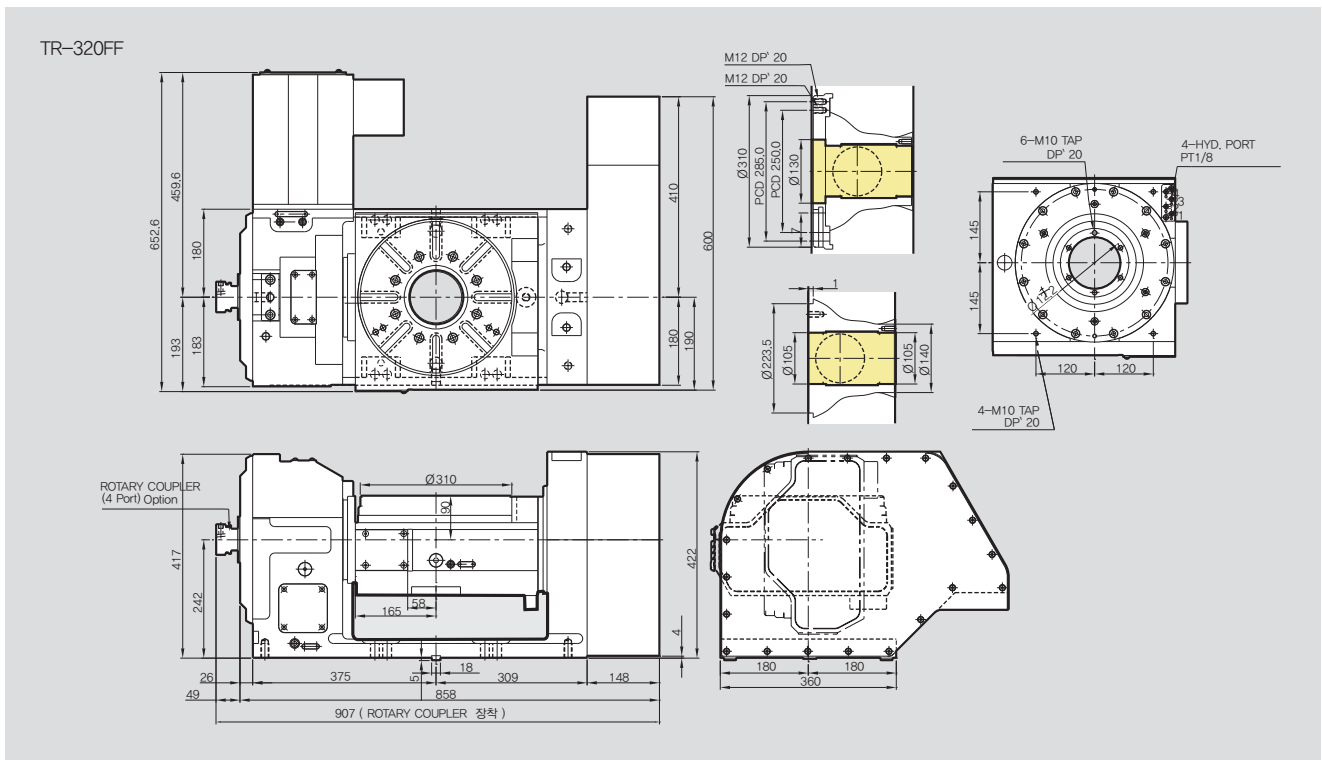

SPECIFICATIONS

Tilting Range: $-20^{\circ} \sim 110^{\circ}$

Table Dia. [mm]	Ø320	
Center Height [mm]	242	
Resister Dia. On Face Plate	Ø130H7	
Spindle Through Hole Dia. [mm]	Ø105H8	
Clamp Method	Hydraulic Max. 35bar	
Allowable Work Inertia [kgm ²]	-	
Weight [kg]	410	
	Rotating Axis	Tilting Axis
Max. Spindle Speed [mm ⁻¹]	25	25
Gear Ratio [mm]	1/120	1/120
Repeatability Accuracy [sec]	4	8
Indexing Accuracy [sec]	30	60
Clamp Torque [N · m]	2300	2600
Servo Motor [FANUC]	aiF8 / 3000	aiF12 / 3000

Allowable load	Horizontal [kg]		150
	Vertical [kg]		100
Allowable cutting load	F [kN]		13.5
	F x L [N·m]		2600
Allowable Cutting Torque	F x L [N·m]		2300
	[N·m]		800
Moment Of Tilting Weight	W x L [kg·m]		-

TR-120, 200i Controller type for Tilting NC Rotary Table



Application / Benefits

Tilting Series, High Precision&High Speed Systems, Convenient JIG Design
Compact Design, Extremely Rigid Body

Model No.

TR-120

Table Diameter
TYPE : Tilting NC Rotary Table

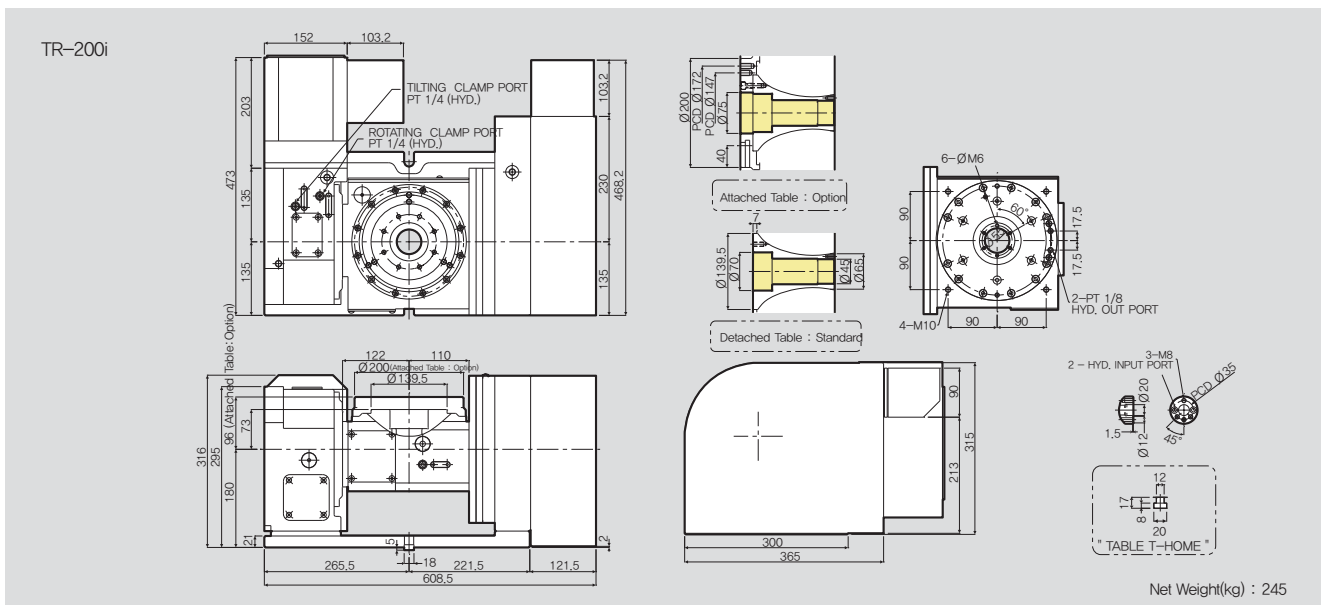
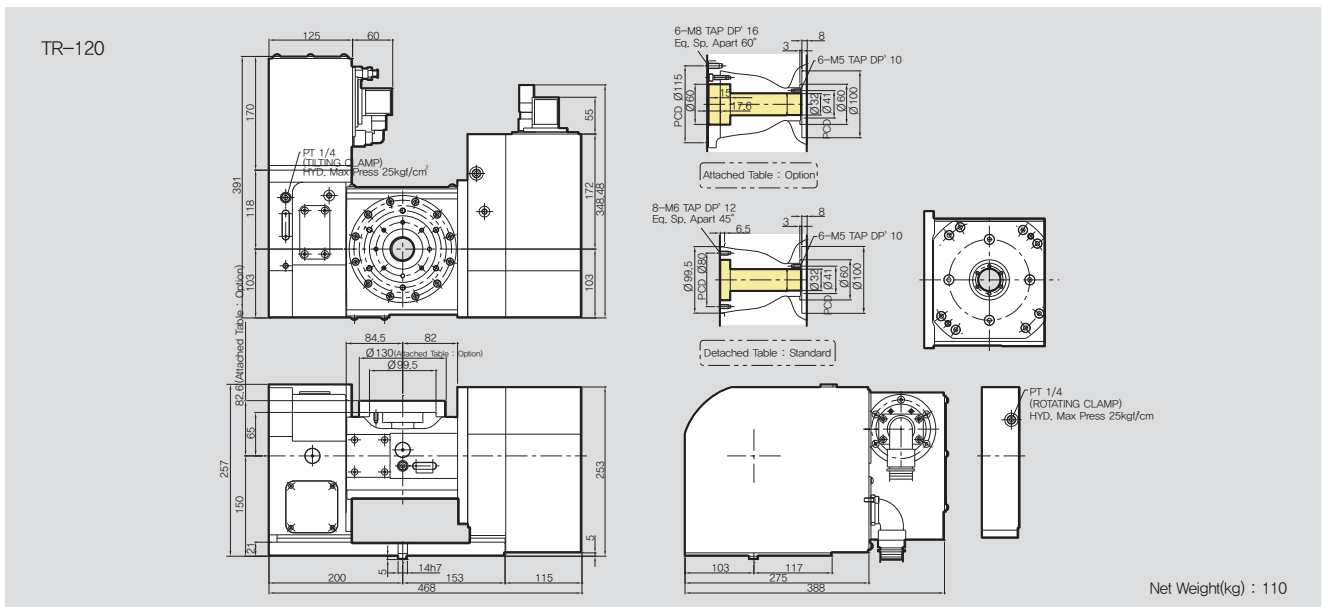

※Product contents : The same with TR-120FF(without servo motor)

TR-250i

Controller type for Tilting NC Rotary Table



Application / Benefits

Tilting Series, High Precision&High Speed Systems, Convenient JIG Design
Extremely Rigid Body, High Clamping power (Hydraulic)

Model No.

TR-250 i

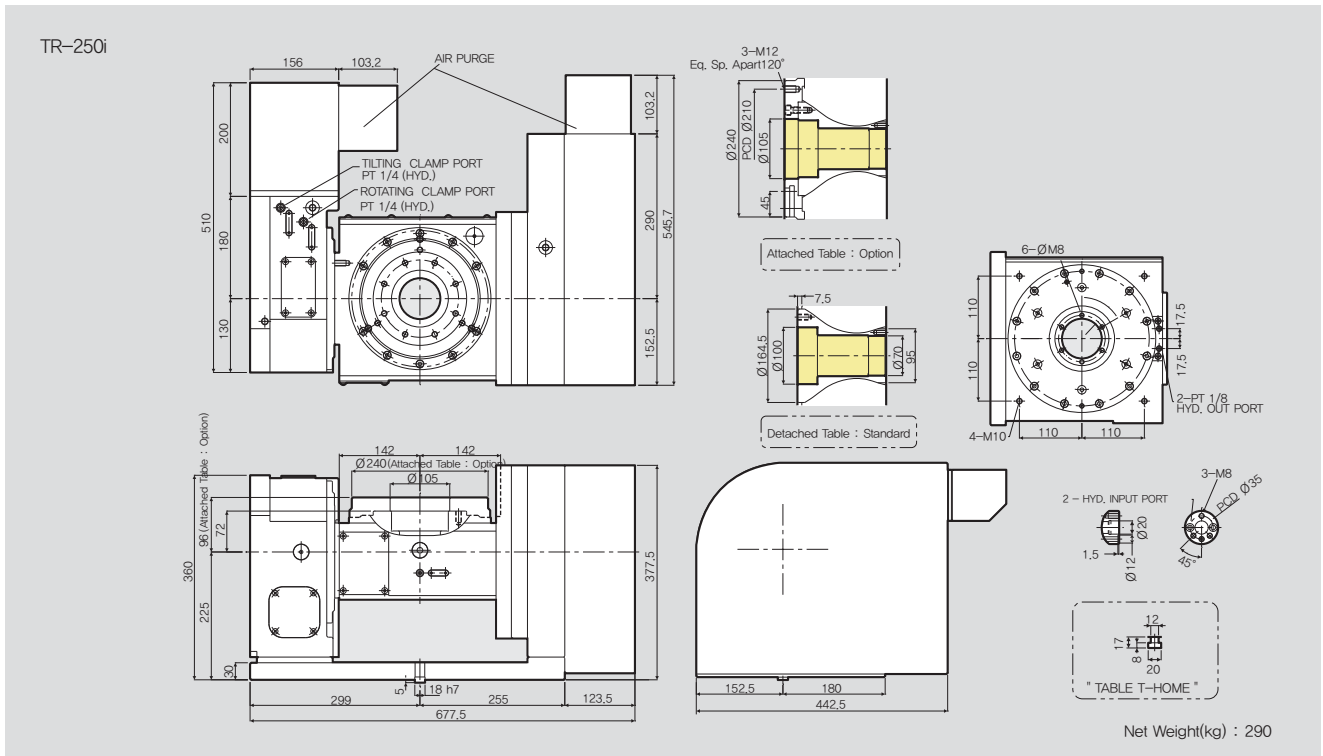
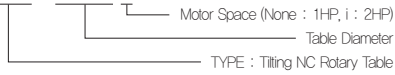

※Product contents : The same with TR-250FF(without servo motor)

MTR2-17432ii

Controller type for Multi Spindle
Tilting NC Rotary Table



Application / Benefits

Multi Spindle Tilting Series, High Precision&High Speed Systems
Convenient JIG Design, Extremely Rigid Body, High Clamping power (Hydraulic)

Model No.

MTR2-174 32ii



Servo Motor Maker

- | | |
|----------------|-----------------|
| F : FANUC | H : HEIDENHAIN |
| S : SIEMENS | L : LS MECAPION |
| M : MITSUBISHI | SY : SANYO |
| P : PANASONIC | FA : FAGOR |
| Y : YASKAWA | O : OKUMA |

MTR2-17432ii

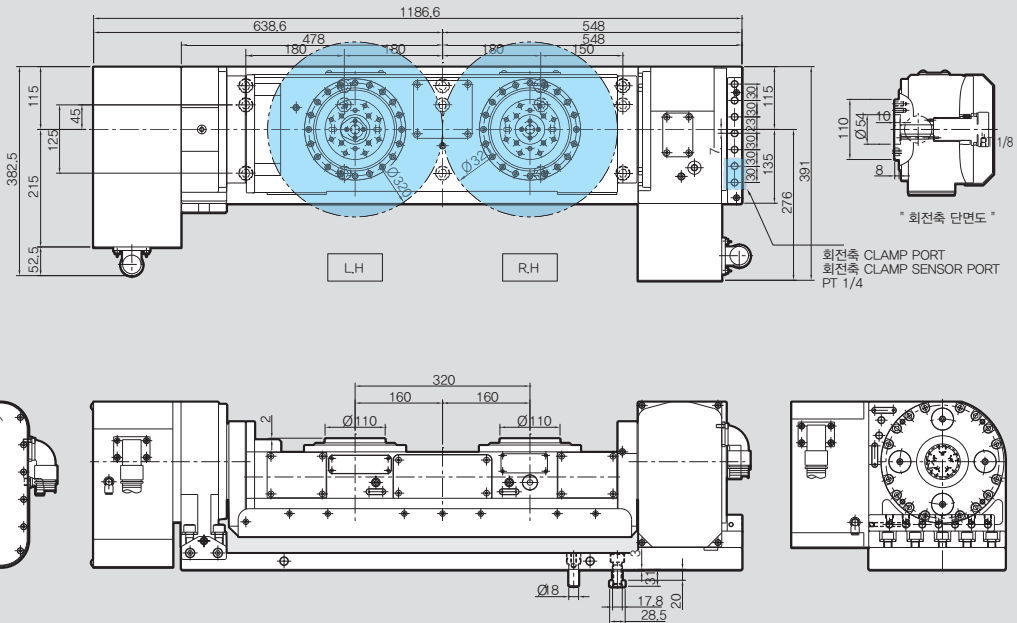

SPECIFICATIONS

Tilting Range: $-20^{\circ} \sim 120^{\circ}$

Table Dia. [mm]	Ø110	
Center Height [mm]	240	
Resister Dia. On Face Plate	Ø54 (Ø110)	
Distance between spindles [mm]	320	
Clamp Method	Hydraulic Max. 35 bar	
Allowable Work Inertia [kgm ²]	-	
Weight [kg]	295	
	Rotating Axis	Tilting Axis
Max. Spindle Speed [mm ⁻¹]	25	25
Gear Ratio [mm]	1/120	1/120
Repeatability Accuracy [sec]	4	4
Indexing Accuracy [sec]	40	60
Clamp Torque [N · m]	600	900
Servo Motor [FANUC]	SGMPS-15A2A6S	SGMPS-15A2A6S

Allowable load	Horizontal [kg]		40, 40
	Vertical [kg]		40, 40
Allowable cutting load	F [kN]		4
	F x L [N·m]		900
Allowable Cutting Torque	F x L [N·m]		600
	[N·m]		160

MTR2-20435ii, 20435FF

5th axis for Multi Spindle
Tilting NC Rotary Table



Application / Benefits

Multi Spindle Tilting Series, High Precision&High Speed Systems
Convenient JIG Design, Extremely Rigid Body, High Clamping power (Hydraulic)

Model No.

MTR2-204 35FF

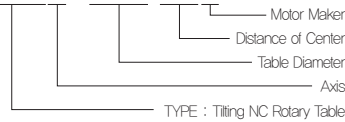

Servo Motor Maker

- F : FANUC H : HEIDENHAIN
- S : SIEMENS L : LS MECAPION
- M : MITSUBISHI SY : SANYO
- P : PANASONIC FA : FAGOR
- Y : YASKAWA O : OKUMA

MTR2-20435FF

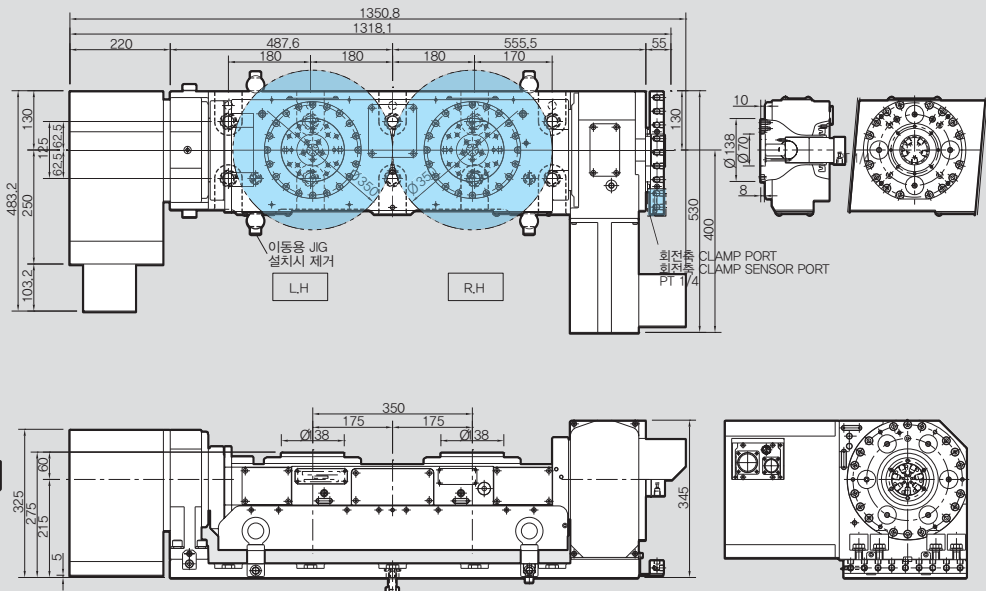

NC Rotary Table

SPECIFICATIONS

Tilting Range: $-20^{\circ} \sim 120^{\circ}$

Table Dia. [mm]	Ø138	
Center Height [mm]	275	
Resister Dia. On Face Plate	Ø70 (Ø138)	
Distance between spindles [mm]	350	
Clamp Method	Hydraulic Max. 35 bar	
Allowable Work Inertia [kgm ²]	-	
Weight [kg]	360	
Max. Spindle Speed [mm ⁻¹]	Rotating Axis	Tilting Axis
	25	25
Gear Ratio [mm]	1/120	1/120
Repeatability Accuracy [sec]	4	4
Indexing Accuracy [sec]	40	60
Clamp Torque [N · m]	800	1200
Servo Motor [FANUC]	aiF4 / 4000	aiF8 / 3000

Allowable load	Horizontal [kg]		50, 50
	Vertical [kg]		50, 50
Allowable cutting load	F [kN]		5
	F x L [N·m]		1200
	F x L [N·m]		800
Allowable Cutting Torque [N·m]			180

MTR2-25440ii,25440FF

5th axis for Multi Spindle
Tilting NC Rotary Table



Application / Benefits

Multi Spindle Tilting Series, High Precision&High Speed Systems
Convenient JIG Design, Extremely Rigid Body, High Clamping power (Hydraulic)

Model No.

MTR2-254 40FF

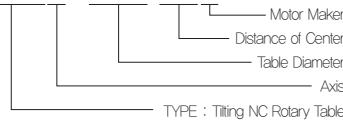

Servo Motor Maker

F : FANUC	H : HEIDENHAIN
S : SIEMENS	L : LS MECAPION
M : MITSUBISHI	SY : SANYO
P : PANASONIC	FA : FAGOR
Y : YASKAWA	O : OKUMA

MTR2-25440FF

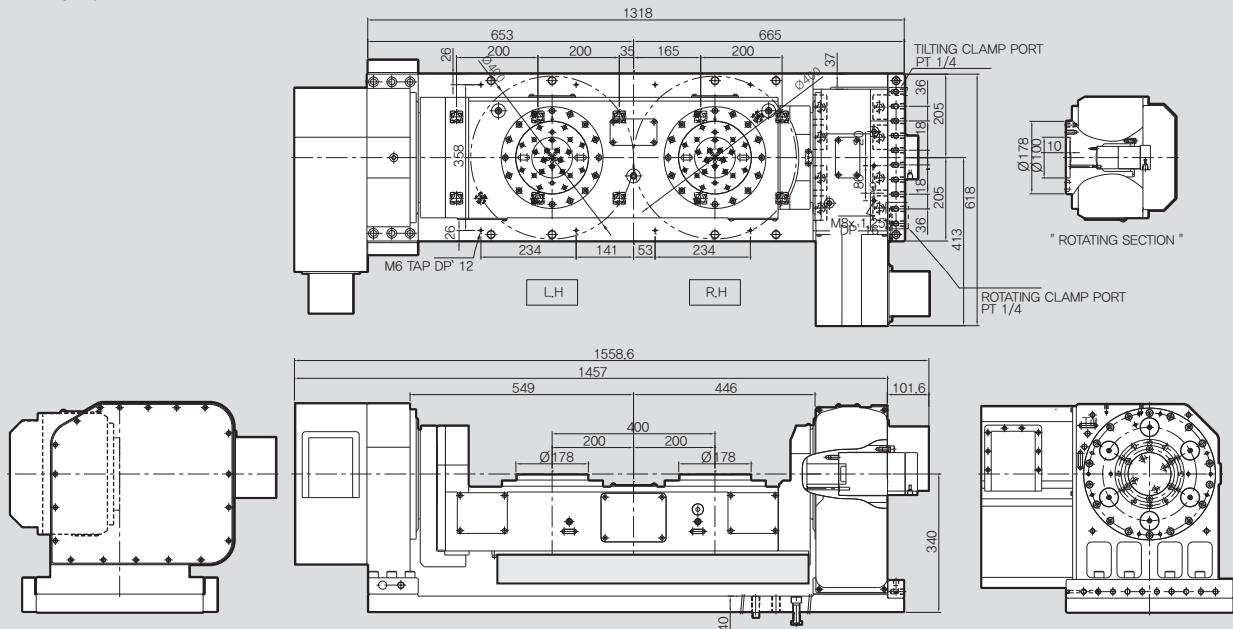

NC Rotary Table

SPECIFICATIONS

Tilting Range: $-20^{\circ} \sim 120^{\circ}$

Table Dia. [mm]	Ø178	
Center Height [mm]	340	
Resister Dia. On Face Plate	Ø100 (178)	
Distance between spindles [mm]	Ø400	
Clamp Method	Hydraulic Max. 35bar	
Allowable Work Inertia [kgm ²]	0.78	
Weight [kg]	890	
	Rotating Axis	Tilting Axis
Max. Spindle Speed [mm ⁻¹]	25	25
Gear Ratio [mm]	1/120	1/120
Repeatability Accuracy [sec]	4	4
Indexing Accuracy [sec]	40	60
Clamp Torque [N · m]	1600	2600
Servo Motor [FANUC]	αiF4 / 3000	αiF8 / 3000

Allowable load	Horizontal [kg]		100, 100
	Vertical [kg]		60, 60
Allowable cutting load	F [kN]		12
	F x L [N-m]		2600
	F x L [N-m]		1600
Allowable Cutting Torque	[N-m]		800

MS2-170F4 4th axis type for Multi Spindle NC Rotary Table



Application / Benefits

Doubles production output, Ideal for balanced workpieces
Realize High Clamping Force by applying Double Piston

Model No.

MS2-170F4

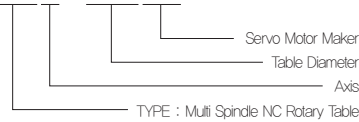





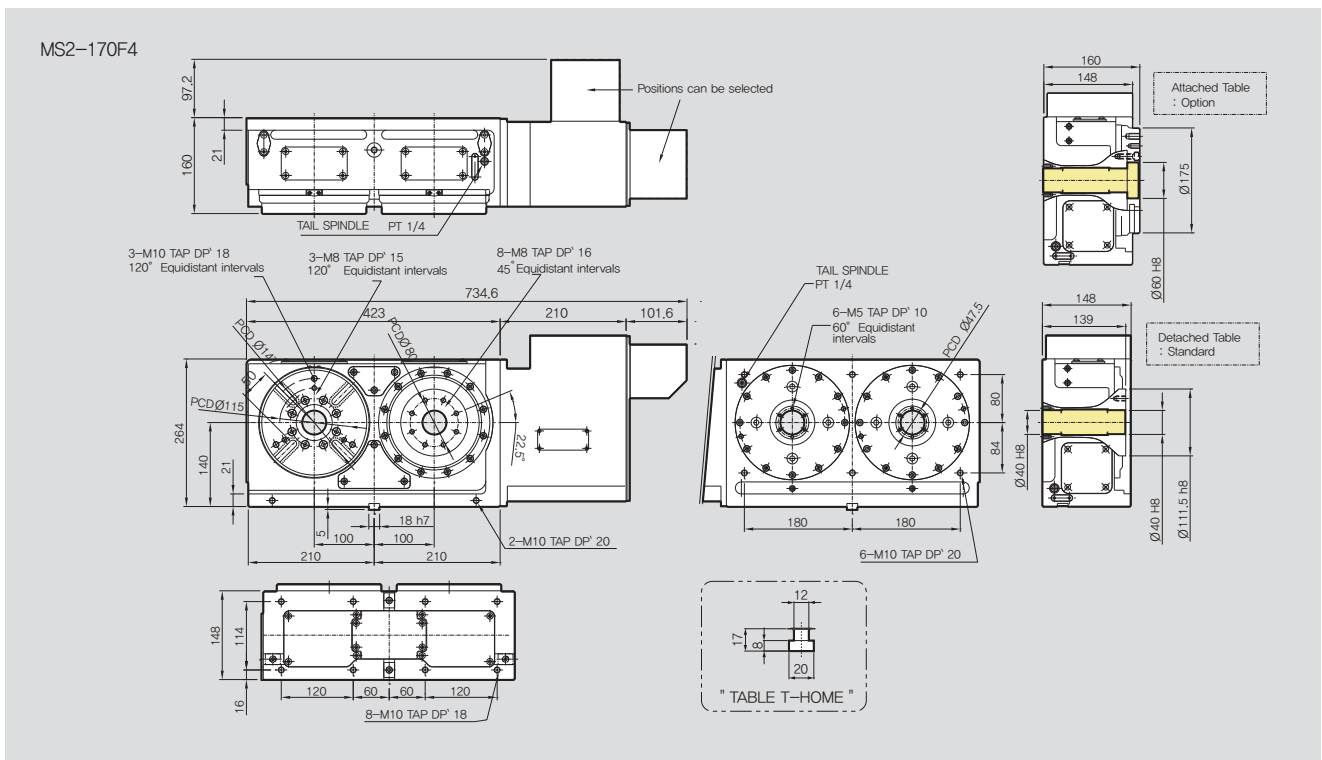

Servo Motor Maker

F : FANUC	H : HEIDENHAIN
S : SIEMENS	L : LS MECAPION
M : MITSUBISHI	SY : SANYO
P : PANASONIC	FA : FAGOR
Y : YASKAWA	O : OKUMA



SPECIFICATIONS

Table Dia. [mm]	(Table: Option) Ø175
Center Height [mm]	140
Resister Dia. On Face Plate	Ø60H8
Spindle Through Hole Dia. [mm]	Ø40H8
Clamp Method	Pneumatic
Allowable Work Inertia [kgm ²]	0.51
Clamp Torque [N · m]	380
Max. Spindle Speed [mm ⁻¹]	44.4
Gear Ratio [mm]	1/90
Repeatability Accuracy [sec]	4
Indexing Accuracy [sec]	30
Weight [kg]	87
Servo Motor [FANUC]	αiF4 / 4000

Allowable load	Horizontal [kg]		160, 160
	Vertical [kg]		80, 80
Allowable cutting load	F [kN]		10
	F x L [N-m]		600
	F x L [N-m]		380
	Allowable Cutting Torque [N-m]		300

MS2-170LF4 4th axis type for Multi Spindle NC Rotary Table



Application / Benefits

Doubles production output, Ideal for balanced workpiece
Realize High Clamping Force by applying Double Piston

Model No.

MS2-170F4

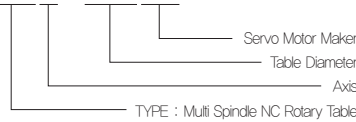

Servo Motor Maker

- | | |
|----------------|-----------------|
| F : FANUC | H : HEIDENHAIN |
| S : SIEMENS | L : LS MECAPION |
| M : MITSUBISHI | SY : SANYO |
| P : PANASONIC | FA : FAGOR |
| Y : YASKAWA | O : OKUMA |

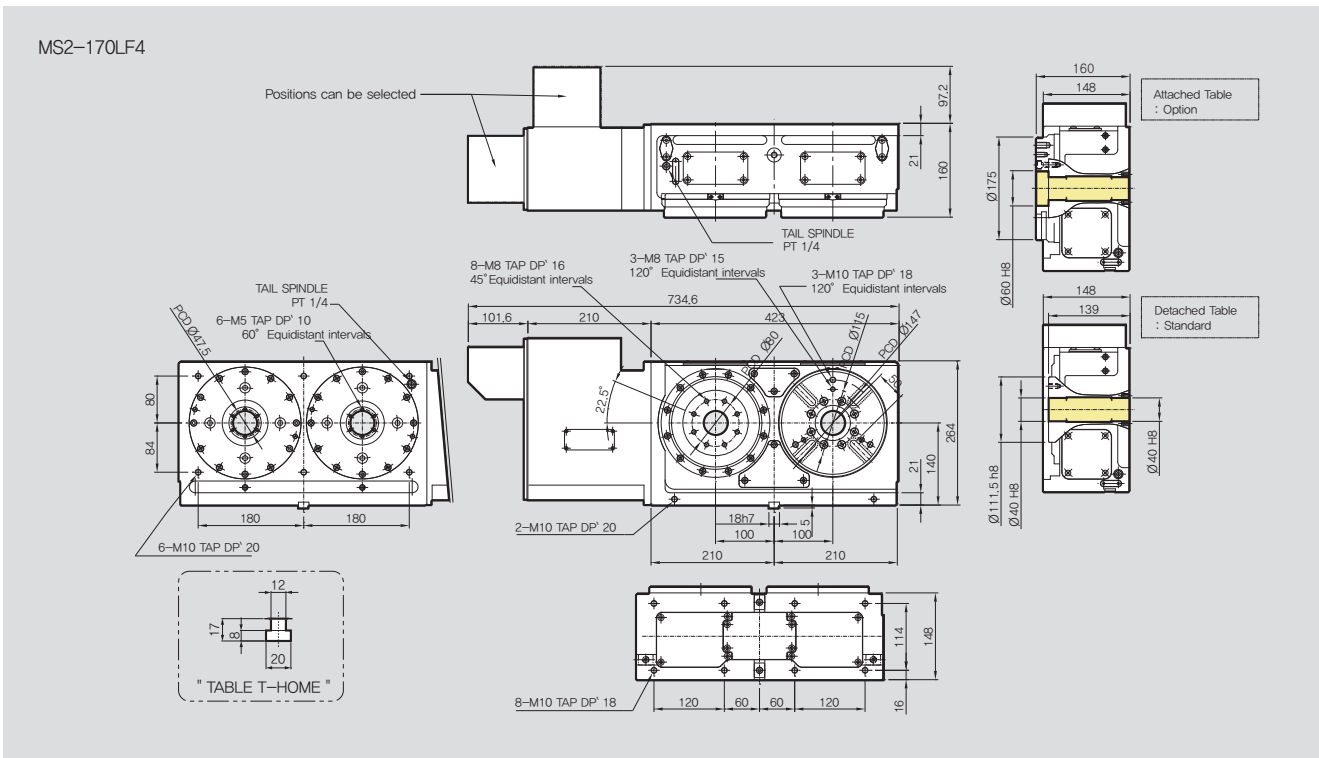

SPECIFICATIONS

Table Dia. [mm]	(Table: Option) Ø175
Center Height [mm]	140
Resister Dia. On Face Plate	Ø60H8
Spindle Through Hole Dia. [mm]	Ø40H8
Clamp Method	Pneumatic
Allowable Work Inertia [kgm ²]	0.51
Clamp Torque [N · m]	380
Max. Spindle Speed [mm ⁻¹]	44.4
Gear Ratio [mm]	1/90
Repeatability Accuracy [sec]	4
Indexing Accuracy [sec]	30
Weight [kg]	87
Servo Motor [FANUC]	αiF4 / 4000

Allowable load	Horizontal [kg]		160, 160
	Vertical [kg]		80, 80
Allowable cutting load	F [kN]		10
	F x L [N·m]		600
Allowable Cutting Torque [N·m]	F x L [N·m]		380
			300

MS2-170i, 170Li

Controller type for Multi Spindle NC Rotary Table



Application / Benefits

Doubles production output, Ideal for balanced workpiece
Realize High Clamping Force by applying Double Piston

Model No.

MS2-170Li

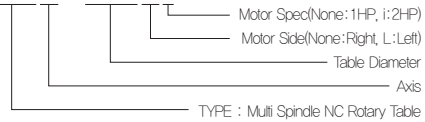

Servo Motor Maker

- | | |
|----------------|-----------------|
| F : FANUC | H : HEIDENHAIN |
| S : SIEMENS | L : LS MECAPION |
| M : MITSUBISHI | SY : SANYO |
| P : PANASONIC | FA : FAGOR |
| Y : YASKAWA | O : OKUMA |

MS2-170i

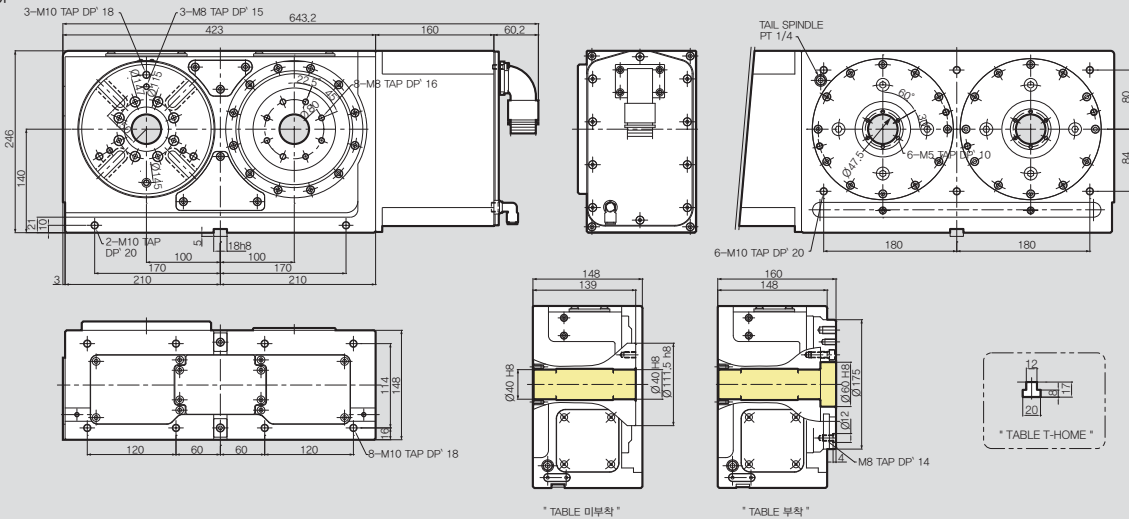

Net Weight(kg) : 87

MS2-170Li

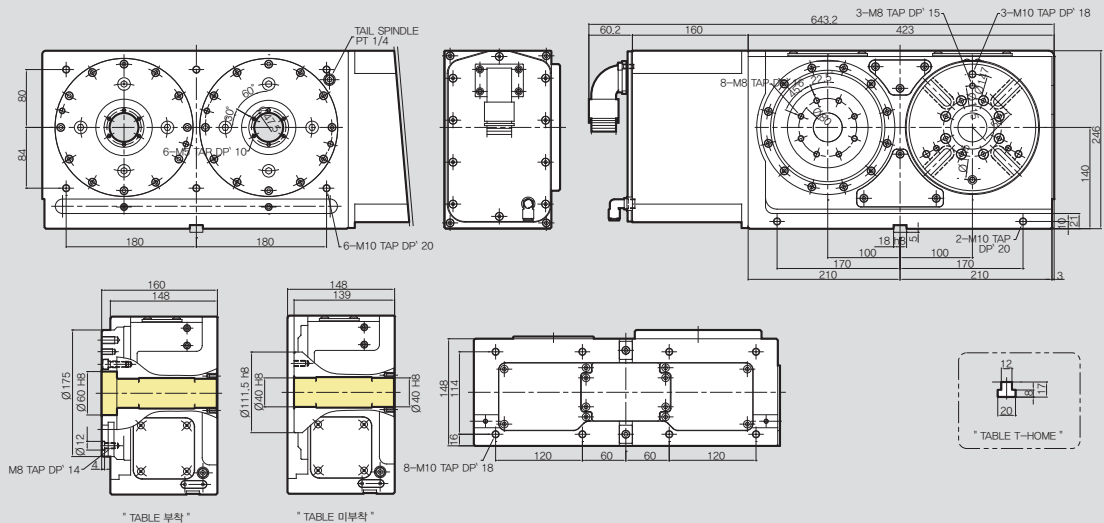

Net Weight(kg) : 87

※Product contents : The same with MS2-170F4(without servo motor)

DM-170 Direct Drive Motor NC Rotary Table



Application / Benefits

Max. table speed 200min⁻¹, Vertical & Horizontal available
 High Precision indexing system (With DD Motor), Compact Design
 Extremely Rigid Body, Yaskawa Direct Drive Motor

Model No.

DM-170

Table Diameter
 TYPE : Direct Drive Motor NC Rotary Table

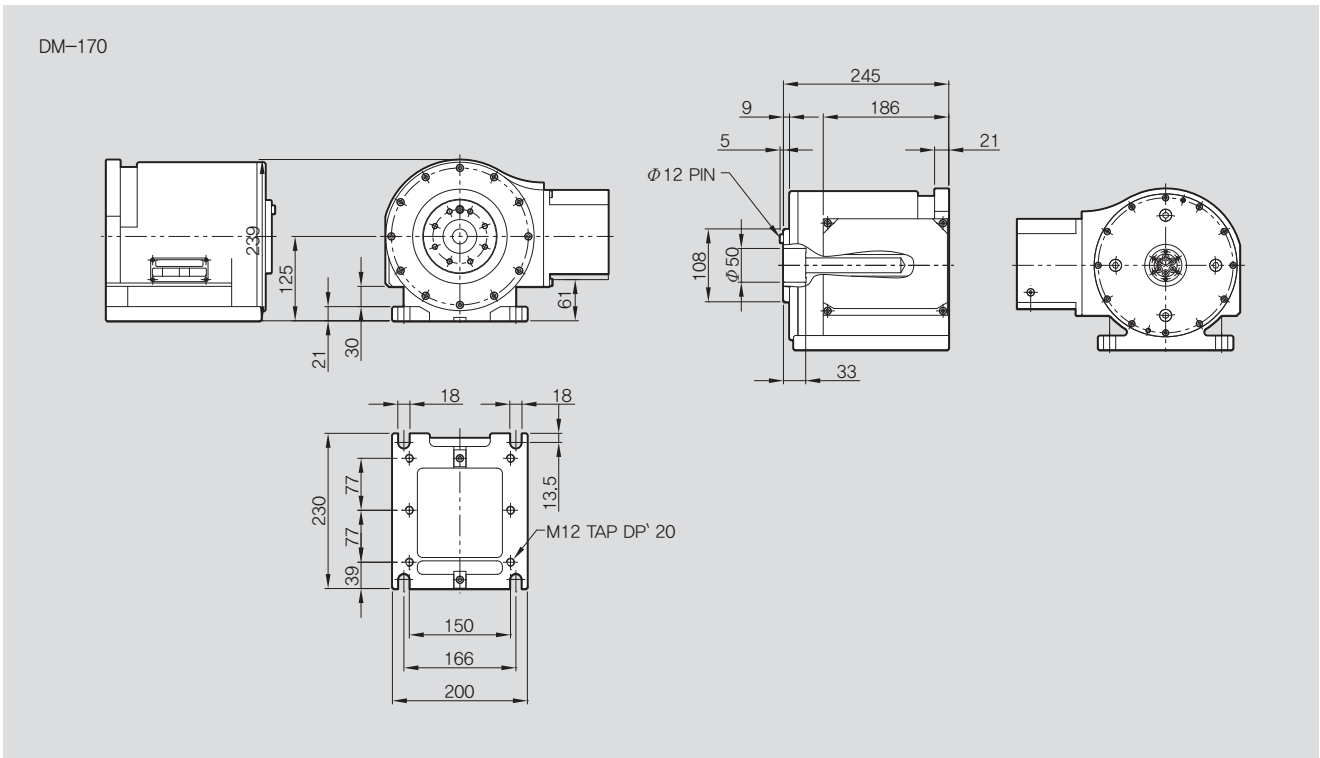

SPECIFICATIONS

Table Dia. [mm]	Ø170
Center Height [mm]	125
Resister Dia. On Face Plate	Ø50H7
Spindle Through Hole Dia. [mm]	-
Clamp Method	Pneumatic
Allowable Work Inertia [kgm ²]	-
Clamp Torque [N · m]	-
Max. Spindle Speed [mm ⁻¹]	200
Gear Ratio [mm]	1/1
Repeatability Accuracy [sec]	±1.3
Indexing Accuracy [sec]	15
Weight [kg]	64

Allowable load	Horizontal [kg]		-
	Vertical [kg]		-
Allowable cutting load	F [kN]		3300
	F x L [N·m]		-
Allowable Cutting Torque	F x L [N·m]		-
	[N·m]		-

DM-260 Direct Drive Motor NC Rotary Table

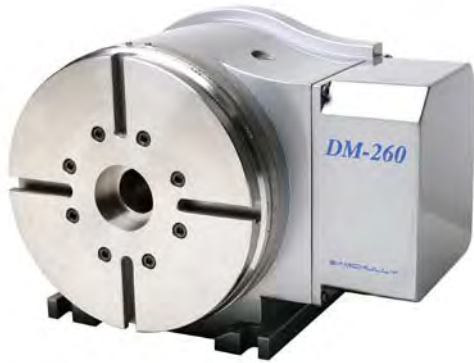

Application / Benefits

Max. table speed 200min⁻¹, Vertical & Horizontal available
 High Precision indexing system (With DD Motor), Compact Design
 Extremely Rigid Body, Yaskawa Direct Drive Motor

Model No.

DM-260





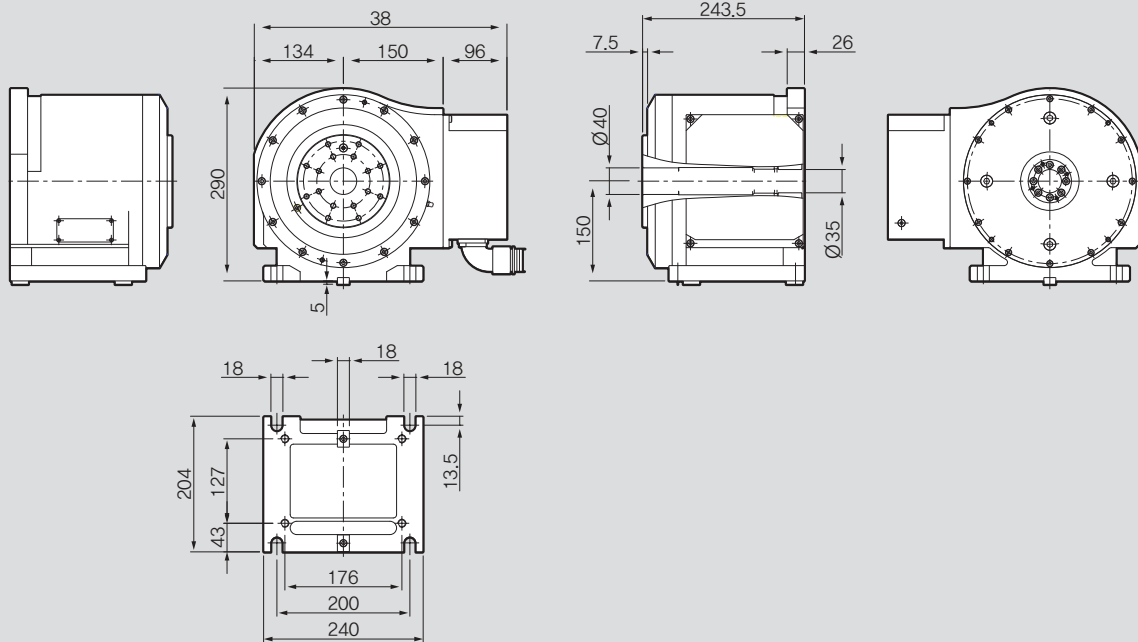

Table Diameter
 TYPE : Direct Drive Motor NC Rotary Table

DM-260



SPECIFICATIONS

Table Dia. [mm]	Ø258
Center Height [mm]	150
Resister Dia. On Face Plate	Ø60H7
Spindle Through Hole Dia. [mm]	Ø35H8
Clamp Method	Pneumatic
Allowable Work Inertia [kgm ²]	10 ⁻⁴
Clamp Torque [N · m]	400
Max. Spindle Speed [mm ⁻¹]	200
Gear Ratio [mm]	1/1
Repeatability Accuracy [sec]	±1.3
Indexing Accuracy [sec]	10
Weight [kg]	84

Allowable load	Horizontal [kg]		70
	Vertical [kg]		35
Allowable cutting load	F [kN]		4000
	F x L [N·m]		-
Allowable Cutting Torque [N·m]	F x L [N·m]		400
	Allowable Cutting Torque [N·m]		51

SR-200F4 Rear Mounted Motor 4th axis NC Rotary Table

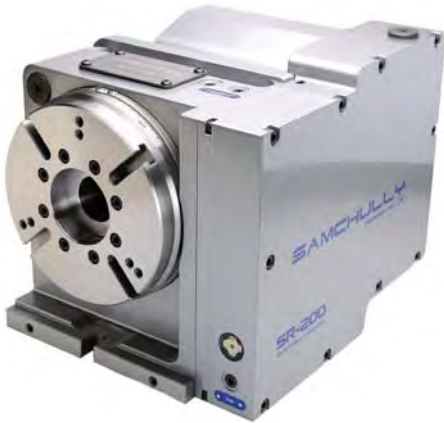

Application / Benefits

Maximize space with motor mounted on rear, Compact Design
Increased clamping force through double piston technology,
Extremely Rigid Body

Model No.

SR-200F4

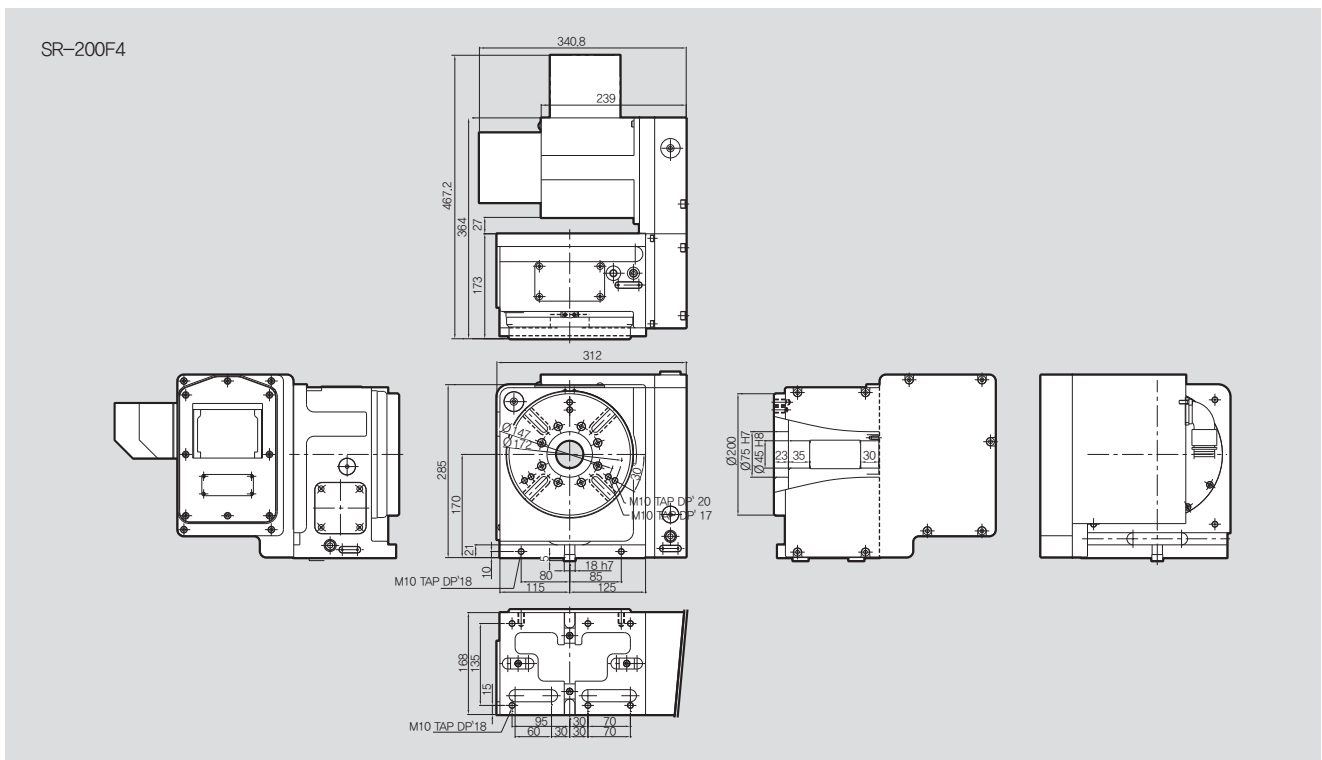

SPECIFICATIONS

Table Dia. [mm]	Ø200
Center Height [mm]	170
Resister Dia. On Face Plate	Ø75H7
Spindle Through Hole Dia. [mm]	Ø45H8
Clamp Method	Pneumatic
Allowable Work Inertia [kgm ²]	0.50
Clamp Torque [N · m]	500
Max. Spindle Speed [mm ⁻¹]	33.3
Gear Ratio [mm]	1/90
Repeatability Accuracy [sec]	4
Indexing Accuracy [sec]	40
Weight [kg]	78
Servo Motor	aiF4 / 4000

Allowable load	Horizontal [kg]		-
	Vertical [kg]		100
Allowable cutting load	F [kN]		17
	F x L [N-m]		1100
	F x L [N-m]		500
	Allowable Cutting Torque [N-m]		310

SR-200i Rear Mounted Motor Controller type NC Rotary Table

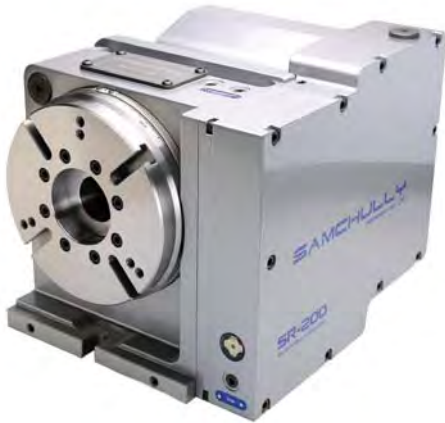

Application / Benefits

Maximize space with motor mounted on rear, Compact Design
Increased clamping force through double piston technology,
Extremely Rigid Body

Model No.

SR-200i

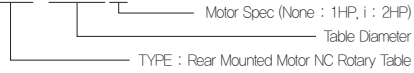

SR-200i

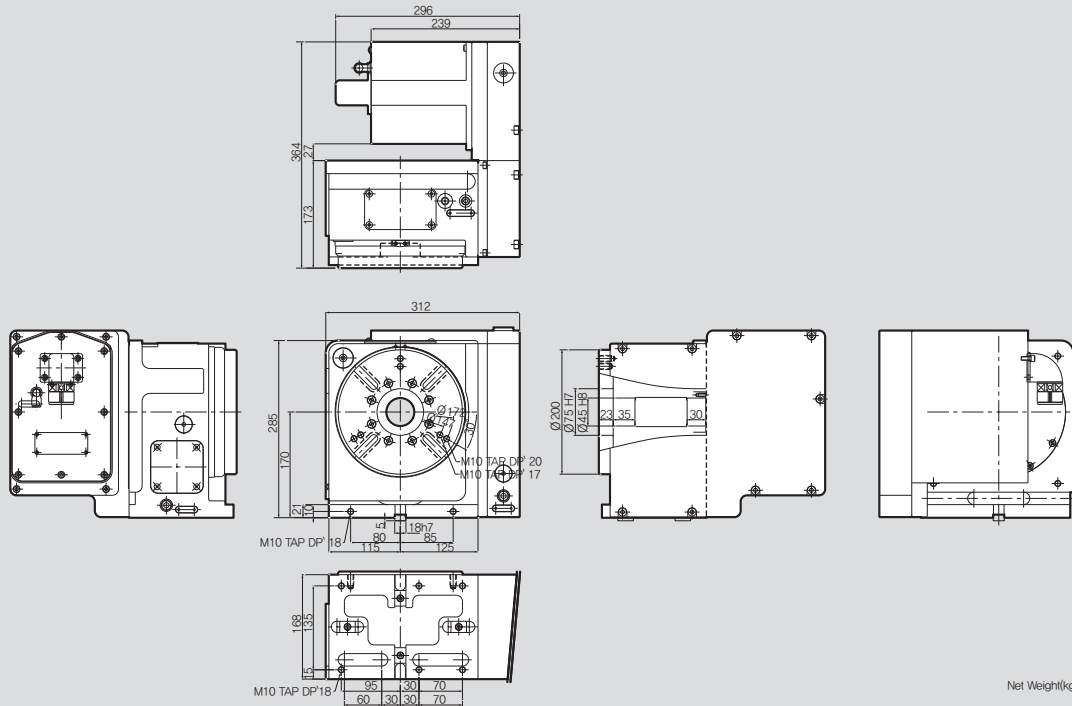

※Product contents : The same with SR-200F4(without servo motor)

MUT-600 Manual Turn Table



Application / Benefits

High Accuracy by Special Curvic Coupling
Easy to Heavy cutting and boring, Powerful clampingBody

Model No.

MUT-600

Table Diameter
TYPE : Rear Mounted Motor NC Rotary Table

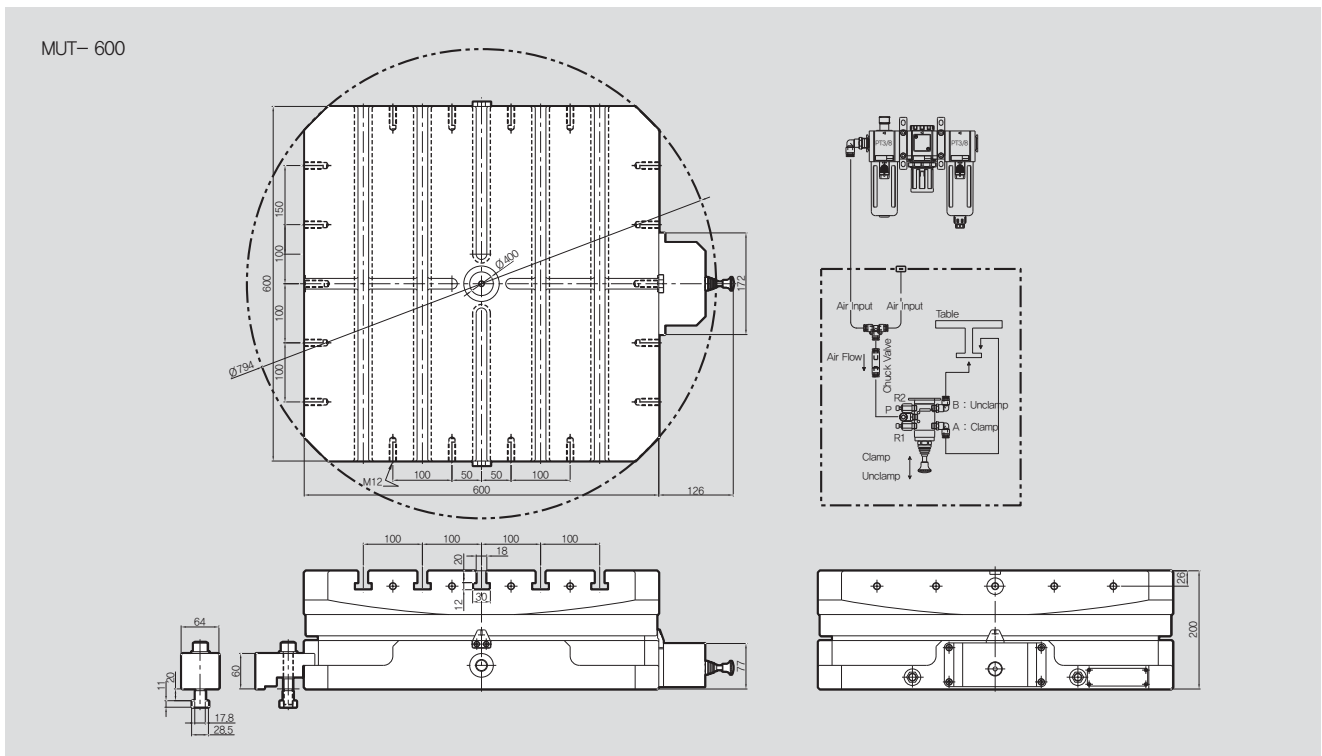

NC Rotary Table

SPECIFICATIONS

Table Dia. [mm]	600 x 600
Center-Hole Dia. [mm]	Ø40
Rounded Corners [mm]	Ø794
Height [mm]	200
Driving Method	Pneumatic 7kg/cm ²
Allowable Work Inertia [kgm ²]	90
Clamp Capacity [kgf]	3200
Width of T-slot [mm]	20H7
Indexing Accuracy [sec]	6
Min. Increment [deg.]	1° or 5°

Max. Thrust Load	Axial Force F		3500
	Radial Moment FxL		140
	Tilting Moment FxL		220
Max. Work Load	F x L [N-m]		2000
Weight	F x L [N-m]		400

12,17,20,25,32TS Tail Stock (Manual Type)



Application / Benefits

Center of Main Axis support, Usable Clamp Lever for Both side

Model No.

17 TS

TYPE : TS-Series / Tail Stock
Apply Model / S-170

12TS

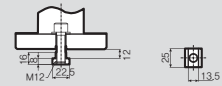
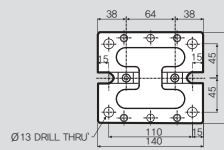
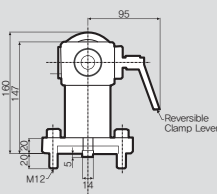
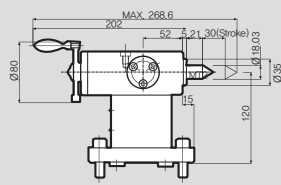

Net Weight(kg) : 9

17TS

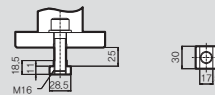
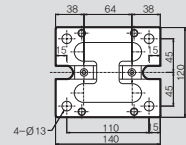
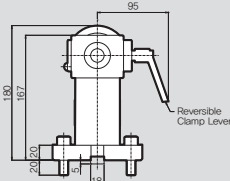
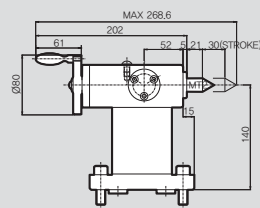

Net Weight(kg) : 10

20TS

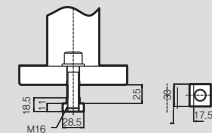
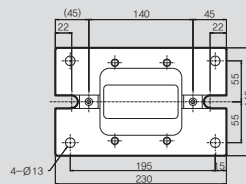
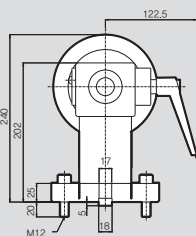
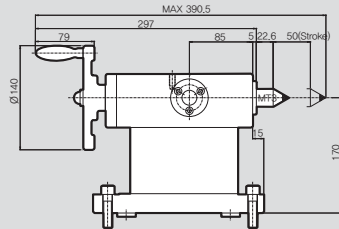

Net Weight(kg) : 19

25TS

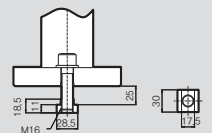
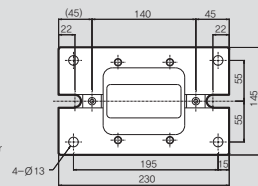
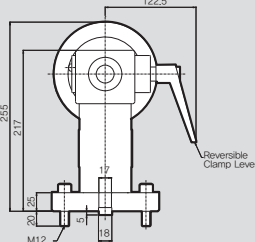
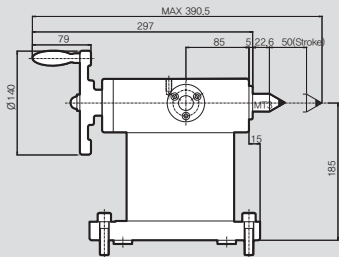

Net Weight(kg) : 20

32TS

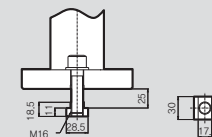
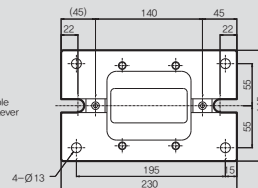
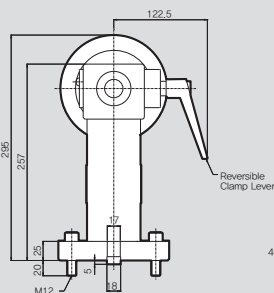
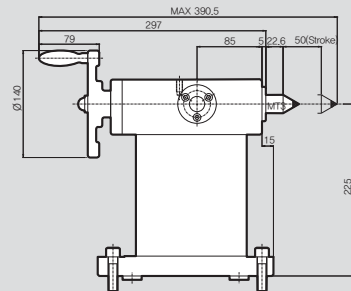

Net Weight(kg) : 21

43,51,65TS Tail Stock (Manual Type)



Application / Benefits

Center of Main Axis support, Usable Clamp Lever for Both side

Model No.

43 TS

TYPE : TS-Series / Tail Stock
Apply Model / S-430

43TS

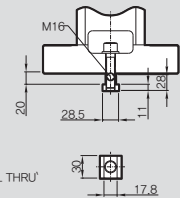
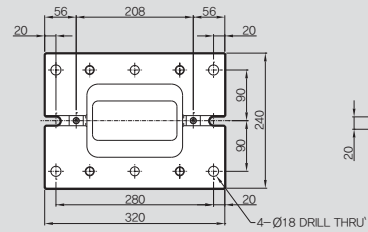
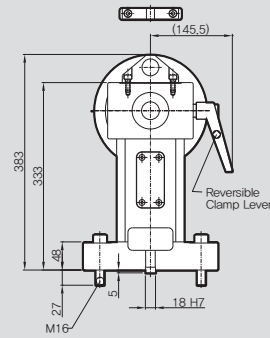
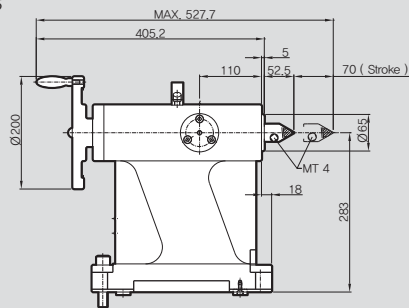

Net Weight(kg) : 70

51TS

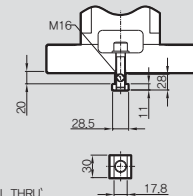
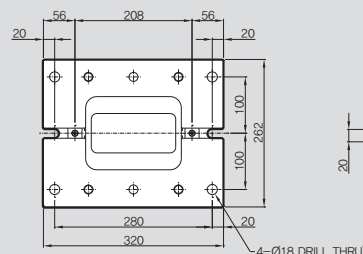
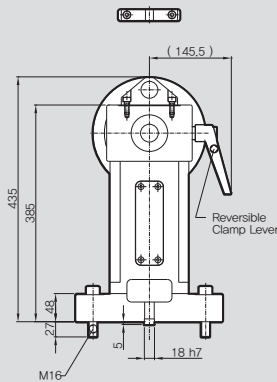
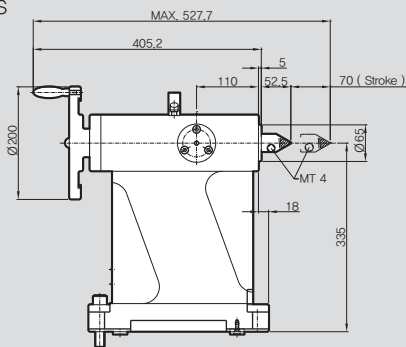

Net Weight(kg) : 95

65TS

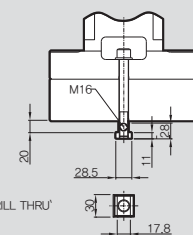
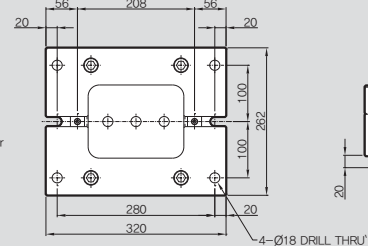
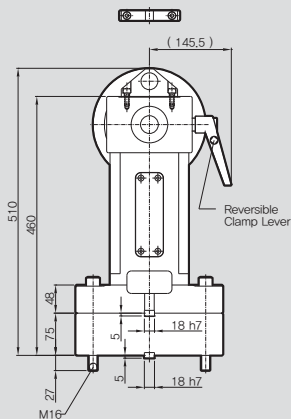
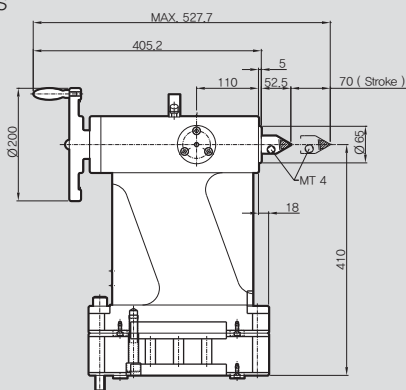

Net Weight(kg) : 135

17,20,25,32TS-AH Tail Stock (Air / Hydraulic Type)



Application / Benefits

For both Hydraulic and Pneumatic operation
Applicable to automation system, Hydraulic Clamp Max. 35bar

Model No.

17 TS-AH

Clamp : Air / Hydraulic
TYPE : TS-Series / Tail Stock
Apply Model / S-170

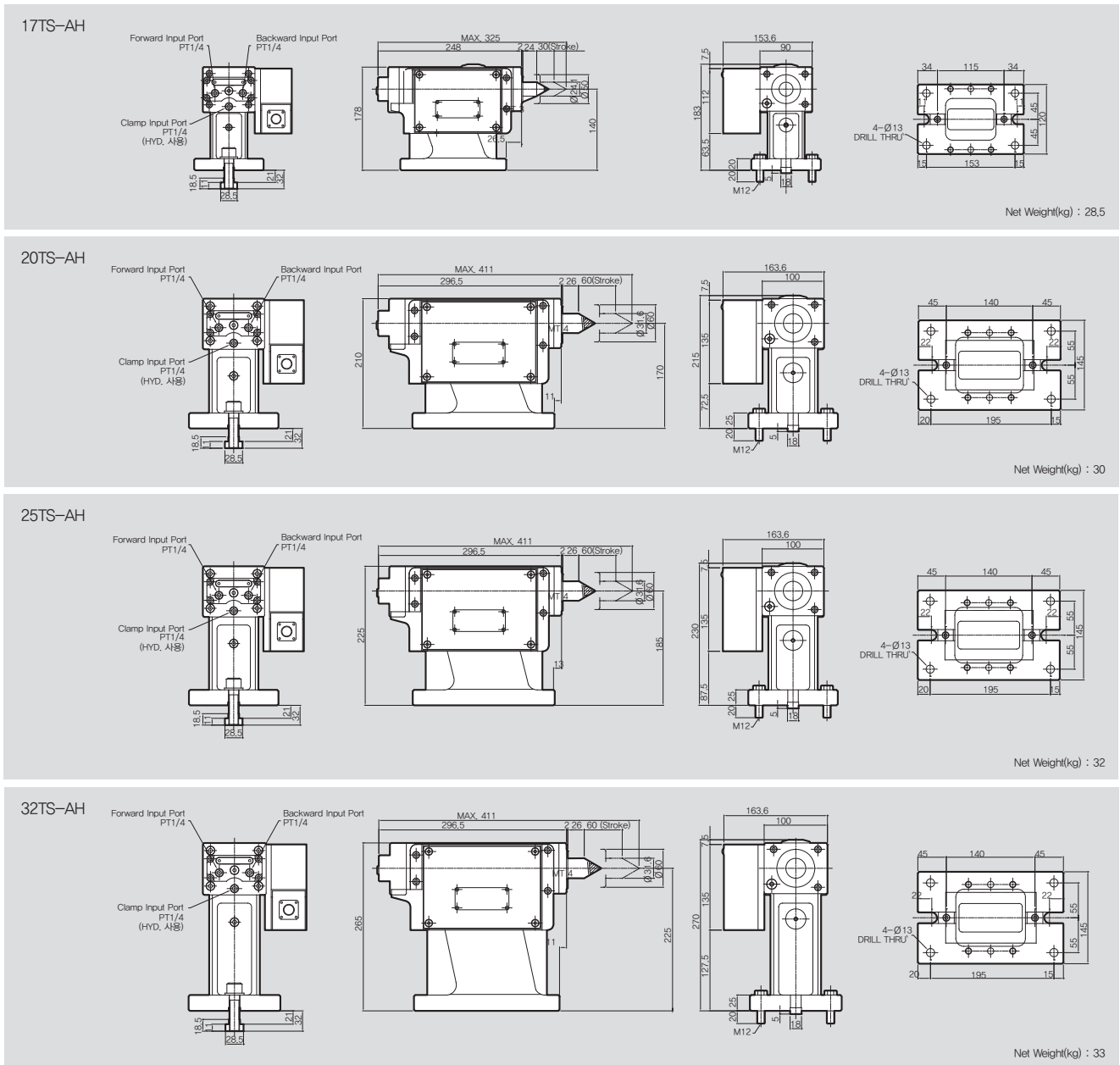

NC Rotary Table

17,20,25,32SP-A Tail Spindle (Air Clamp Type)



Application / Benefits

Rotation of Work & Jig with Weight Support, Air Clamp type

Model No.

17 SP-A

Clamp / Air
TYPE : SP-A Series / Tail Spindle
Apply Model / S-170

17SP-A

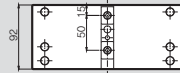
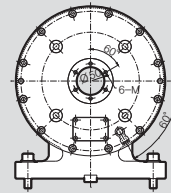
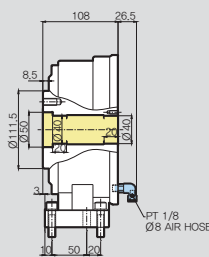
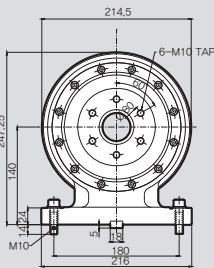

Net Weight(kg) : 26

20SP-A

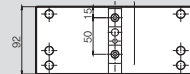
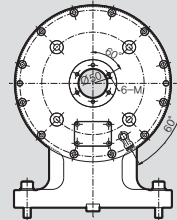
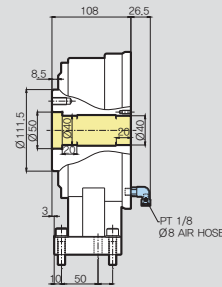
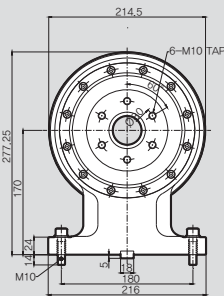

Net Weight(kg) : 33

25SP-A

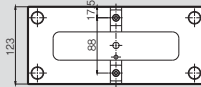
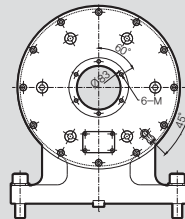
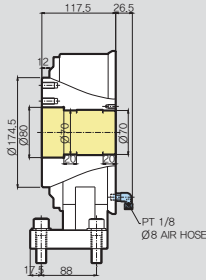
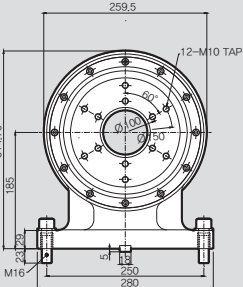

Net Weight(kg) : 60

32SP-A

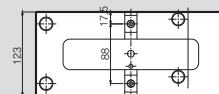
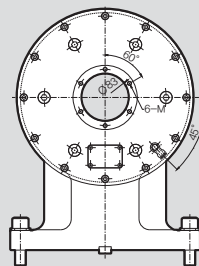
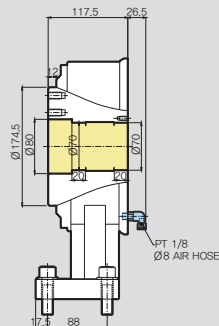
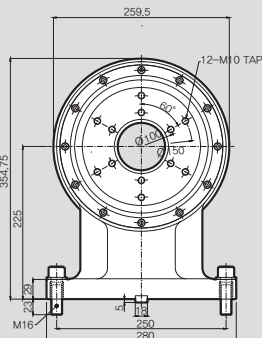

Net Weight(kg) : 64

20,25,32SP-H Tail Spindle (Hydraulic Clamp Type)

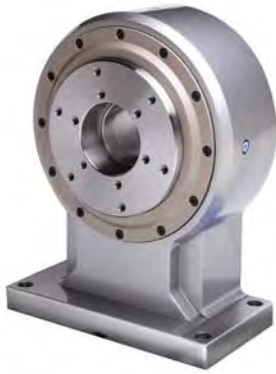

Application / Benefits

Rotation of Work & Jig with Weight Support, Hydraulic Clamp type

Model No.

17 SP-H

Hydraulic Type
 TYPE : SP-H Series / Tail Spindle
 Apply Model / HRS-174

17SP-H

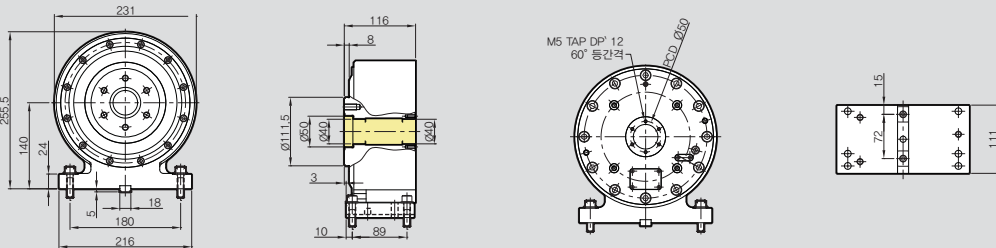

Net Weight(kg) : 28

20SP-H

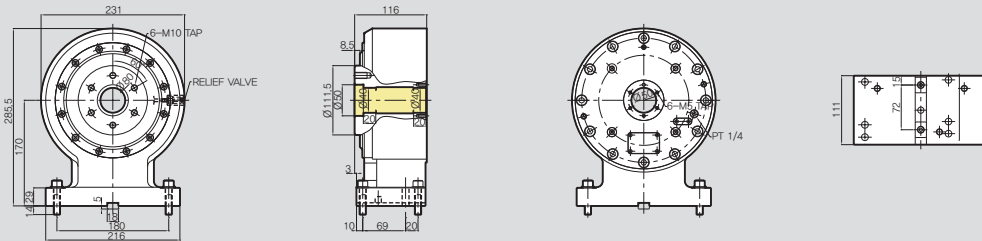

Net Weight(kg) : 35

25SP-H

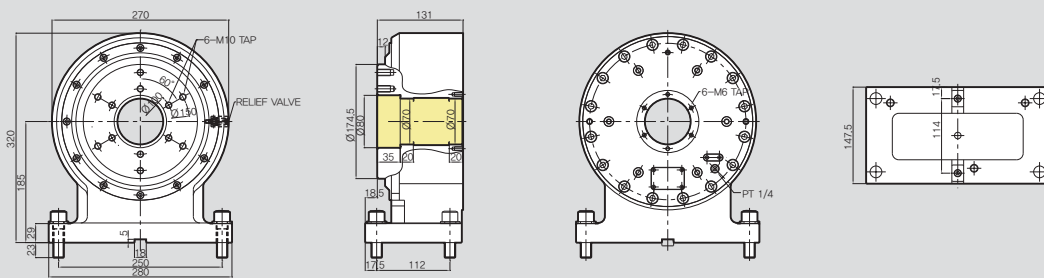

Net Weight(kg) : 62

32SP-H

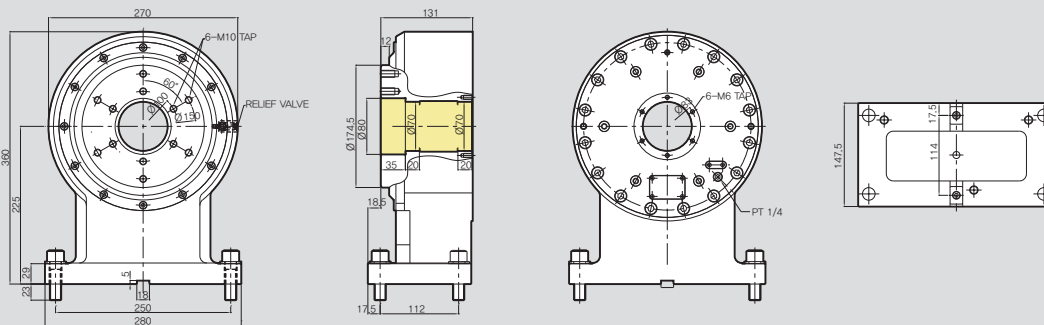

Net Weight(kg) : 66

NC Rotary Table

50AH-C Air Booster (Single)



Application / Benefits

Effects of hydraulic clamp force using pneumatic S series Large Type, HRS series applicable

Model No.

50 AH-C

Operation Type / Single
TYPE : AH -C series / Air Booster
Pressure

50AH-C

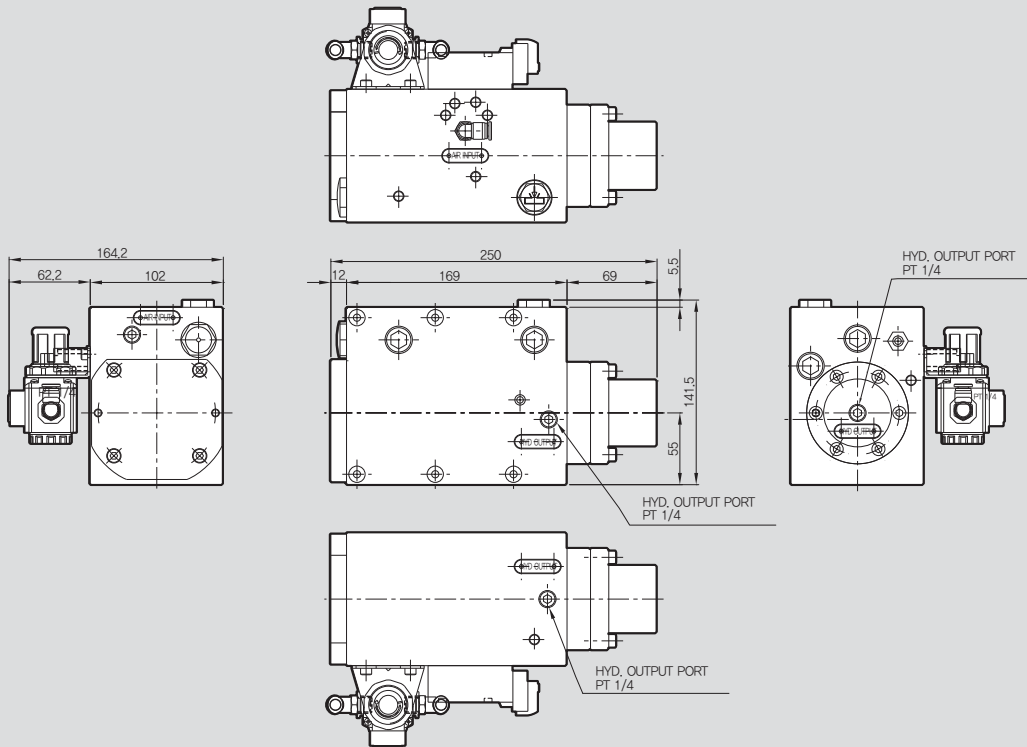

SPECIFICATIONS

Input Air Pressure	0.4 ~ 0.45
Output Hydraulic Pressure	3.2 ~ 3.6
Solenoid Voltage	DC 24V
Multiplication Ratio	1 : 8

Recommended Oil	Turbine Oil #32
Discharge Rate	50cc
Weight	7

50AH-T Air Booster (Twin)



Application / Benefits

Effects of hydraulic clamp force using pneumatic TR, MTR series Large Type, HRS series applicable

Model No.

50 AH-T



50AH-T

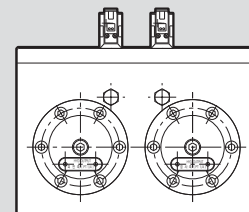
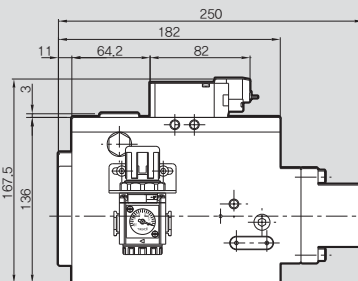
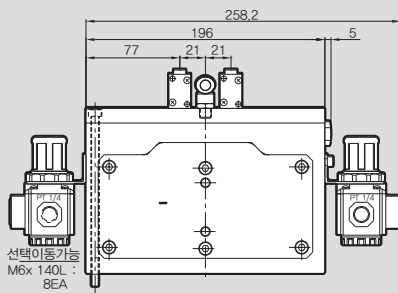
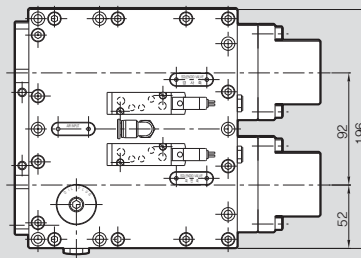

SPECIFICATIONS

Input Air Pressure	0.4 ~ 0.45
Output Hydraulic Pressure	3.2 ~ 3.6
Solenoid Voltage	DC 24V
Multiplication Ratio	1 : 8

Recommended Oil	Turbine Oil #32
Discharge Rate	50cc
Weight	12.5



NeoCon Samchully Controller



Application / Benefits

NeoCon Series : 1 axis, minimal denominational setting: 0.001°
100ch 100,000 Block

Convenient Setting

AUTO MODE(automatic run)

Runs program entered in EDIT mode. Each time the smart signal is entered, one block is run
External M code also runs at this time

EDIT(edit program)

The mode in which the program to be auto run is entered
The data is processed via a PC software
(software is required)

PARAMETER

The mode in which internal parameters are set

SINGLE

Runs similarly to Auto mode but when 1 BLKFIN is output, G99Fin does not output

MANUAL

Manual operation – home position, machining zero position
Hand pulse generator is also operated in this mode

Convenient Operation

- Key arrangement is conveniently similar to a CNC machine
- A variety of parameters offered for the everyday user
- various modes and editorial functions

Interface

- may be used as an standalone unit
- suitable for dedicated machines
- compatible with tapping and machining centers

Various Features

- 4.8" full color TFT LCD screen
- sleep mode
- programmable via USB and MPG
- maximum of programmable 100,000 blocks
- 100 channels with 1000 blocks per channel

NeoCon Samchully Controller



NeoCon Samchully Controller

Specifications and Functions

Specifications	Descriptions
Controlled axes	1 axis
Program Capacity	Back up the External SD card (Parameter, Work Program)
Servo Motor Specification	AC servo motor with absolute encoder
Setting Unit	0,001°
Max. setting angle	999 Rotation + 360° (±999,999°)
Programmable capacity	100,000 Block (100 channels, Each Channel 1,000 Block)
Command Method	ABSOLUTE /INCREMENTAL methods (Choice between G90/G91)
Zero position return	Zero and zero point return
Manual Feed	Rapid traverse, slow speed feed and step feed, STEP traverse, MPG traverse
Emergency Stop	Emergency stop button or forced servo stop by external interlock input and master stop
Halt	Halt of rotary table by key input or external SP input
Feedrate override	Settable 1 to 100% (can be notched 1 to 100%)
Preparatory function	DWELL, LEAD CUTTING, BUFFER FUNCTION, CLAMP PRESENCE, DEVIATION CHECK FUNCTION, INTERLOCK START, CONTINUOUS START, MZRN, WZRN, REPEATING FUNCTION, LOOP JUMP FUNCTION, ABSOLUTE/INCREMENTAL, FIN SIGNAL CONTROL COMMAND
Jump to subprogram	Jump to subprogram
Software limit function	Software can be set from machine zero position to prevent interference with the machine by mounting jigs or workpiece
Over travel stop function	Hard limit mode can control the rotary range of rotary table
Pitch error compensation	Pitch error can be compensated per 15° (min. set unit: 0,001°)
Backlash	Backlash compensation is adjustable
Alarm function	When error is detected, alarm number and alarm message are automatically displayed
Self-Diagnosis Function	Machine coordinate, work coordinate (command value, encoder value), remained movement, I/O signal state, position deviation, current %, encoder electric angle
Input Power	Single Phase AC200/230V ±10% 50/60Hz, 3 Phase AC220/230V ±10% 50/60Hz
Apparent Power	1.0 KVA
Net Weight	7.5 kg
Environment	Controller Temperature: 0–45°C Storage Temperature: –10°C~60°C C Humidity: below 85% RH Internal Vibration: 0.5 Internal Impact: Below 1G
Display	4.8 " TFT LCD
Optional Port	RS232C cable, MPG Handle, USB AM Cable (external equipment can I/O program, parameters, etc.)
External Input Signal	START, STOP, external EMG STOP, external channel selection
External Output Signal	Block completed, 360° comp., optional completed signal, MZRN completed, EMG STOP output signal, alarm output signal

G Code Function

G Code	Function	Description
None	Rotation	Only calculation command is available.
G04	speed command	No movement, wait for time.
G07	Dwell	Rotate the table by multiple turns.
G08	Lead cut	Executes program block continuously, until the following G09 command.
G09	Continuous buffer	Cancel the continuous beffer of G08, return to the ordinary single block run.
G10	Continuous buffer cancel	Set the clamp device at table stop to unused, which is effective until the next G11 command.
G11	Clamp unused	Cancel the clamp device of G10 unused state, and apply clamp at table stop.
G15	Emphasizes the interlink	Emphasis the interlink by checking the deviation in the positions of the program blocks when the continuous buffer is effective (G08). The checking of deviation in position is effective until the next G16 command.
G16	Position check deviation invalid	Cancel the effectiveness of the position deviation check function. Do not check the deviation in the positions of the programs.
G21	Interlink start	This function outputs block finish signal prior to motion in program running, which is used for the interlinked operation with the machine, etc.
G22	Continuos start	If G22 is commanded, the table rotates continuously until the next start input.
G23	Machine start point return	Position at the machine origin point of the table.
G24	Process start point return	Position at the origin of the process coordinate system of the table.
G25	Escape loop	Run the program inloop until the process start point is reached. When reached, escape from the loop and execute the next block.
G27	Repetition	Repeat execution of the program by specified number of times, from the designated block to the block.
G90	Absolute	Execute positioning in the absolute coordinates of the process coordinate system.
G91	Incremental	Execute positioning in the relative coordinates.
G92	Process coordinate system setting	Process start point can be set up as desired in the program.
G97	No block finished	Do not output the block finish (BLKFIN).
G98	Block arbitrary finish output	In the program execution, too, provide block finish (BLKFIN) and arbitrary finish (G99 FIN) output.
G99	Arbitrary finish output	Output the arbitrary finish (G99FIN) only, not block finish .

Address Function

Address	Description	Setting Unit	Setting Range	Remark
G		*Refer to the G Code function section.		
A	Rotation angle command	Degree	± 999.999	
	Dwel time command	Sec	0.01~999.99	
F	Rotation speed command	0.01min ⁻¹	0~5000	1/60 (differ as Gear Ratio)
J	Jump command	Block No.	0~99	Jump prior to the command block
	Subroutine command	Block No.	0~99	Jump prior to the command block
	Return command	Return No.	-1	End of 1 turn subroutine
D	Partition command	No.of partitions	0~999	
S	Beginning block NO. command of repetition function (G27)	Block No.	1~999	
E	End block NO. command of repetition function (G27)	Block No.	1~999	
R	Frequency of repetition function (G27) command	No. of repetitions	1~99	
	G99 command of interlinked start function(G21)	G99 command No.	99	G99 command is executed in the same block as the G21 command.

Program

항목	내용	구동방법	화면
Angle Index	90° rotation 45° rotation and N000 movement		<p>① N000 G91 <u>A90</u> <u>F1000</u> Angle Rotation speed</p> <p>② N001 G91 <u>A45</u> <u>F1000</u> <u>J00</u> Jump function</p>
Equipartition	360° angle with 8 partitions and N000 movement		<p>N000 G91 <u>A360</u> <u>F1000</u> <u>D8</u> <u>J00</u> Angle Partition</p>
Unequal Partition	90° rotation 30° rotation 120° rotation 45° rotation 75° rotation, change to rpm 2000 and N000		<p>① N000 G91 <u>A90</u> <u>F1500</u> ② N001 G91 <u>A30</u> <u>F1500</u> ③ N002 G91 <u>A120</u> <u>F2000</u> ④ N003 G91 <u>A45</u> <u>F2000</u> ⑤ N004 G91 <u>A75</u> <u>F2000</u> <u>J00</u> Rotation speed</p>
Repetition	N004 ~ N006 2 cycles 40° rotation, 30° rotation, 50° rotation (1 time/cycle) 40° rotation, 30° rotation, 50° rotation (2 times/cycles)		<p>N000 <u>G27</u> <u>S4</u> <u>E6</u> <u>R2</u> Repetition Start End Cycle command</p> <p>① ④ N004 G91 <u>A40</u> <u>F2000</u> ② ⑤ N005 G91 <u>A30</u> <u>F2000</u> ③ ⑥ N006 G91 <u>A50</u> <u>F2000</u></p>
Absolute / Incremental	90° rotation from absolute coordinates 225° rotation from absolute coordinates 90° rotation from opposite coordinate		<p>① N000 <u>G90</u> <u>A90</u> <u>F1000</u> Absolute Angle</p> <p>② N001 <u>G90</u> <u>A225</u> <u>F1000</u></p> <p>③ N002 <u>G91</u> <u>A90</u> <u>F1000</u> Incremental Angle</p>
Subprogram	90° rotation, N010 movement 30° rotation from opposite coordinate 40° rotation and return N001 movement 270° rotation from absolute coordinate and N010 movement 30° rotation from opposite coordinate 40° rotation and return (N002 movement) 20° rotation and N000 movement		<p>① N000 <u>A90</u> <u>F1000</u> <u>J10</u> Angle Jump</p> <p>④ N001 <u>G90</u> <u>A270</u> <u>J10</u> Absolute Jump</p> <p>⑦ N002 <u>A20</u> <u>J00</u> Angle</p> <p>② ⑤ N010 G91 <u>A30</u> ③ ⑥ N011 <u>A40</u> <u>J-1</u> Return Function</p>

Application

Hydraulic Chuck & Hydraulic (Pneumatic) Cylinder



Application / Benefits

Maximize space with motor mounted on rear, Compact Design
 Increased clamping force through double piston technology,
 Extremely Rigid Body

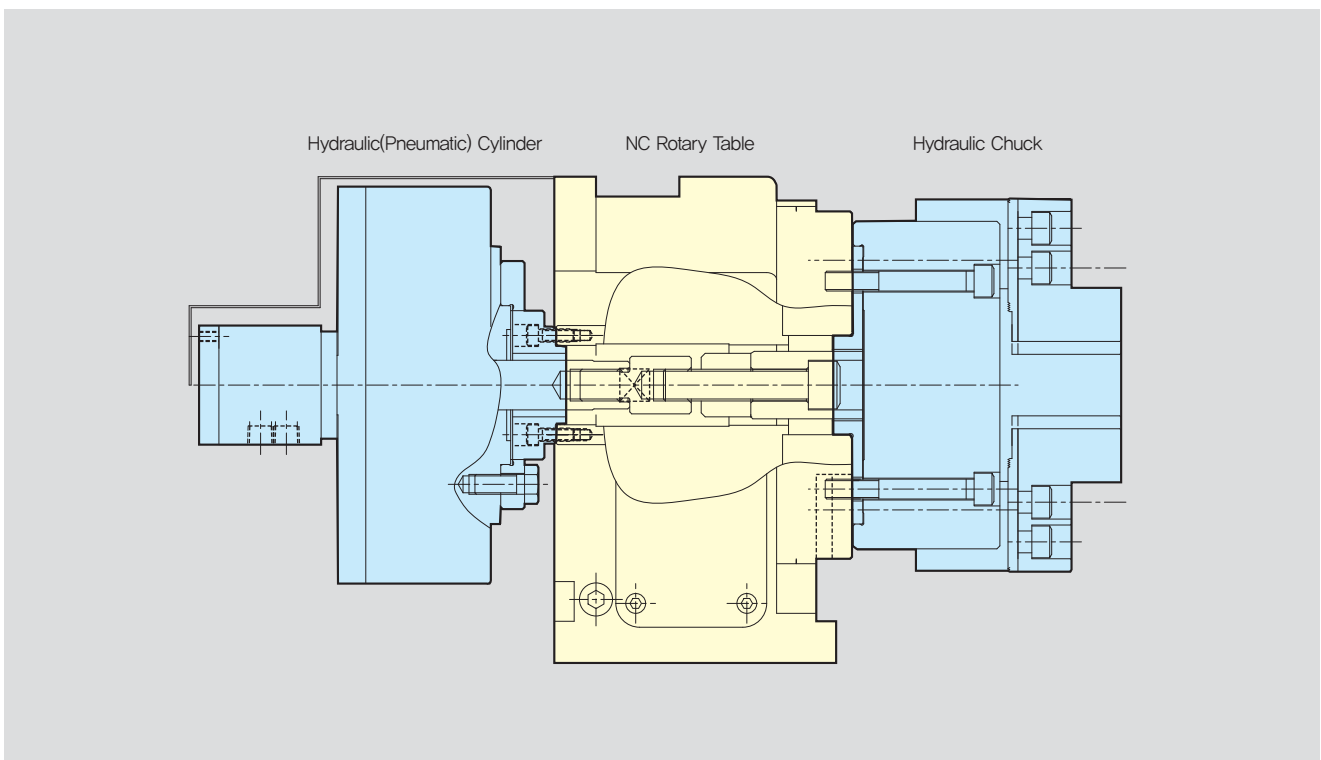

NC Rotary Table

	S-170		S-200		S-250		S-320	
Hydraulic Chuck	HC-05	HC-05	HC-05	HC-05	HC-05	HC-05	HC-05	HC-05
Grip Dia	16~135	16~135	16~135	16~135	16~135	16~135	16~135	16~135
Hydraulic Cylinder	Y-0715(R)RE	Y-1020(R)RE	Y-1020(R)RE	Y-1225(R)RE	Y-1225(R)RE	Y-1225(R)RE	Y-1225(R)RE	Y-1530(R)RE
Air Cylinder	AY-1315R	AY-1720R	AY-1720R	AY-2225R	AY-2225R	AY-2225R	AY-2225R	AY-2730R

Application Technical Information

NC Rotary Table

Works with the CNC Controller to allow operation in multiple axes. A rigid clamping brake allows for high cutting force with high precision required for piece work or mass production.

A. Controller type (NeoCon-TYPE)

- Rotational accuracy ensures precise segment and angular accuracy with minimal backlash
- External signal (M Code) controls operation.
- Simple attachment, fast installation, minimal cost.
- Available with G code option.

B. Multi Axes type (4th Axis-type)

- Thread cutting, contour cutting, CAM, helical operation
- Power and precision with multi axes machining.
- Operates with both rotary table controls and the CNC controller.

Gear Ratio

$$\text{Rotary Table Spindle Speed} = \frac{\text{Motor Spindle Rotation speed}}{\text{Gear Ratio}}$$

$$\text{NT-170 Spindle Speed} = \frac{3000}{72} = 41.6 \text{ RPM}$$

The calculation of the RPM : This is done by calculating the rotation of the motor and the table.

DUAL – LEAD WORM GEAR

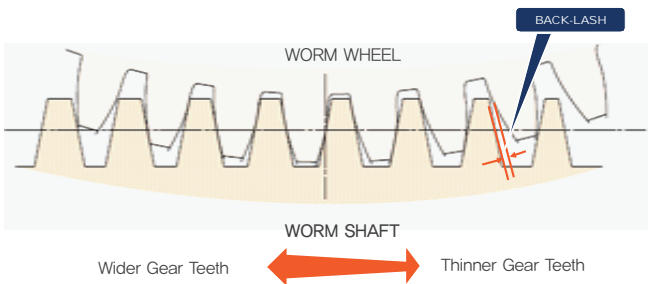

The adjustable worm gear allows the operator to remove backlash as the worm wheel and worm shaft wear.

Cutting torque limit (N.m)

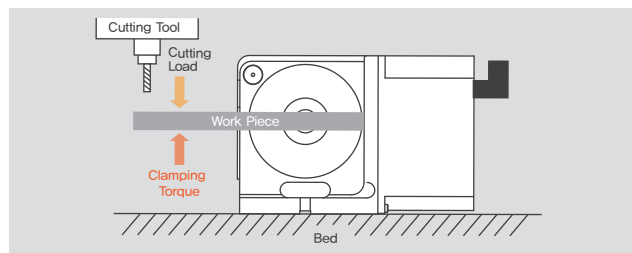

Failure to limit the cutting torque can damage the worm wheel and worm shaft.

Indexing Accuracy

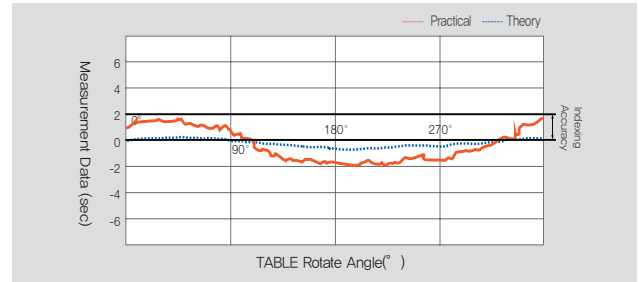

The variance between the worm wheel and worm shaft when rotated a full 360°

Repeatability Accuracy

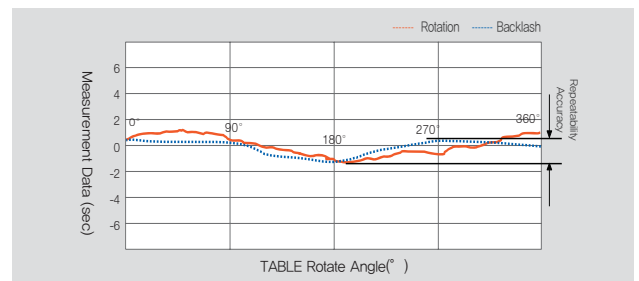

Accuracy variance when operated in both directions.

BACK-LASH

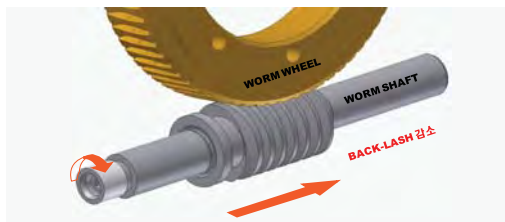

Endurable power of worm gear from cutting load. cutting load > permitted cutting torque could get error due to gear or motor of overload

Clamp Torque (N.m)

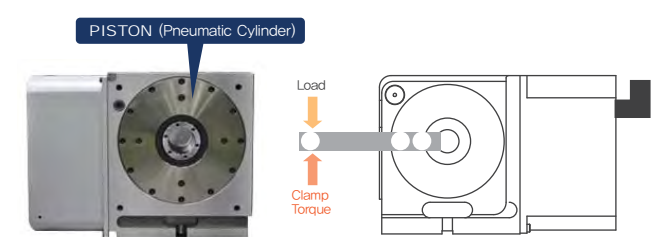

Clamping the brake disc with air pressure

Application NC Rotary Table installation

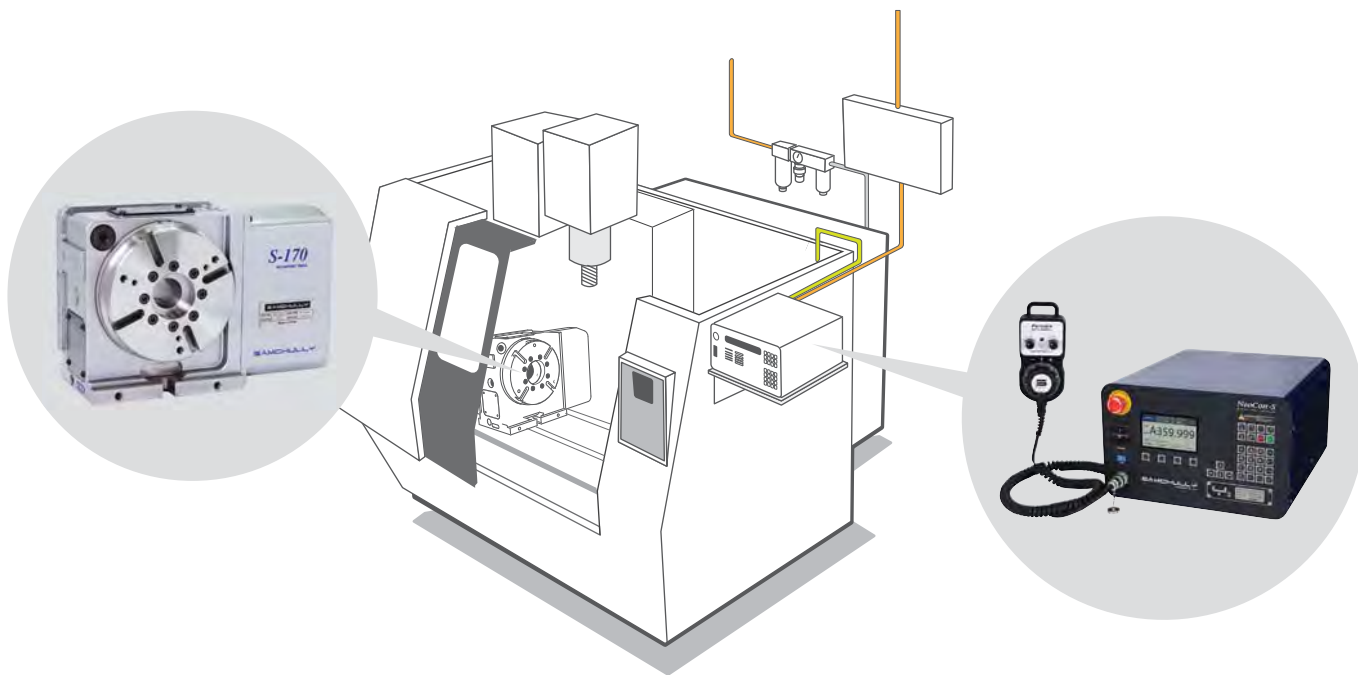

Air Supply Installaton

Air clamp system is located inside of the NC Rotary Table. Air filter regulation is needed to use the clamp functions. This is an option to the standard supply.

Parts Required:

Air filter & regulator

Air hose

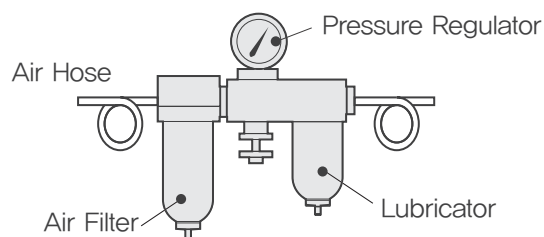

Controller Type

The Samchully NeoCon controller is ideal for simple machining that requires basic indexing application. The controller is simple to install and economical.

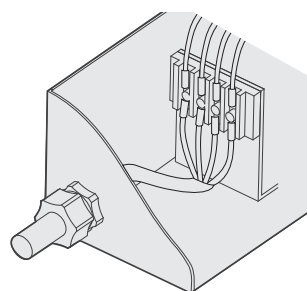

4th Axis Type

The 4th axes option allows for contour / helical cutting. The rotary table connects directly with the controller for optimal manufacturing flexibility. The Samchully rotary table is compatible with Fanuc, Siemens, Mitsubishi, Panasonic, Yaskawa, Heidenhain, LS mecapian, Sanyo, Fagor, and Okma controllers.

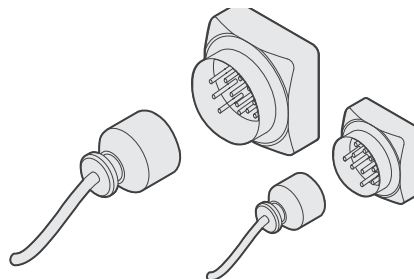



WISE

Samchully vises are integral solutions for various applications. Our power vises are featured with a torque setter to ensure high repeatability and durability.

Whether used on a machine table, jig or even on a custom machine, our vise line is an added value to your production.



SPV

Serration type
Power Vise

222 P



FV

Flexible Vise

234 P



CMV-R

Self centering
5-Axis Vise

223 P



VS

Standard
Machine Vise

236 P



CMV-S

Self centering
5-Axis Vise

224 P



MMV

Mechanical
Machine Quick Vise

238 P

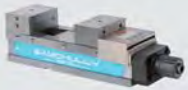

PCV

Standard
Power Vise

226 P



APV

Air Vise

240 P



PSV

Short Type
Power Vise

228 P



PLV

Long Stroke Type
Power Vise

230 P



DDV

Draw Down Type
Power Vise

232 P



MDV

Double Power Vise

233 P

SPV Serration type Power Vise

Jaw Width Range : 160mm
Max. Opening Range : 300mm



Application / Benefits

Serration type for easy Jaw setting(Pitch=3.0mm)

Technical features

Minimal jaw set-up times

Sealed cover prevents swarf contamination

SPECIFICATIONS

	SPV-156
Jaw Width [mm]	160
Jaw Height [mm]	115
Max. Opening [mm]	300
Total Height [mm]	175
Slider Height [mm]	115
Total Width [mm]	161
Total Length [mm]	595.5
Max.Gripping Force [kN(kgf)]	60(6100)
Weight [kg]	73

※ Specifications are subject to change without notice.

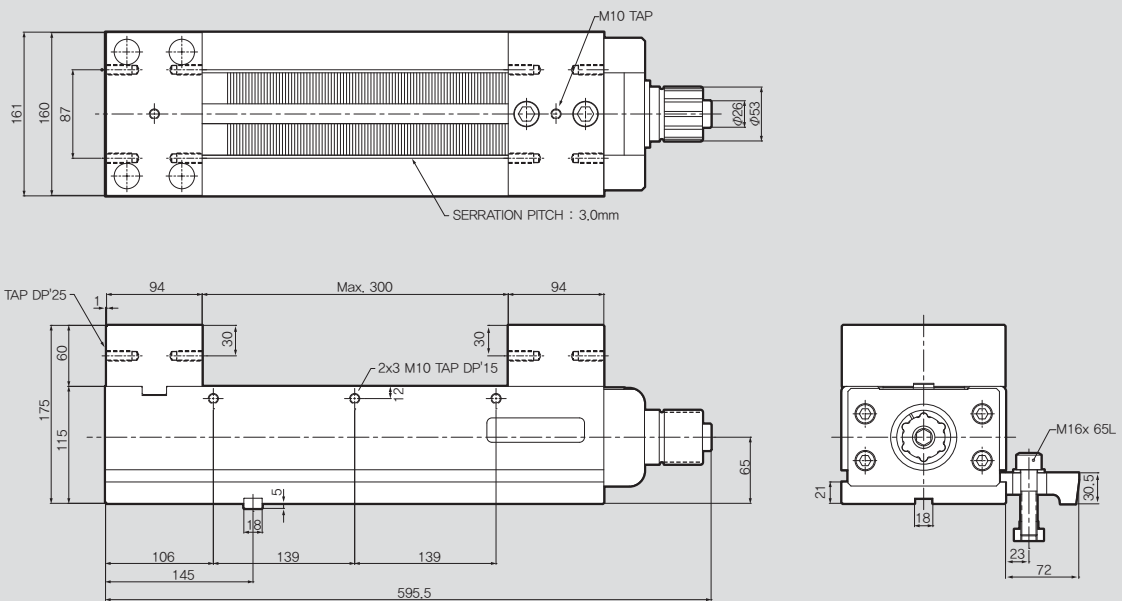

CMV-R 5-Axis Centering Vise

Jaw Width Range : 125mm
Max. Opening Range : 125mm



Application / Benefits

Self centering 5-Axis vise

Technical features

Repeats within 0.02mm or lower. Uses 1.5 pitch serration jaws
Able to use a variety of jaws for various workpieces

SPECIFICATIONS

	CMV-125R
Jaw Width [mm]	125
Jaw Height [mm]	20
Max. Opening [mm]	125
Total Height [mm]	125
Slider Height [mm]	80
Total Width [mm]	125
Total Length [mm]	Ø 200
Max. Gripping Force [kN(kgf)]	20(2000)
Weight [kg]	17

※ Specifications are subject to change without notice.

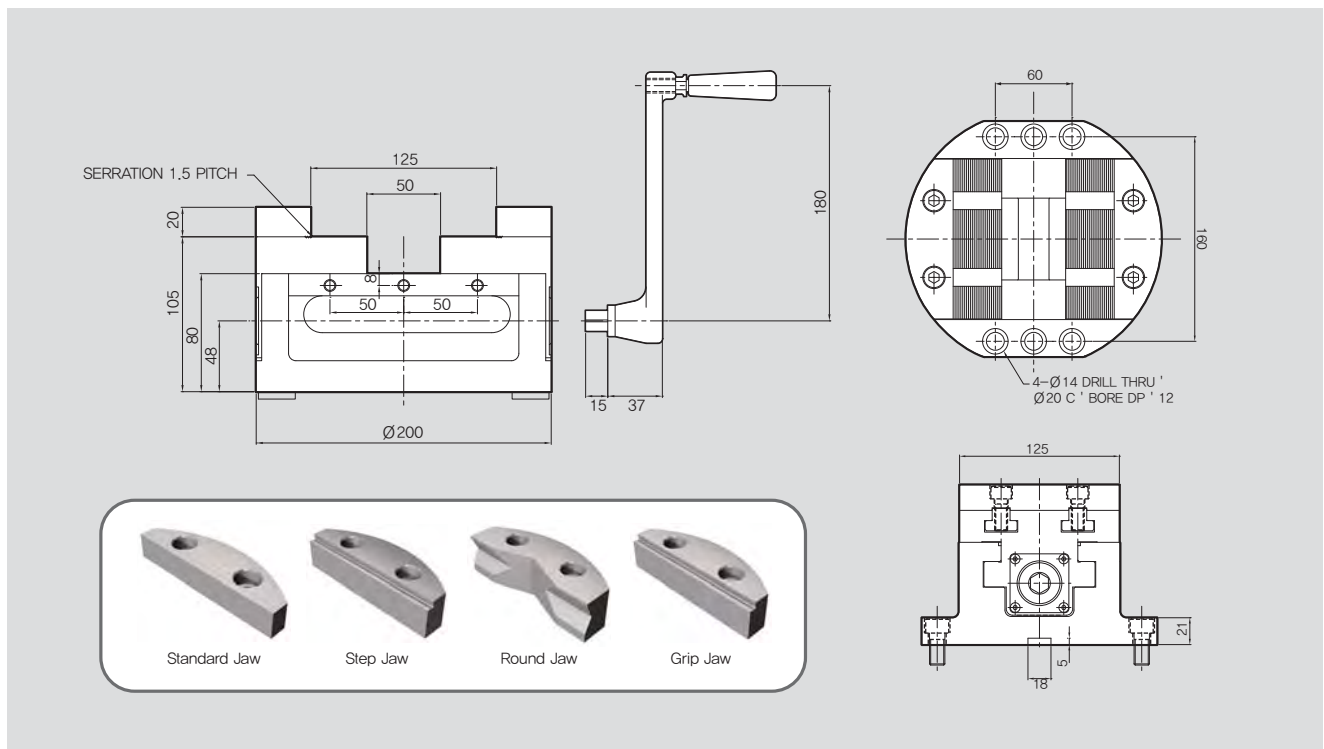

CMV-S 5-Axis Centering Vise



Application / Benefits

Self centering 5-Axis vise

Technical features

Repeats within 0.02mm or lower

Able to use a variety of jaws for various workpieces

SPECIFICATIONS

	CMV-100S	CMV-125S
Jaw Width [mm]	100	125
Jaw Height [mm]	10	10
Max. Opening [mm]	195	210
Total Height [mm]	160	185
Slider Height [mm]	150	175
Total Width [mm]	101	126
Total Length [mm]	285	332
Max.Gripping Force [kN(kgf)]	20(2000)	20(2000)
Weight [kg]	18	24

※ Specifications are subject to change without notice.

JAW ACCESSORIES

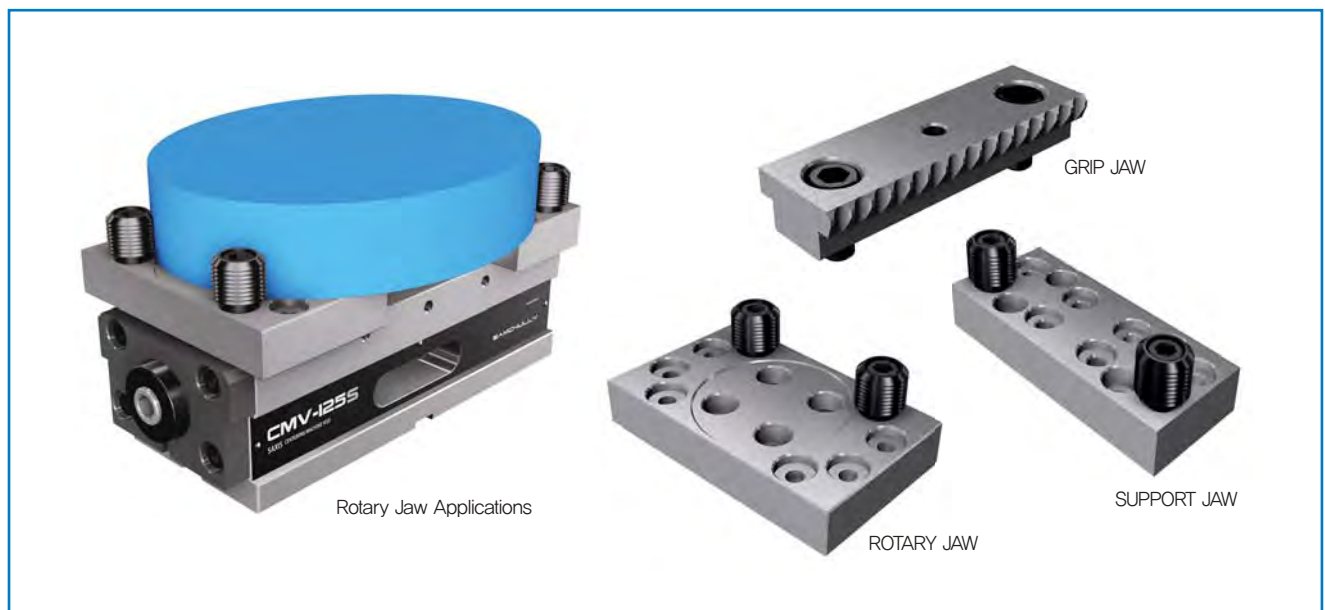

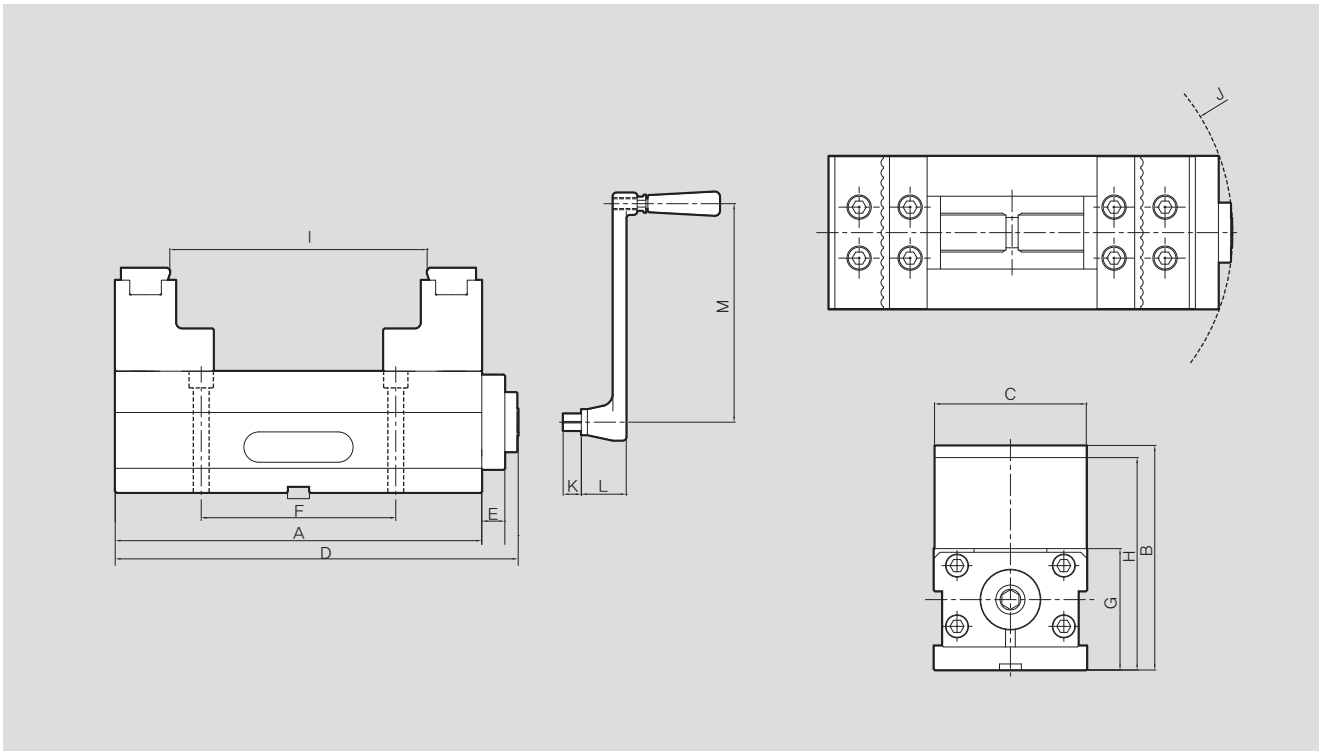

DIMENSIONS

	CMV-100S	CMV-125S
A	262	301
B	160	185
C	100	125
D	285	332
E	12	19
F	160	160
G	85	100
H	150	175
I	MAX. 195	MAX. 210
J	Φ310	Φ364
K	15	15
L	37	37
M	180	180

PCV Standard Power Vise



Application / Benefits

High precision vise with torque presetter

Technical features

Mechanically boosted torque presetter helps prevent part deformation

SPECIFICATIONS

	PCV-100 (4")	PCV-125 (5")	PCV-160 (6")	PCV-200 (8")	PCV-250 (10")
Jaw Width [mm]	100	125	160	200	250
Jaw Height [mm]	40	50	60	70	80
Max. Opening [mm]	150	230	300	320	450
Total Height [mm]	115	135	160	180	195
Slider Height [mm]	75	85	100	110	115
Total Width [mm]	107	135	170	214	264
Total Length [mm]	400	505	595	638	810
Max.Gripping Force [kN(kgf)]	25(2551)	35(3571)	60(6122)	60(6122)	80(8163)
Weight [kg]	25	43	65	100	150

※ Specifications are subject to change without notice.

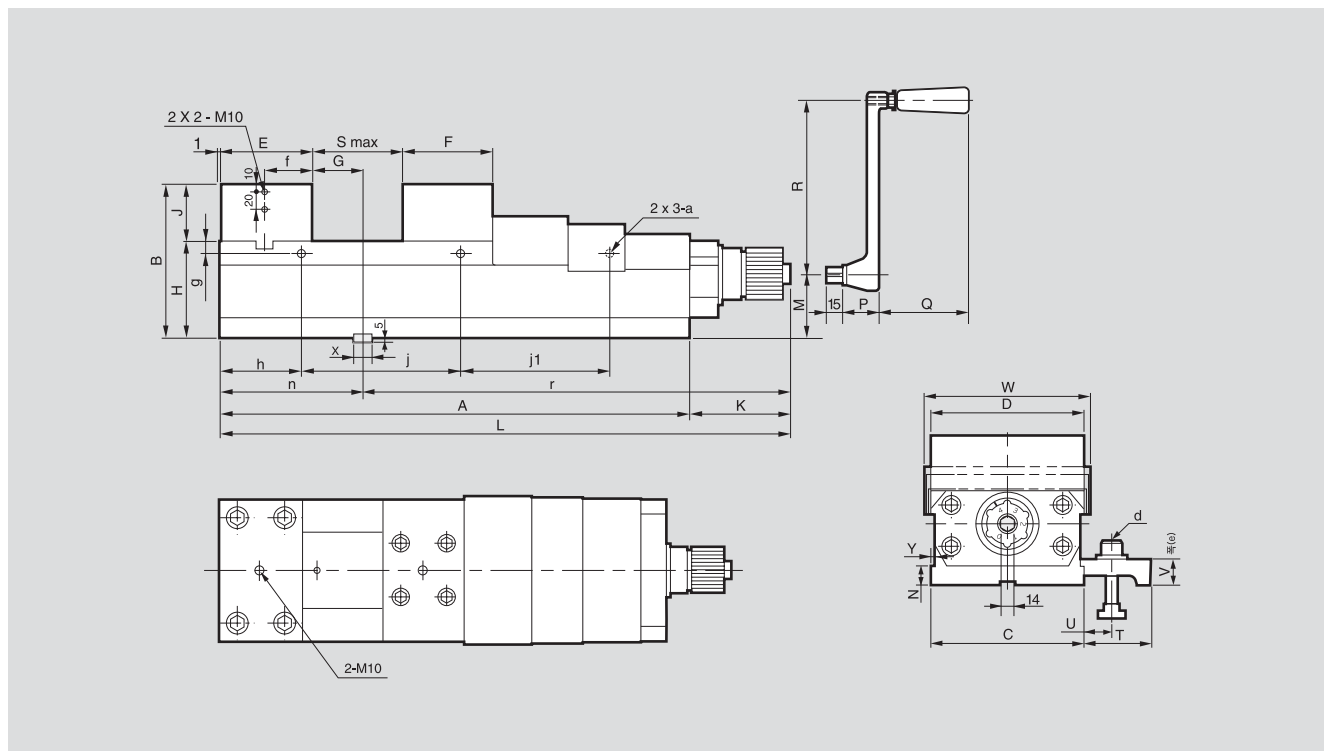

※ See the product dimension Table on the right.

DIMENSIONS

	PCV-100(4")	PCV-125(5")	PCV-160(6")	PCV-200(8")	PCV-250(10")
A	295	400	490	533	705
B	115	135	160	180	195
C	101	126	161	202	252
D	100	125	160	200	250
E	73	84	94	102	120
F	64	76	86	98	120
G	38.5	60	50	74	100
H	75	85	100	110	115
J	40	50	60	70	80
K	105.5	105.5	105.5	105.5	105.5
L	400.5	505.5	595.5	638.5	810.5
M	43	50	65	75	75
N	15	21	21	21	21
P	37	37	37	37	37
Q	95	95	95	95	95
R	180	180	180	180	180
S	150	230	300	320	450
T	60	72	72	72	72
U	14~26	15~31	15~31	15~31	15~31
V	22.5	30	30	30	30
W	107	135	170	214	267
X	14	18	18	18	22
Y	6	6	7	7	7
a	M10	M10	M10	M10	M10
b	M12x45	M16x65	M16x65	M16x65	M20x65
e	35	45	45	45	45
f	36.5	42	47	51	60
g	12	12	12	12	12
h	95	95	105	126	140
j	105	105	140	141	140
j1	-	105	140	141	140
j2	-	-	-	-	140
n	112.5	145	145	177	221
r	288.0	360.5	450.5	461.5	589.5

PSV Short-Type Power Vise



Application / Benefits

High precision vise with torque presetter
Suitable for a wide range of workpiece sizes

Technical features

Mechanically boosted torque presetter helps prevent part deformation

SPECIFICATIONS

	PSV-125(5")	PSV-160(6")
Jaw Width [mm]	125	160
Jaw Height [mm]	50	60
Max. Opening [mm]	125	160
Total Height [mm]	135	160
Slider Height [mm]	85	100
Total Width [mm]	135	170
Total Length [mm]	400.5	455.5
Max.Gripping Force [kN(kgf)]	35(3571)	60(6122)
Weight [kg]	41	62

※ Specifications are subject to change without notice.

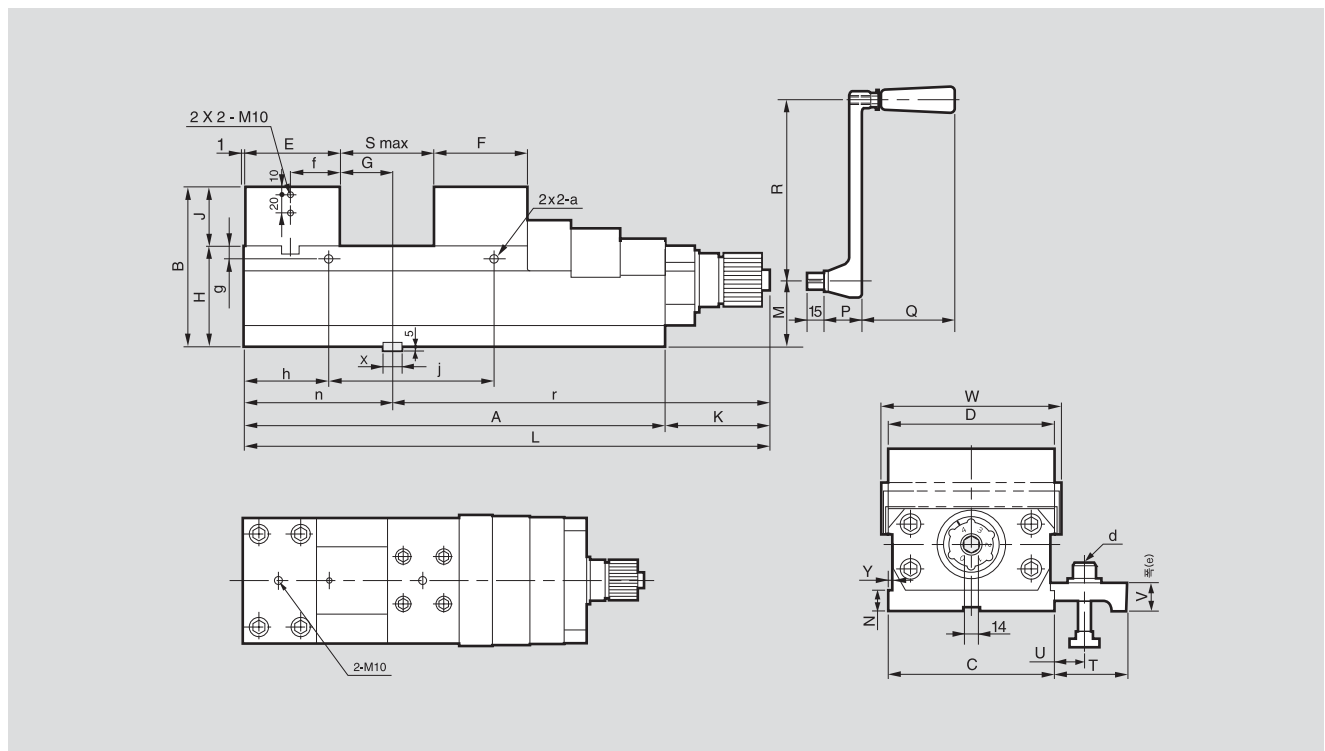

※ See the product dimension Table on the right.

DIMENSIONS

	PSV-125(5")	PSV-160(6")
A	295	350
B	135	160
C	126	161
D	125	160
E	84	94
F	76	86
G	60	50
H	85	100
J	50	60
K	105.5	105.5
L	400.5	455.5
M	50	65
N	21	21
P	37	37
Q	95	95
R	180	180
S	125	160
T	72	72
U	15~31	15~31
V	30	30
W	135	170
X	18	18
Y	6	7
a	M10	M10
b	M16x65	M16x65
e	45	45
f	42	47
g	12	12
h	95	105
j	105	140
j1	105	140
n	145	145
r	150	450.5

PLV Long Stroke Power Vise



Application / Benefits

High precision vise with torque presetter
Suitable for a wide range of workpiece sizes

Technical features

Mechanically boosted torque presetter helps prevent part deformation

SPECIFICATIONS

	PLV-125(5")	PLV-160(6")	PLV-200(8")
Jaw Width [mm]	125	160	200
Jaw Height [mm]	50	60	70
Max. Opening [mm]	230	354	405
Total Height [mm]	135	160	180
Slider Height [mm]	85	100	110
Total Width [mm]	135	170	214
Total Length [mm]	700.5	647.5	723.5
Max.Gripping Force [kN(kgf)]	35(3571)	60(6122)	60(6122)
Weight [kg]	47	70	110

※ Specifications are subject to change without notice.

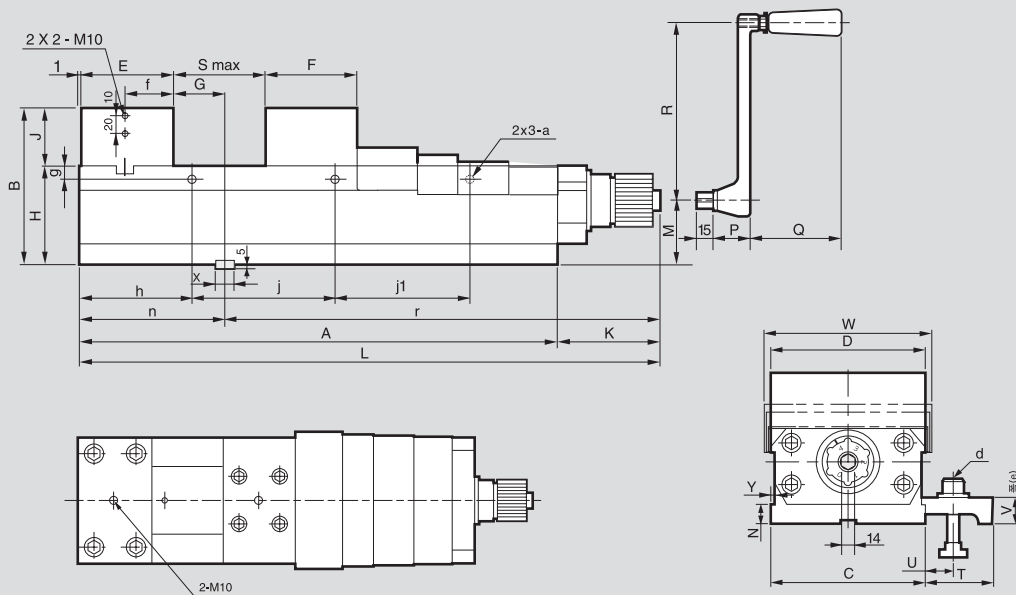

※ See the product dimension Table on the right.

DIMENSIONS

	PLV-125(5")	PLV-160(6")	PLV-200(8")
A	595	542	618
B	135	160	180
C	126	161	202
D	125	160	200
E	84	94	102
F	76	86	98
G	60	82	74
H	85	100	110
J	50	60	70
K	105.5	105.5	105.5
L	700.5	647.5	723.5
M	50	65	75
N	21	21	21
P	37	37	37
Q	95	95	95
R	180	180	180
S max	230	354	405
T	72	72	72
U	15-31	15-31	15-31
V	30	30	30
W	135	170	214
X	18	18	18
Y	6	7	7
a	M10	M10	M10
b	M16x65	M16x65	M16x65
e	45	45	45
f	42	47	51
g	12	12	12
h	95	117	126
j	202.5	150	183
j1	202.5	150	183
n	280	177	177
r	360.5	470.5	546.5

DDV Draw-Down Type Power Vise

Jaw Width Range : 160mm
Max. Opening Range : 248mm



Application / Benefits

Draw down function reduces workpiece floating

Technical features

Mechanically boosted torque presetter helps prevent part deformation (with Special Jaws)

SPECIFICATIONS

	Jaw Width [mm]	Jaw Height [mm]	Max. Opening [mm]	Total Opening [mm]	Slider Height [mm]	Total Width [mm]	Total Length [mm]	Max. Gripping Force [kN(kgf)]	Weight [kg]
DDV-160(6'')	160	60	248	160	100	170	595	60(6122)	70

※ Specifications are subject to change without notice.

DIMENSIONS

	A	B	C	D	E	F	G	H	J	J1	J2	K	L	M	N	P	Q
DDV-160(6'')	490	160	161	160	120	112	24	100	60	105.5	595.5	65	21	37	95	180	248
	T	U	V	W	X	Y	a	b	e	f	g	h	j	j1	n	r	
	72	15~31	30	170	18	7	M10	M16x65	45	47	12	105	140	140	145	450.5	

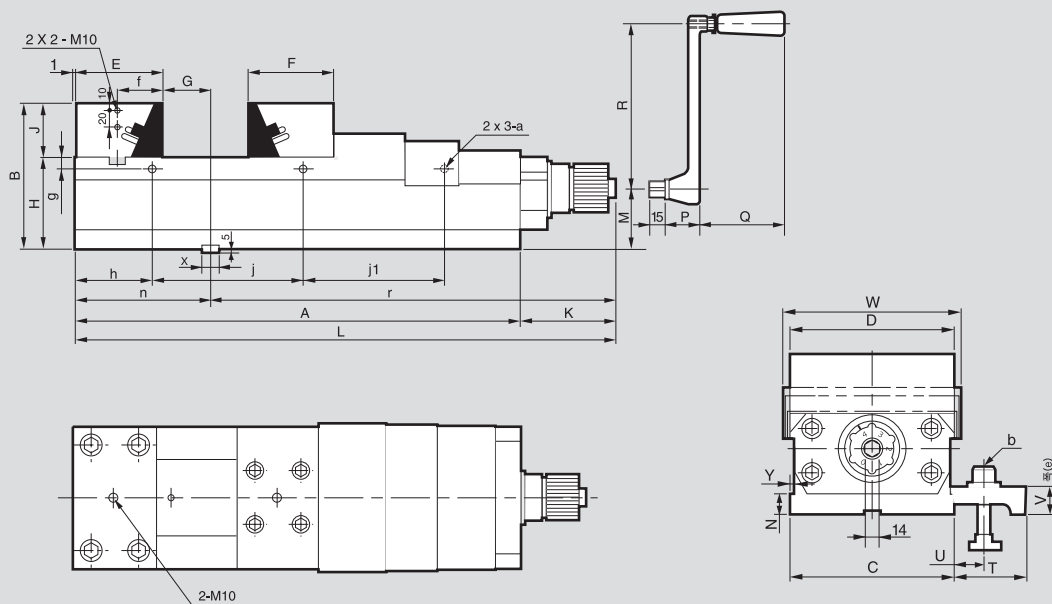

MDV Double Power Vise

Jaw Width Range : 125mm
Max. Opening Range : 141~190.5mm



Application / Benefits

Clamps two workpieces simultaneously.

Technical features

Mechanically boosted torque presetter helps prevent part deformation.
3mm compensations facilitates loading and mitigates workpiece variance.

SPECIFICATIONS

	Jaw Width [mm]	Jaw Height [mm]	Max. Opening [mm]				Total Opening [mm]	Slider Height [mm]	Total Width [mm]	Total Length [mm]	Max. Gripping Force [kN(kgf)]	Weight [kg]
MDV-125	125	40	S1	S2	S3	S4	145	105	126	671	40(4355)	52
			141	144.5	187	190.5						

※ Specifications are subject to change without notice.

DIMENSIONS

	A	B	C	D	E	F	G	H	J	J1	J2	K	L	M	N	P	Q	R	T
MDV-125	495	145	126	125	40	75	-	105	40	20	45	176	671	50	15	37	94	180	72
	U	V	W	X	Y	a	d	e	f	g	h	j	n	r	t	y	z	z1	w
	15~31	30.5	126	18	6	M10	M16x65L	42	37	20	205	90	250	421	355	98	11	17.5	10

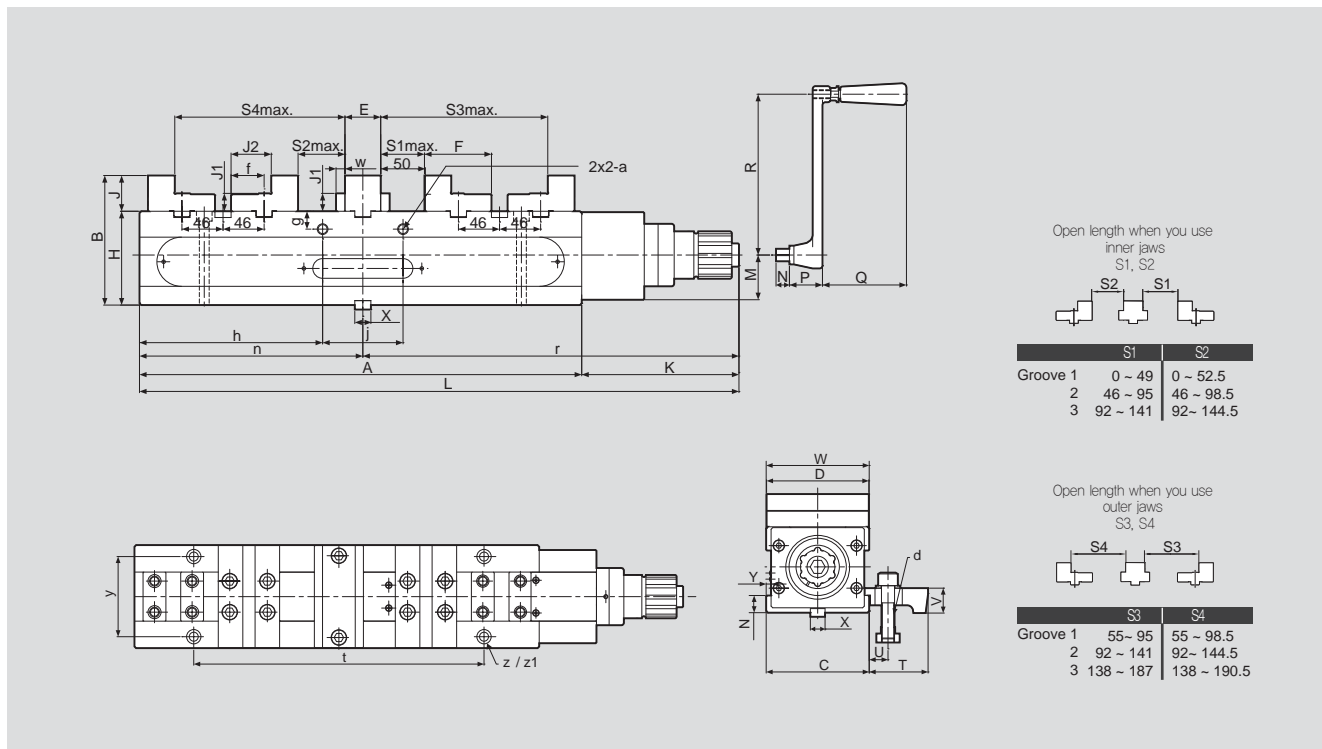



Application / Benefits

Multi clamping.

Technical features

Serrated jaws may be repositioned. Minimizes deformation.

SPECIFICATIONS

	Jaw Width [mm]	Jaw Height [mm]	Maw. Opening [mm]				Total Opening [mm]	Slider Height [mm]	Total Width [mm]	Total Length [mm]	Max. Gripping Force [kN(kgf)]	Weight [kg]
FV5060	50	25	S1	S2	S3	S4	75	50	50	600	-	15
			500	215	120	75						

※ Specifications are subject to change without notice.

DIMENSIONS

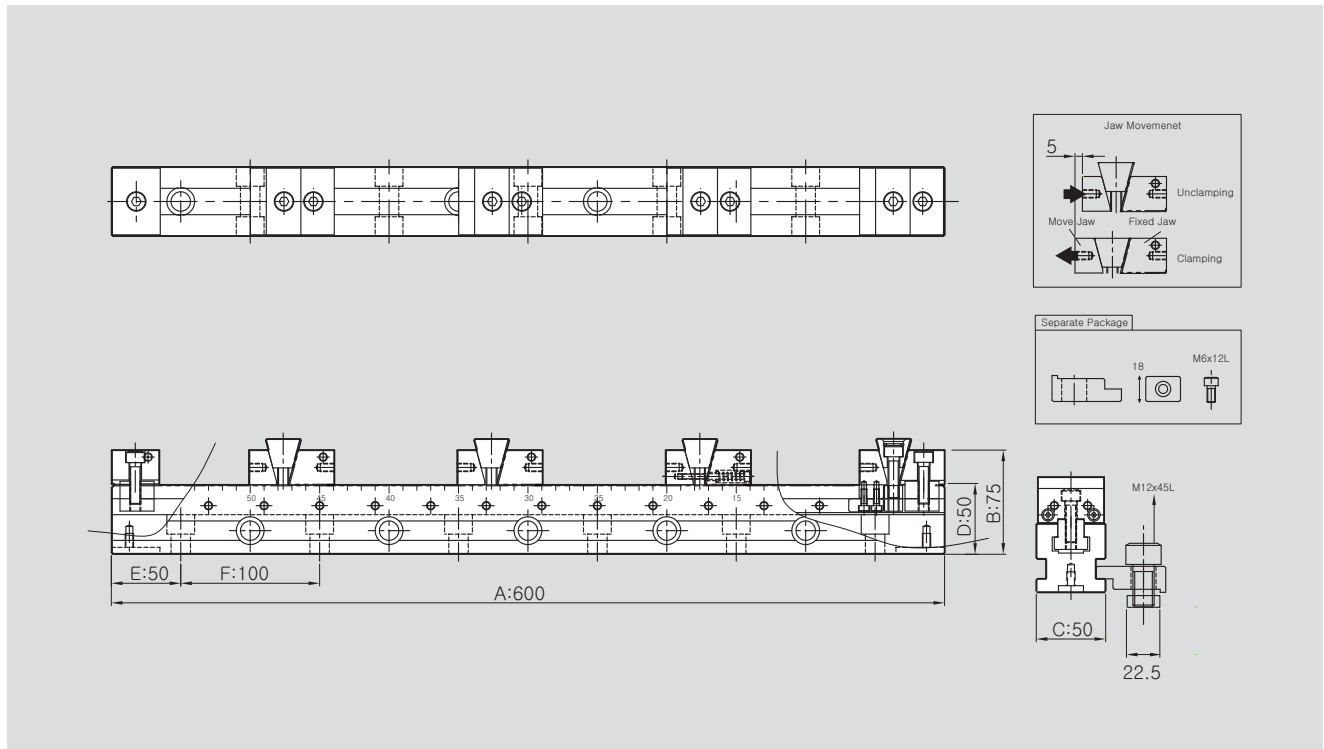

※ See the product dimension Table on the right.

CLAMPING RANGE

1EA Clamping

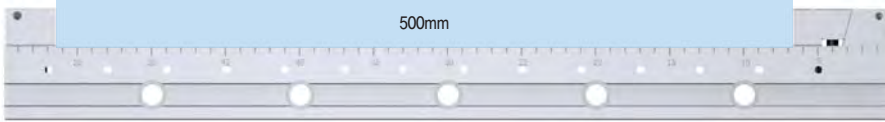

2EA Clamping



3EA Clamping



4EA Clamping



Max. Clamping Range



VS Standard Machine Vise



Application / Benefits

High precision machine vise

Technical features

Special hardened material used

SPECIFICATIONS

	VS-150(6")	VS-175(7")	VS-200(8")	VS-250(10")
Body [kg]	34	46.7	57.5	110
Table [kg]	10.8	14.5	20.5	36.5
Max. Opening [mm]	110	132	160	199
Operating Swivel Base	SB-150T	SB-175T	SB-200T	SB-250T
Mounting Key Size	34x16x10	34x16x10	36x20x12	36x20x12

※ Specifications are subject to change without notice.

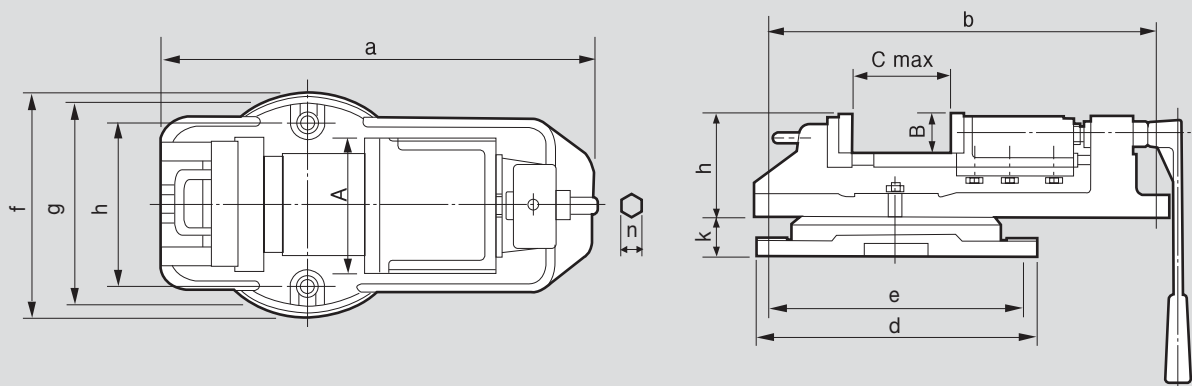

※ See the product dimension Table on the right.

DIMENSIONS

	VS-150(6")	VS-175(7")	VS-200(8")	VS-250(10")
A	150	175	200	250
B	45	50	55	75
C	110	132	160	199
a	470	547	618	760
b	440	518	573	716
c	320	350	400	450
d	288	318	358	406
e	245	280	316	370
f	220	245	280	332
g	180	198	228	278
h	115	120	130	168
i	45	50	55	60
j	283	340	340	380
k	18	21	21	22

MMV Mechanical Machine Quick Vise



Application / Benefits

Mechanical Machine Vise with no oil leak.

Technical features

Mechanically boosted torque presetter helps prevent part deformation

SPECIFICATIONS

	MMV-150Q(6")	MMV-200Q(8")
Max. Grip Torque [kg]	4,400	6,500
Body [kg]	56.0	94.0
Max. Opening [mm]	300	300
Table [kg]	16.0	23.0
Operating Swivel Base	VS-175T	VS-200T
Mounting Key Size	34x16x10	36x20x12

※ Specifications are subject to change without notice.

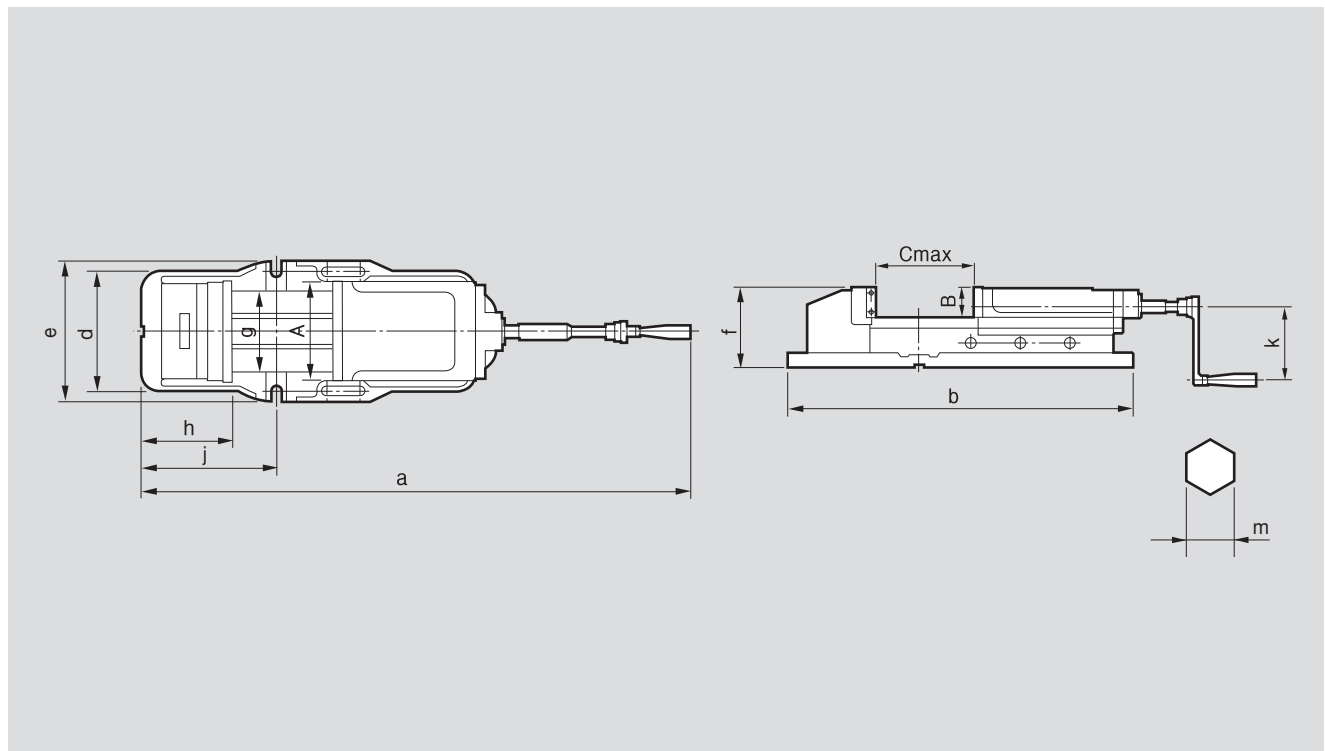

※ See the product dimension Table on the right.

DIMENSIONS

	MMV-150Q(6")	MMV-200Q(8")
A	150	200
B	51	62
C	300	300
a	800	900
b	620	700
c	200	240
d	240	280
e	133	162
g	116	160
h	125	165
i	210	266
j	130	130
k	19	19
Max. Grip Torque [kg]	4,400	6,500

APV Air Vise



Application / Benefits

Pneumatic clamping

Technical features

Control pressure with a dial

SPECIFICATIONS

	APV-125	APV-160
Jaw Width [mm]	125	160
Jaw Height [mm]	60	60
Max. Opening [mm]	188	165
Total Height [mm]	150	160
Slider Height [mm]	100	100
Total Width [mm]	166	199
Total Length [mm]	585	584
Max.Gripping Force [kN(kgf)]	35(3500)	60(6000)
Weight [kg]	55	63

※ Specifications are subject to change without notice.

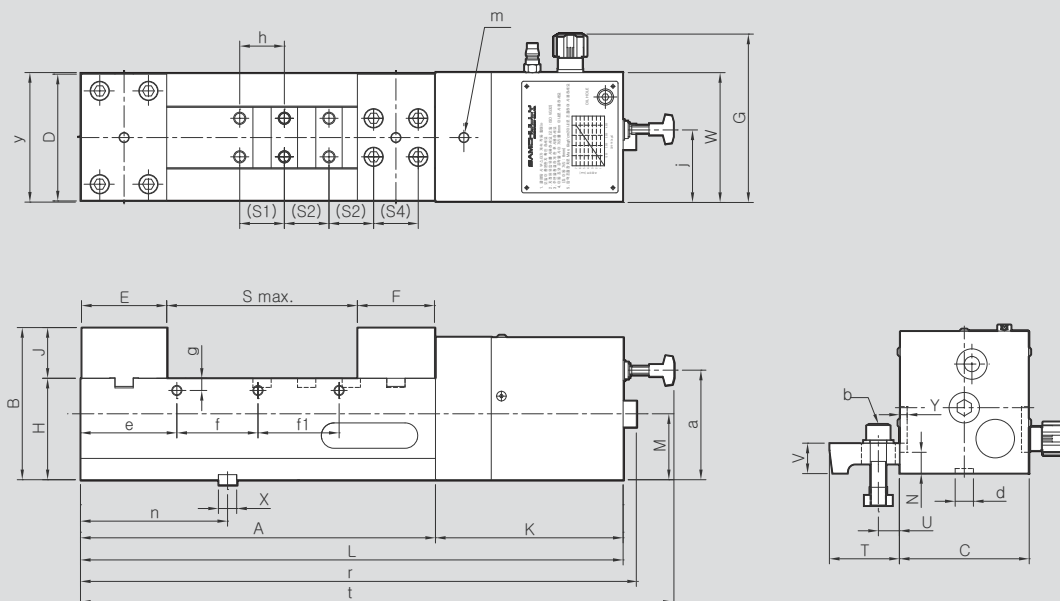

※ See the product dimension Table on the right.

DIMENSIONS

	APV-125	APV-160
A	350	350
B	150	160
C	128	161
D	125	160
E	84	94
F	76	86
G	166	199
H	100	100
J	50	60
K	185	185
L	535	535
M	65	65
N	21	21
S max	188	165
T	69	72
U	15~30	23
V	30	30.5
W	128	163.8
X	18	18
Y	7	7
a	108	97
b	M16X65L	M16X16L
d	18	18
e	95	105
f	80	140
g	12	12
h	44	50
j	71.5	100
n	145	145
r	548	548
t	585	584



MAGNET CHUCK

Providing uniform clamping and minimizing deformation,
our magnetic chucks deliver the accuracy and increased efficiency every
milling machine needs.



EP

Electro Permanent
Magnetic Chuck
(50x50mm Pole)

244 P



FEC

Electro Magnetic
Chuck (Fine Pitch
Models)

246 P



PEC

Premium Electro
Magnetic Chuck
(Fine Pitch Models)

248 P



MSC

Permanent Magnetic
Chuck

250 P



MOC

Permanent Magnetic
Chuck

252 P

EP Electro Permanent Magnetic Chuck

Pole Size : 50X50mm



Application / Benefits

Suitable 5-face machining

Technical features

Strong magnetic clamping, Low heating
Low residual magnetism

Model No.

EP-53025

외곽 사이즈 / Body Size
Pole 사이즈 / Pole Size

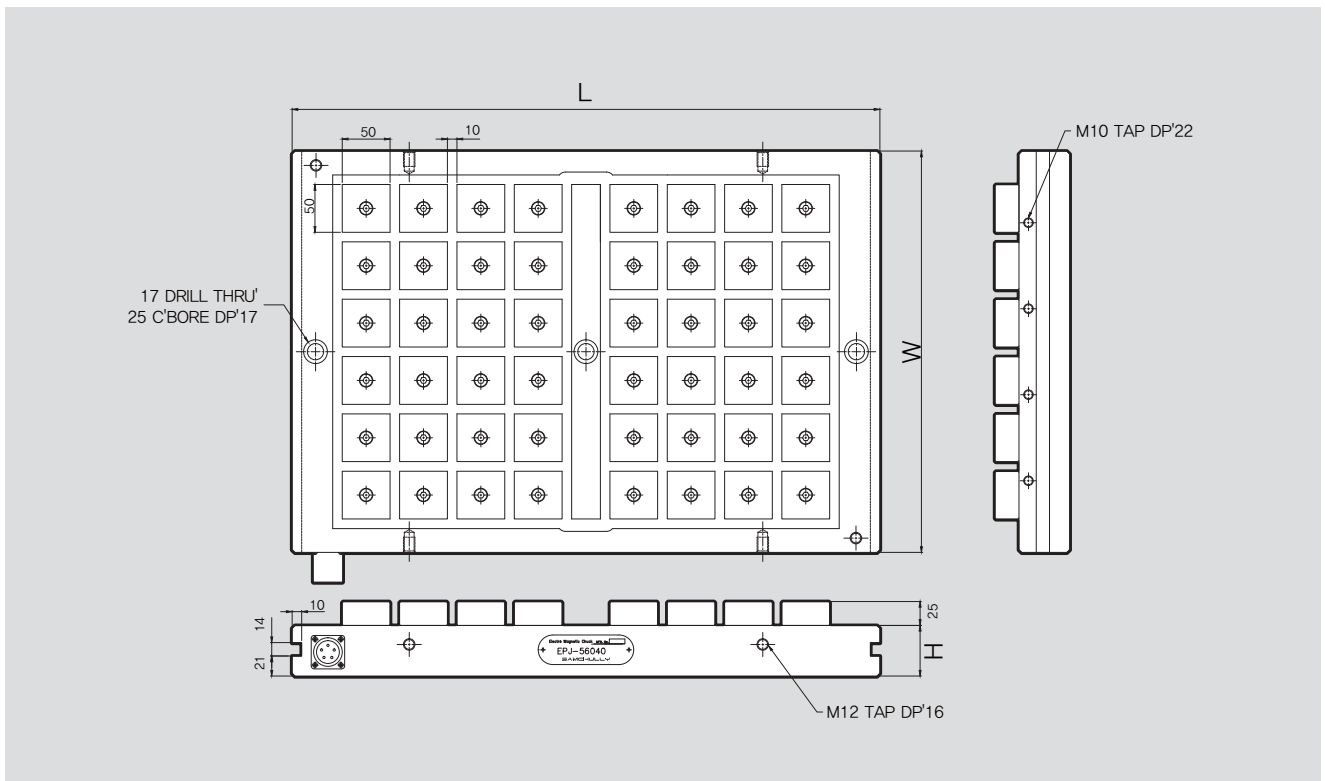

- ※ See the product dimension Table on the right.
- ※ Specifications are subject to change without notice.

SPECIFICATIONS

	EP-53025	EP-55025	EP-56025	EP-57025	EP-59025*	EP-510025*
Pole Size [mm]	50 x 50	50 x 50	50 x 50	50 x 50	50 x 50	50 x 50
Total Length [mm]	240	240	240	240	240	240
Total Width [mm]	335	490	615	735	915	1035
Total Height [mm]	53	53	53	53	53	53
Number of Poles [ea]	12	18	24	30	36	42
Power Supply	AC 220V (단상)	AC 220V (단상)	AC 220V (단상)	AC 220V (단상)	AC 220V (단상)	AC 220V (단상)
Weight [kg]	40	59	76	92	113	130

	EP-53030	EP-55030	EP-56030	EP-57030	EP-59030*	EP-510030*
Pole Size [mm]	50 x 50	50 x 50	50 x 50	50 x 50	50 x 50	50 x 50
Total Length [mm]	300	300	300	300	300	300
Total Width [mm]	335	490	615	735	915	1035
Total Height [mm]	53	53	53	53	53	53
Number of Poles [ea]	16	24	32	40	48	56
Power Supply	AC 220V (단상)	AC 220V (단상)	AC 220V (단상)	AC 220V (단상)	AC 220V (단상)	AC 220V (단상)
Weight [kg]	47	70	89	104	130	147

	EP-53040	EP-55040	EP-56040	EP-57040	EP-59040*	EP-510040*
Pole Size	50 x 50	50 x 50	50 x 50	50 x 50	50 x 50	50 x 50
Total Length	420	420	420	420	420	420
Total Width	335	490	610	735	915	1035
Total Height	53	53	53	53	53	53
Number of Poles	24	36	48	60	72	84
Power Supply	AC 220V (단상)	AC 220V (단상)	AC 220V (단상)	AC 220V (단상)	AC 220V (단상)	AC 220V (단상)
Weight	64	94	119	145	179	203

	EP-53050	EP-55050	EP-56050	EP-57050	EP-59050*	EP-510050*
Pole Size [mm]	50 x 50	50 x 50	50 x 50	50 x 50	50 x 50	50 x 50
Total Length [mm]	480	480	480	480	480	480
Total Width [mm]	335	490	615	735	915	1035
Total Height [mm]	53	53	53	53	53	53
Number of Poles [ea]	28	42	56	70	84	98
Power Supply	AC 220V (단상)	AC 220V (단상)	AC 220V (단상)	AC 220V (단상)	AC 220V (단상)	AC 220V (단상)
Weight [kg]	74	107	136	164	204	230

	EP-53060	EP-55060	EP-56060	EP-57060	EP-590560*	EP-510060*
Pole Size [mm]	50 x 50	50 x 50	50 x 50	50 x 50	50 x 50	50 x 50
Total Length [mm]	600	600	600	600	600	600
Total Width [mm]	335	490	615	735	915	1035
Total Height [mm]	53	53	53	53	53	53
Number of Poles [ea]	36	54	72	90	108	126
Power Supply	AC 220V (단상)	AC 220V (단상)	AC 220V (단상)	AC 220V (단상)	AC 220V (단상)	AC 220V (단상)
Weight [kg]	91	132	169	203	253	286

- ※ Controller Neocon-M is basic components for Standard model.
- ※ Available option : Neocon-M4(4Channel).
- ※ Controller Neocon-M4(4Channel) is basic components for [*]mark model.

FEC Electro Magnetic Chuck



Application / Benefits

Suitable for surface grinding (Mold / Die set / Steel part)
 Improved accuracy, Easy to control the magnetic force for the shear materials and various processing steps.
 Perfect surface treatment and waterproof durability

Technical features

By applying multi-coil, forming a uniform magnetic force
 Improved performance for Low residual magnetism

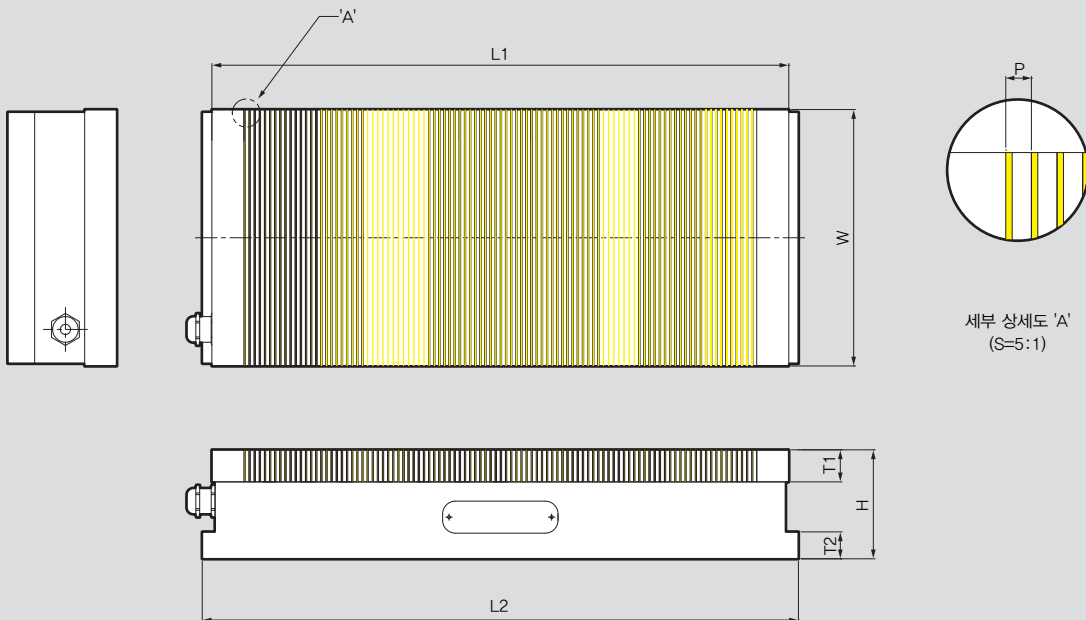

※ See the product dimension Table on the right.

SPECIFICATIONS

	FEC-1530	FEC-1535	FEC-1540	FEC-2040	FEC-2045
Pole Pitch [mm]	1+3	1+3	1+3	1+3	1+3
Total Length(W) [mm]	150	150	150	200	200
Base Width(L2) [mm]	315	365	415	415	465
Base Height(T2) [mm]	21	21	21	21	21
Total Height(H) [mm]	85	85	85	85	85
Upper Width(L1) [mm]	300	350	400	400	450
Upper Height(T1) [mm]	25	25	25	25	25
Power Supply(V)	AC 220V (단상)	AC 220V (단상)	AC 220V (단상)	AC 220V (단상)	AC 220V (단상)
Output Voltage(V)	DC95	DC95	DC95	DC95	DC95
Weight [Kg]	25	28	32	42	47

	FEC-2050	FEC-2060	FEC-3050	FEC-3060
Pole Pitch [mm]	1+3	1+3	1+3	1+3
Total Length(W) [mm]	200	200	300	300
Base Width(L2) [mm]	515	615	515	615
Base Height(T2) [mm]	21	21	21	21
Total Height(H) [mm]	85	85	85	85
Upper Width(L1) [mm]	500	600	500	600
Upper Height(T1) [mm]	25	25	25	25
Power Supply(V)	AC 220V (단상)	AC 220V (단상)	AC 220V (단상)	AC 220V (단상)
Output Voltage(V)	DC95	DC95	DC95	DC95
Weight [Kg]	52	62	88	98

- ※ Controller "Neocon-E" is basic components.
- ※ Specifications are subject to change without notice.

PEC Premium Electro Magnetic Chuck



Application / Benefits

Suitable for surface grinding (Mold/Die set/Steel part)
 Save the loaded/unloaded time for workpiece
 No heat generated
 Perfect surface treatment and waterproof for durability

Technical features

Uniform magnetic power by multi-coil
 Improved performance for low residual magnetism
 Build in magnet to prevent a power failure

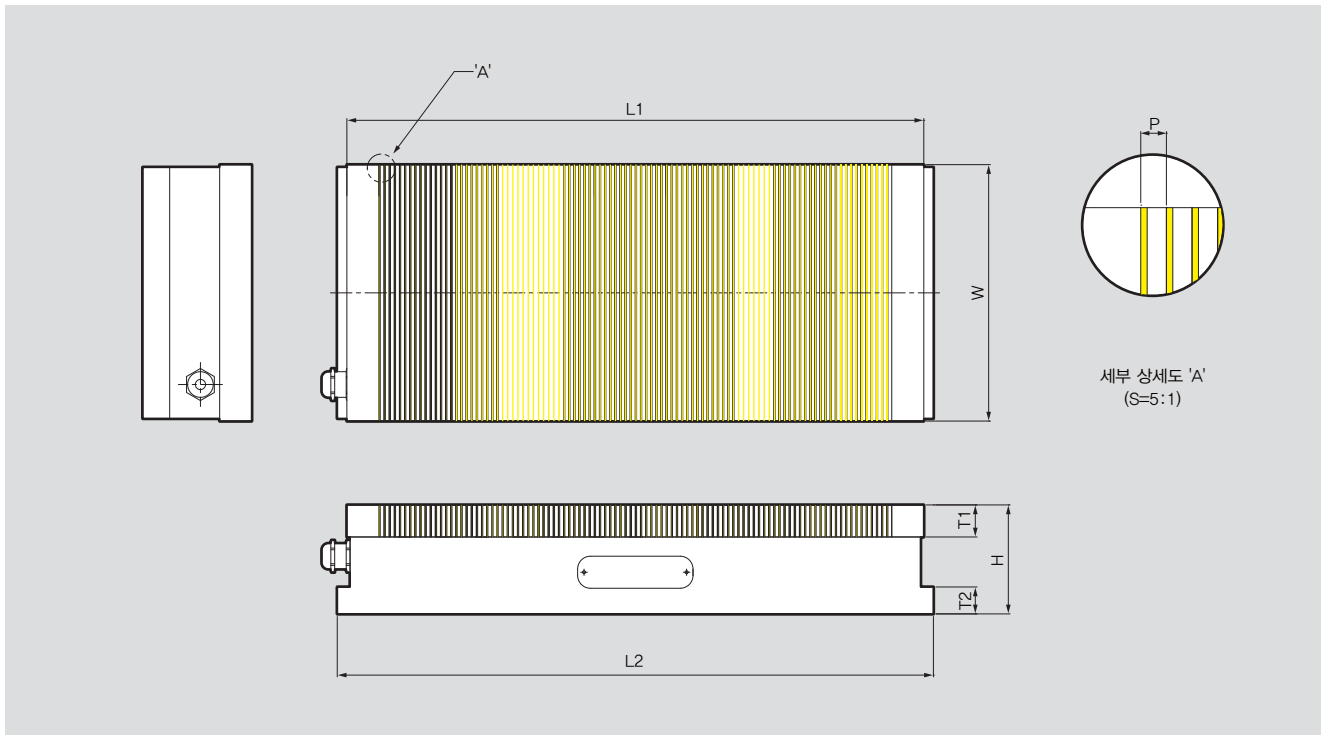

※ See the product dimension Table on the right.

SPECIFICATIONS

	PEC-1530	PEC-1535	PEC-1540	PEC-2040	PEC-2045
Pole Pitch [mm]	1+3	1+3	1+3	1+3	1+3
Total Length(W) [mm]	150	150	150	200	200
Base Width(L2) [mm]	315	365	415	415	465
Base Height(T2) [mm]	21	21	21	21	21
Total Height(H) [mm]	85	85	85	85	85
Upper Width(L1) [mm]	300	350	400	400	450
Upper Height(T1) [mm]	25	25	25	25	25
Power Supply (V)	AC 220V (단상)	AC 220V (단상)	AC 220V (단상)	AC 220V (단상)	AC 220V (단상)
Output Voltage (V)	DC95	DC95	DC95	DC95	DC95
Weight [kg]	25	28	32	42	47

	PEC-2050	PEC-2060	PEC-3050	PEC-3060
Pole Pitch [mm]	1+3	1+3	1+3	1+3
Total Length(W) [mm]	200	200	300	300
Base Width(L2) [mm]	515	615	515	615
Base Height(T2) [mm]	21	21	21	21
Total Height(H) [mm]	85	85	85	85
Upper Width(L1) [mm]	500	600	500	600
Upper Height(T1) [mm]	25	25	25	25
Power Supply (V)	AC 220V (단상)	AC 220V (단상)	AC 220V (단상)	AC 220V (단상)
Output Voltage (V)	DC95	DC95	DC95	DC95
Weight [kg]	52	62	88	98

- ※ Controller "Neocon-E" is basic components.
- ※ Specifications are subject to change without notice.

MSC Permanent Magnetic Chuck



Application / Benefits

- Unnecessary power source
- Uniform magnetic power by manual operation
- No heat generated
- Suitable for grinder, electric discharge machine

Technical features

- Fine pitch grinding of small and thin workpieces

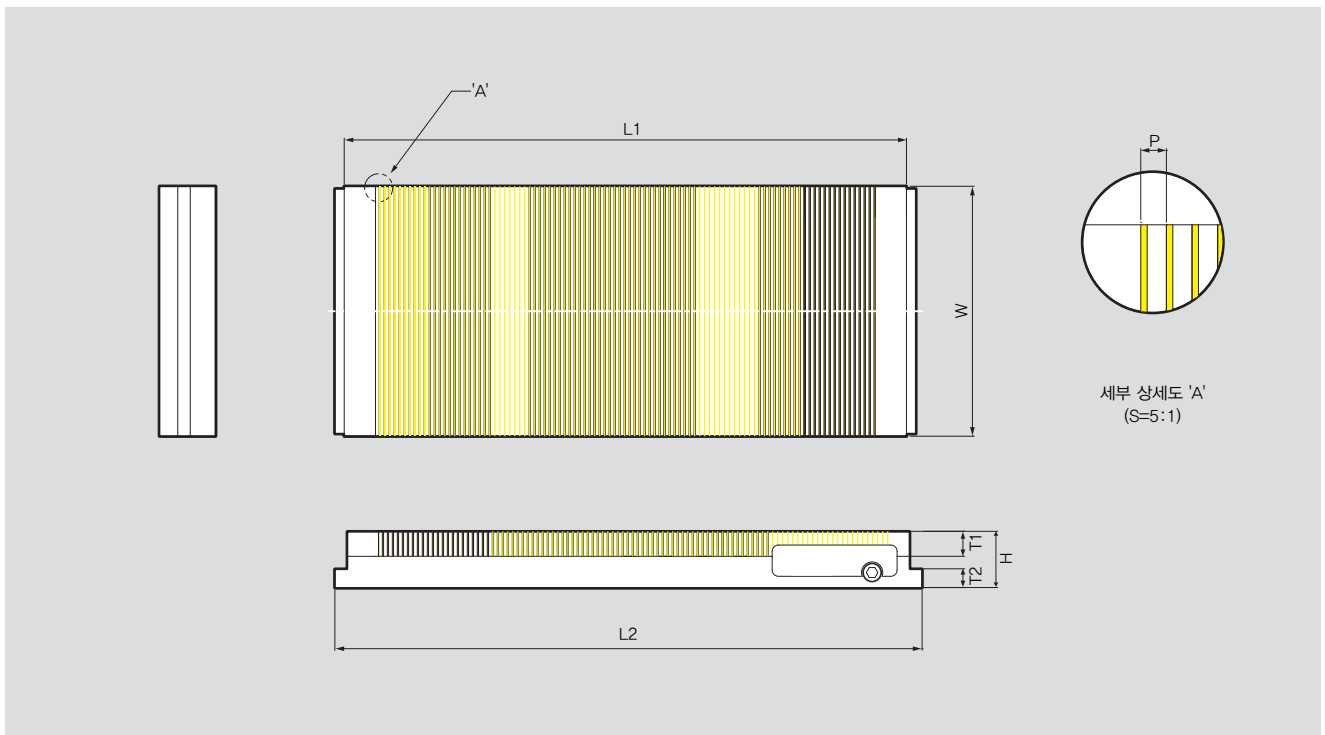

※ See the product dimension Table on the right.

SPECIFICATIONS

	MSC-1018	MSC-1325	MSC-1530	MSC-1545	MSC-2040
Pole Pitch [mm]	1+3	1+3	1+3	1+3	1+3
Total Length(W) [mm]	105	130	150	150	200
Base Width(L2) [mm]	195	270	320	470	420
Base Height(T2) [mm]	21	21	21	21	21
Total Height(H) [mm]	45	45	45	45	45
Upper Width(L1) [mm]	175	250	300	450	400
Upper Height(T1) [mm]	25	25	25	25	25
Weight [kg]	7	12	17	25	30

	MSC-2050	MSC-2060	MSC-3050	MSC-3060
Pole Pitch [mm]	1+3	1+3	1+3	1+3
Total Length(W) [mm]	200	200	300	300
Base Width(L2) [mm]	520	620	520	620
Base Height(T2) [mm]	21	21	21	21
Total Height(H) [mm]	45	45	45	45
Upper Width(L1) [mm]	500	600	500	600
Upper Height(T1) [mm]	25	25	25	25
Weight [kg]	40	48	60	72

※ Specifications are subject to change without notice.

MOC Permanent Magnetic Chuck



Application / Benefits

- Unnecessary power source
- Uniform magnetic power by manual operation
- No heat generated
- Suitable for grinder, electric discharge machine

Technical features

- Fine pitch grinding of small and thin workpieces

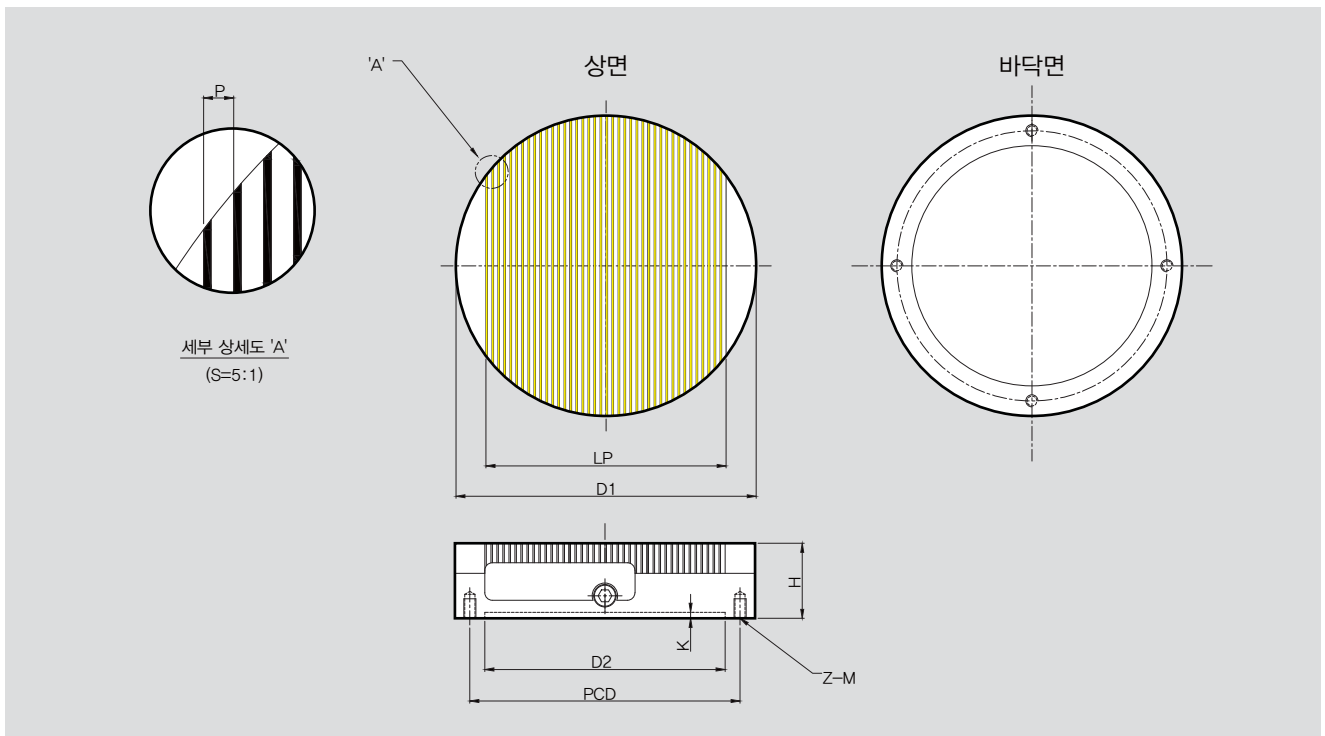

※ See the product dimension Table on the right.

SPECIFICATIONS

	MOC-160	MOC-200	MOC-250	MOC-300
Pole Pitch [mm]	1+3	1+3	1+3	1+3
Total Length(D1) [mm]	160	200	250	300
Pole Pitch Width(LP) [mm]	120	160	210	260
Total Height(H) [mm]	50	50	50	50
Base Width(D2) [mm]	125	160	220	260
Base Height(K) [mm]	4	4	4	4
PCD [mm]	140	180	220	260
Z-M	4-M8	4-M8	4-M10	4-M10
Weight [kg]	8	12	20	32

※ Specifications are subject to change without notice.



ACCESSORIES

Good stock levels and in-house production of all accessories show how committed we are to aftermarket support.



Soft Jaw

Power Chuck
Soft Jaw

256 P



Hard Jaw

Power Chuck
Hard Jaw

258 P



T-Nut

Power Chuck
T-Nut

260 P



Adaptor

Power Chuck
Adaptor Plates

262 P



QJC Jaw

Quick Jaw Change
Chuck Jaws

264 P



TC, FTC Jaw

Scroll Chuck Jaws

266 P



SC, IC Jaw

Scroll Chuck Jaws

267 P



Etc.

Scroll Chuck
Accessories

268 P

Soft Jaw

Power Chuck Soft Jaw



Application / Benefits

Works with HC.

Fig. 1

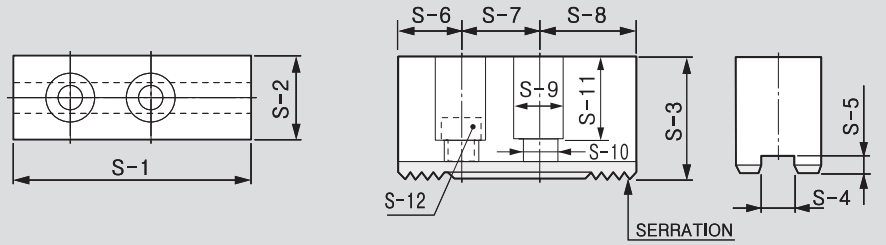

Fig. 2

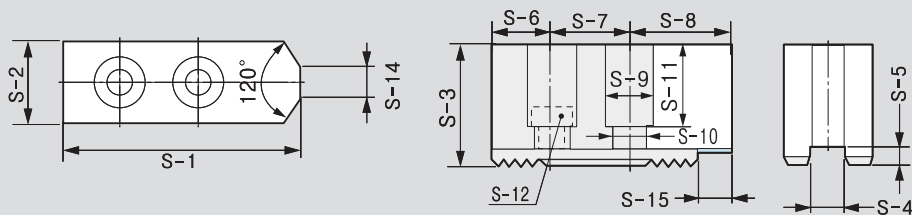
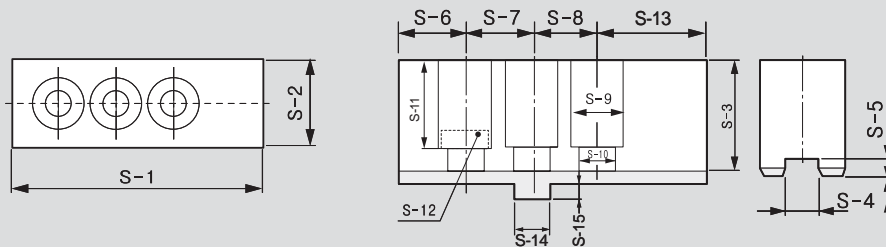

Fig. 3



※ See the product dimension Table on the right.

DIMENSIONS

	SB04C1	SB05N1	SB06B1	SB08B1	SB10B1	SB12A1	SB12N1	SB15C1
Fig.	2	2	2	2	2	1	1	1
Serration Pitch	1.5x60°	1.5x60°	1.5x60°	1.5x60°	1.5x60°	1.5x60°	1.5x60°	1.5x60°
S-1	48	54	72	95	110	129	111	165
S-2	19	23	31	35	40	50	50	62
S-3	23	25	32	38	42	50	50	66
S-4	8	10	12	14	16	18	21	22
S-5	3	4	5	5	5	5	4	8
S-6	8	12	15	24	30	39	21	37
S-7	15	14	20	25	30	30	30	43
S-8	25	28	37	46	50	60	60	85
S-9	11	13.5	17	19	19	23	25	32
S-10	7	8.5	11	13	13	15	17	21
S-11	15	16.5	20	23	27	30	33	42
S-12	M6x16	M8x20	M10x30	M12x35	M12x35	M14x45	M16x40	M20x60
S-13	-	-	-	-	-	-	-	-
S-14	6	5	12	12	15	-	-	-
S-15	-	-	-	-	20	-	-	-
Corresponding	HCH-04	HS/HC-04,05	HS/HCH/HC-06, MH-206, UR-175	HCH/HC/HS-08, MH-208, UR-210	HCH/HC/HS-10, MH-210, UR-250	HC/HCH-12	HS-12, MH-212 UR-315	HCH-15 HCH-18

	SB15N1	SB15A2	SB18A2	SB32B2	SB32GB	SB32SB2	SB40GB	SB40SB2
Fig.	1	1	1	1	3	1	3	1
Serration Pitch	1.5x60°	3.0x60°	3.0x60°	3.0x60°	-	3.0x60°	-	3.0x60°
S-1	135	165	180	160	165	185	270	270
S-2	50	62	65	75	75	75	110	110
S-3	60	66	70	75	83	75	117	110
S-4	25.5	22	25	25.5	12.7	25.5	30	30
S-5	5	8	9	7	13	7.5	13	7.5
S-6	26	30	40	25	21.9	26.8	48.8	32.5
S-7	43	50	60	38	76.2	38.1	76.2	60
S-8	66	85	80	97	-	82	76.2	-
S-9	32	32	32	32	32	32	39	39
S-10	21	21	21	22	22	22	26	26
S-11	39	42	45	54	59	57	90	90
S-12	M20x55	M20x60	M20x60	M20	M20	M20	M24	M24
S-13	-	-	-	-	-	82	68.8	117.5
S-14	-	-	-	-	19.025	-	19.025	-
S-15	-	-	-	-	-	-	-	85
Corresponding	HC-15, HC-18	MH-218	HC/HCH-21, HC/HCH-24, MH-221,224	HCH-32 [Serration]	HC-32 [Groove]	HC-32S [Serration]	HC-40 [Groove] /50,55,63,70,80	HC-40 [Serration] /50,55,63,70,80

Hard Jaw

Power Chuck Hard Jaw



Application / Benefits

Works with HC.

Fig. 1

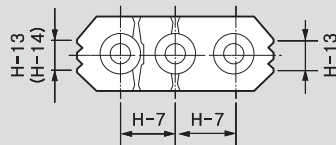

Fig. 2

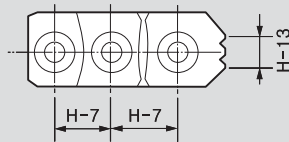
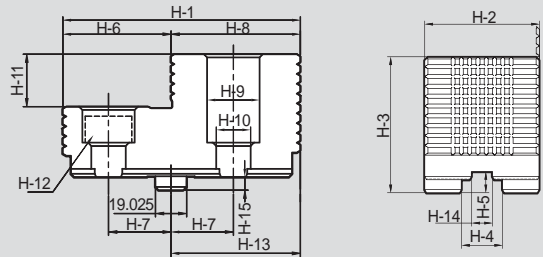
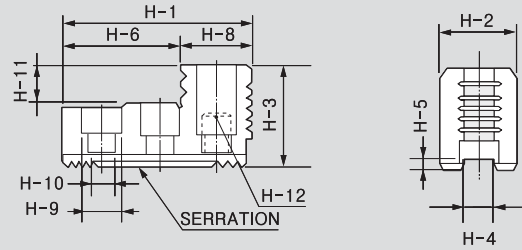
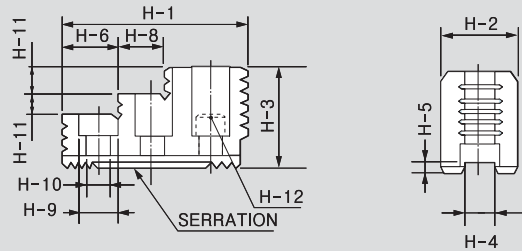
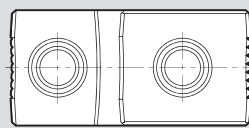

Fig. 3



※ See the product dimension Table on the right.

DIMENSIONS

	HB04N1	HB06A1	HB08A1	HB10A1	HB12B1	HB12N1	HB15A1	HB15A2
Fig.	2	1	1	1	2	2	1	1
Serration Pitch	1.5x60°	1.5x60°	1.5x60°	1.5x60°	1.5x60°	1.5x60°	1.5x60°	3.0x60°
H-1	53	67	86	99.5	97.5	103	149	149
H-2	23	31	35	40	50	50	62	62
H-3	27.5	41	51	54	55	52	86	86
H-4	10	12	14	16	18	21	22	22
H-5	4	5	5	5	5	4	9	9
H-6	30.5	18	31	43	64.5	62.5	63	63
H-7	14	20	25	30	30	30	43	50
H-8	22.5	17	18	17	33	40.5	34	34
H-9	13.5	17	19	19	22	25	32	32
H-10	8.5	11	13	13	15	17	21	21
H-11	10	9	12	13	20	17	20	20
H-12	M8	M10	M12	M12	M14	M16	M20	M20
H-13	6	10	12	15	18	30	40	40
H-14	-	10	12	15	-	-	40	40
H-15	-	-	-	-	-	-	-	-
Corresponding	HS-04, HS-05	HC/HCH/HS-06, MH-206, UR-175	HC/HCH/HS-08, MH-208, UR-210	HC/HCH/HS-10, MH-210, UR-250	HC/HCH-12	HS-12, MH-212 UR-315	HCH-15, HCH-18	MH-218

	HB15N1	HB18B2	HB32B2	HB32GB	HB32SB2	HB40GB	HB40SB2	-
Fig.	1	2	2	3	2	3	2	-
Serration Pitch	1.5x60°	3.0x60°	3.0x60°	-	3.0x60°	-	3.0x60°	-
H-1	149	159.5	150	150	168	223	223	-
H-2	62	80	70	70	70	80	80	-
H-3	86	90	75	83	75	124	117	-
H-4	25.5	25	25.5	25	25.5	30	30	-
H-5	5	9	7	13	7.5	15	8	-
H-6	69	104.5	66	66	89	133	133	-
H-7	43	50	76.2	38.1	38.1	38.1	114.3	-
H-8	27	55	79	79	79	90	90	-
H-9	32	32	32	32	32	39	39	-
H-10	21	21	21	21	21	26	26	-
H-11	20	40	32	32	32	55	55	-
H-12	M20	M20	M20	M20	M20	M24	M24	-
H-13	43	55	-	79	-	83	-	-
H-14	38	-	-	12.7	-	-	-	-
H-15	-	-	-	8	-	7	-	-
Corresponding	HC-15, HC-18	HC/HCH-21, HC/HCH-24, MH-221,224	HCH-32 [Serration]	HC-32 [Groove]	HC-32 [Serration]	HC-40[Groove] 50,55,63,70,80	HC-40[Serration] 50,55,63,70,80	-

T-NUT

Power Chuck T-Nuts



Application / Benefits

Power Chuck T-Nut

Fig. 1

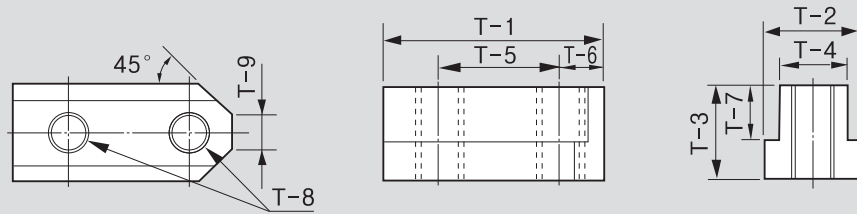

Fig. 2

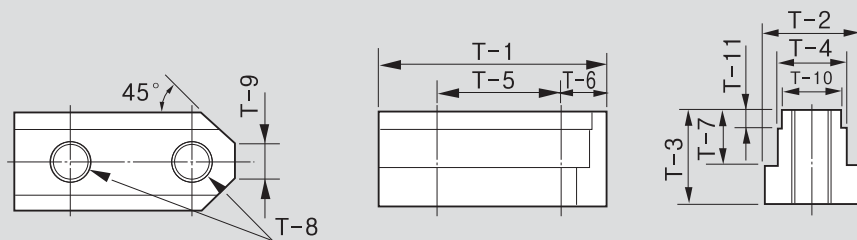
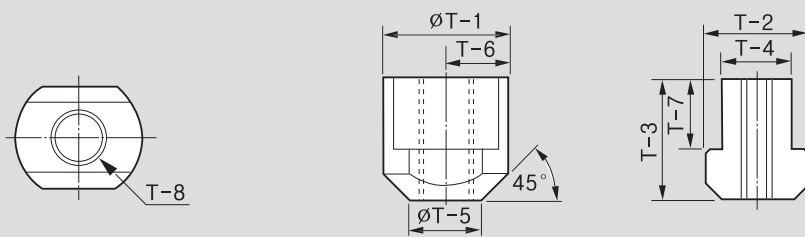

Fig. 3



※ See the product dimension Table on the right.

DIMENSIONS

	TN-HCH-04	TN-HS-04, TN-HS-05	TN-HC-04	TN-HC-05	TN-HS-06	TN-HCH, TN-HC-06	TN-HS-08	TN-HCH, TN-HC-08	TN-HS-10	TN-HCH, TN-HC-10
Fig.	1	1	1	1	1	1	1	1	1	1
T-1	24.5	26	28	32	36	36.5	46.5	48	51	55
T-2	11.5	15	15	15	17.5	17.5	20.5	20.5	22.5	22.5
T-3	13.5	15	18	18	18.5	22.5	20.5	25.5	21.5	25.5
T-4	8	10	10	10	12	12	14	14	16	16
T-5	15	14	14	19	20	20	25	25	30	30
T-6	4.5	6	7	6	8.25	7.5	10.5	11	11	11
T-7	9	9.5	12.5	12.5	11	15	12	16	13	16
T-8	M6	M8	M8	M8	M10	M10	M12	M12	M12	M12
T-9	5	5	5	6	8	6	12	8	11	8
T-10	-	-	-	-	-	-	-	-	-	-
T-11	-	-	-	-	-	-	-	-	-	-
Corresponding	HCH Type of 4" Chuck	HS Type of 4", 5" Chuck	HC Type of 4" Chuck	HC Type of 5" Chuck	HS/MH/UR Type of 6" Chuck	HCH/HC Type of 6" Chuck	HS/MH/UR Type of 8" Chuck	HCH/HC Type of 8" Chuck	HS/MH/UR Type of 10" Chuck	HCH/HC Type of 10" Chuck

	TN-HS-12	TN-HCH, TN-HC-12	TN-HCH-15, TN-HCH-18	TN-HC-15, TN-HC-18	TN-MH-218	TNX-HC-21, TNX-HC-24	TN-HCH-32	TN-HC-32	TN-HC-40
Fig.	1	1	2	1	2	3	3	3	3
T-1	55.5	55.5	80	80	80	46	35	37	42
T-2	29.5	26.5	33.5	35	33.5	37.5	35	37.5	42.5
T-3	27.75	33.5	45.5	49	45.5	45	39.5	47.5	49.5
T-4	21	18	24	25.5	24	25	25.5	25.5	30
T-5	30	30	43	43	50	26.5	25	-	-
T-6	12	11.5	17	17	17	23	-	-	-
T-7	16.25	20	29	20	29	26	20.5	28.5	30.5
T-8	M16	M14	M20	M20	M20	M20	M20	M20	M24
T-9	13	12	11	11	16	-	-	-	-
T-10	-	-	22	-	-	-	-	-	-
T-11	-	-	7.5	-	-	-	-	-	-
Corresponding	HS/MH Type of 12" Chuck	HCH/HC Type of 12" Chuck	HCH Type of 15", 18" Chuck	HC Type of 5", 18" Chuck	MH-218	HC/HCF-21,24 HCH/HCHF- 21,24(H), MH-221(H)	HCH-32	HC-32	HC-40

※ TNX-HC-21-24, TNX-HC-32 require two T-nuts per jaw.

※ TNX-HC-40 require three T-nuts per jaw.



Samchully Grease
Item No: SW-20

Important for maintenance and safe operation.

- Fortified with molybdenum disulfide (MoS₂)
- Maximum extreme-pressure protection
- Exceptional adhesion & cohesion characteristics
- Superior friction-reduction properties-protects against friction-related heat & wear
- Excellent resistance to water washout & spray off
- Reduces maintenance & downtime
- Reduces operating temperatures
- Extends equipment life.

Adaptor Plates

Power Chuck Adaptor Plates

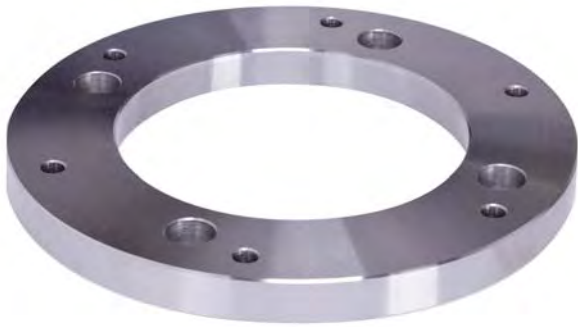

Application / Benefits
Power Chuck Adaptor Plates

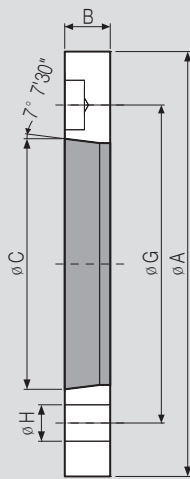

Fig. 1 : Direct Type

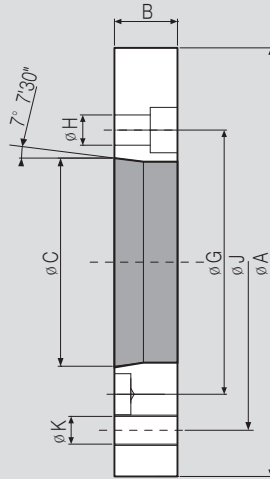

Fig. 2 : Indirect Type

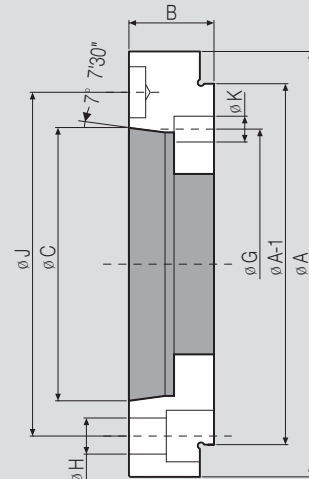

Fig. 3 : Plate Type

※ See the product dimension Table on the right.

DIMENSIONS

	Fig.	Spindle Nose	A	B	C	G	H	Corresponding
AP06A05	1	A2-5	140	15	82.563	104.78	12	HS/HSL/HCH/HC/HCL-06, MH-206, UR-175
APT06A05	1	A2-5	140	15	82.563	104.78	12	HST/HCT/HCLT-06, MHT-206
AP08A06	1	A2-6	170	17	106.375	133.35	13.5	HS/HSL/HCH/HC/HCL-08, MH-208, UR-210
APT08A06	1	A2-6	170	17	106.375	133.35	13.5	HST/HCT/HCLT-08, MHT-208
APF08A06	1	A2-6	170	17	106.375	133.35	13.5	HSF/HCF/HCLF-08, MHF-208
AP10/12A08	1	A2-8	220	18	139.719	171.45	18	HS/HSL/HCH/HC/HCL-10,12, MH-210, UR-250
APT10/12A08	1	A2-8	220	18	139.719	171.45	17	HST/HCT/HCLT-10,12
APF10/12A08	1	A2-8	220	18	139.719	171.45	18	HSF-10,12, HCF/HCLF-12
AP212A08	1	A2-8	300	22	139.719	235	21	MH-212, UR-315
AP212A11	1	A2-11	300	22	196.87	235	21	MH-212
AP15A11	1	A2-11	300	22	196.87	235	21	HCH-15, HC-15,18
APT15A11	1	A2-11	300	22	196.87	235	21	HCHT-15
APF15A11	1	A2-11	300	22	196.87	235	21	HCHF-15, HCF-15,18
AP18A11	1	A2-11	380	22	196.87	235	21	HCH-18
APF18A11	1	A2-11	380	22	196.87	235	21	HCHF-18
AP21/24A15	1	A2-15	380	27	285.775	330.2	24	HCH/HC-21,24, MH-221,224

	Fig.	Spindle Nose	A	B	C	G	H	J	K	Corresponding
AP08A05	2	A2-5	170	25	82.563	104.78	12	133.35	M12	HS/ HST/ HSF/ HSL/ HCH/ HC/ HCT/ HCF/ HCL/ HCLT/ HCLF-08, MH/ MHT/ MHF-208
AP10/12A06	2	A2-6	220	25	106.375	133.35	13.5	171.45	M16	HS/ HST/ HSF/ HSL/ HCH/ HC/ HCT/ HCL/ HCLT-10,12, MH-210, HCF/ HCLF-12
AP15A08	2	A2-8	300	33	139.719	171.45	18	235	M20	HCH/ HCHT/ HCHF-15, HC/HCF-15,18
AP218A15	2	A2-15	380	60	285.775	330.2	24	300	M20	MH-218
AP21/24A11	2	A2-11	380	27	196.87	235	21	330.2	M22	HCH/ HC-21,24, MH-221,224
AP21/24A11	2	A2-11	380	42	196.87	235	22	330.2	M22	HCH/ HCHF/ HC/ HCF-21,24, MH-221,224
AP21/24A11	2	A2-11	380	42	196.87	235	22	330.2	M24	HC/HCF-32, HCH/HCHF/HC-21N,24N
AP21/24A15	2	A2-15	380	42	285.775	330.2	24	330.2	M22	HCH/ HC-21,24, MH-221,224
AP32A15	2	A2-15	380	42	285.775	330.2	26	330.2	M24	HC-32
AP32/40A11	2	A2-11	520	50	196.87	235	22	463.6	M24	HCH-32, HC-40, HC-50
AP32/40A15	2	A2-15	520	42	285.775	330.2	26	463.6	M24	HCH-32, HC-40, HC-50

	Fig.	Spindle Nose	A	A-1	B	C	G	H	J	K	Corresponding
AP06A06	3	A2-6	165	140	33	106.375	133.35	14	104.78	M10	HS/ HSL/ HCH/ HC/ HCL-06, MH-206
AP08A08	3	A2-8	210	170	30	139.719	171.45	18	133.35	M12	HS/ HST/ HSF/ HSL/ HCH/ HC/ HCT/ HCF/ HCL/ HCLT/ HCLF-08, MH/ MHT/ MHF-208

QJC-Jaw Quick Jaw Change Chuck Jaws



Soft Top Jaws



Hard Top Jaws

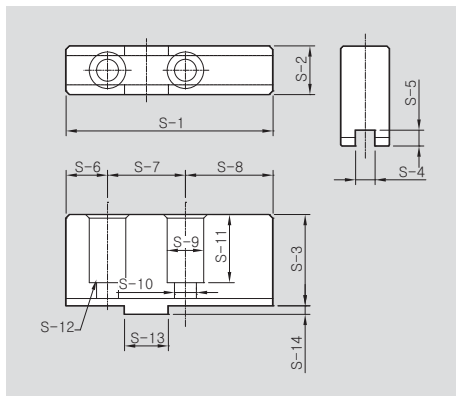

SOFT TOP JAWS DIMENSIONS

	QSB206	QSB208	QSB210	QSB215
S-1	85	105	125	145
S-2	20	22	30	35
S-3	37.5	40	50	50
S-4	8	10	12	12
S-5	6.5	8.5	8.5	8.5
S-6	17	25	25	31
S-7	32	40	40	54
S-8	36	40	60	60
S-9	15	15	20	20
S-10	9	9	14	14
S-11	28	31	39	34
S-12	M8x20	M8x20	M12x30	M12x40
S-13	18	20	20	26
S-14	3.5	5	5	5
Corresponding	QJC-206	QJC-208	QJC-210,QJC-212	QJC-215

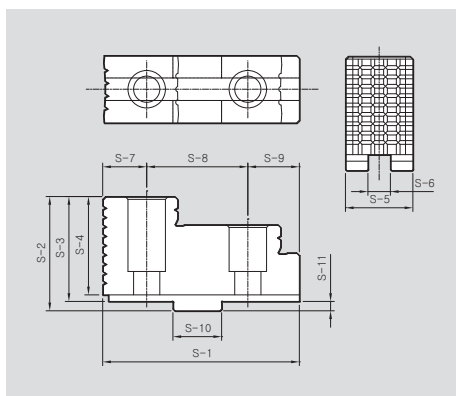

HARD TOP JAWS DIMENSIONS

	QHB206	QHB208	QHB210	QHB215
S-1	63	72	90	105
S-2	36	43	55	61
S-3	32.5	38	50	56
S-4	29.5	34.5	46.5	52.5
S-5	20	22	30	36
S-6	8	10	12	12
S-7	17	15	21	23.5
S-8	32	40	40	54
S-9	14	17	29	27.5
S-10	18	20	20	26
S-11	3.5	5	5	5
Corresponding	QJC-206	QJC-208	QJC-210,QJC-212	QJC-215



Base Jaws



Monoblok Soft Jaws



Monoblok Hard Jaws

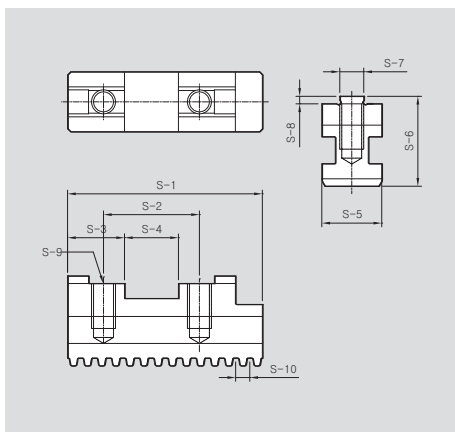

BASE JAWS DIMENSIONS

	QBJ206	QBJ208	QBJ210	QBJ212	QBJ215
S-1	65	85	104	115	125
S-2	32	40	40	40	54
S-3	19	23	26	26	30
S-4	18	20	20	20	26
S-5	20	22	26	32	32
S-6	30	32	40	45	45
S-7	8	10	12	12	12
S-8	2.5	2	3	3	3
S-9	M8	M8	M12	M12	M12
S-10	4.712	4.712	5.498	5.498	5.498
Corresponding	QJC-206	QJC-208	QJC-210	QJC-212	QJC-215

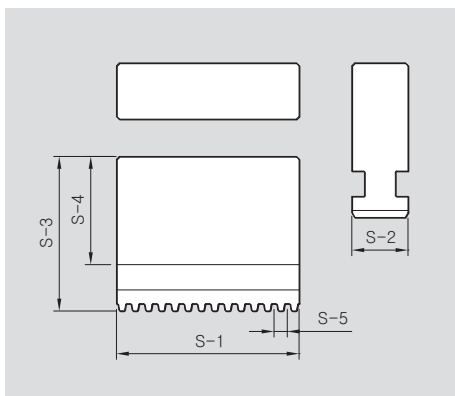

SOLID SOFT JAWS DIMENSIONS

	MQSB206	MQSB208	MQSB210	MQSB212	MQSB215
S-1	65	85	104	115	125
S-2	20	22	26	32	32
S-3	55	65	84	90	100
S-4	38.5	48	63	64	74
S-5	4.712	4.712	5.498	5.498	5.498
Corresponding	QJC-206	QJC-208	QJC-210	QJC-212	QJC-215

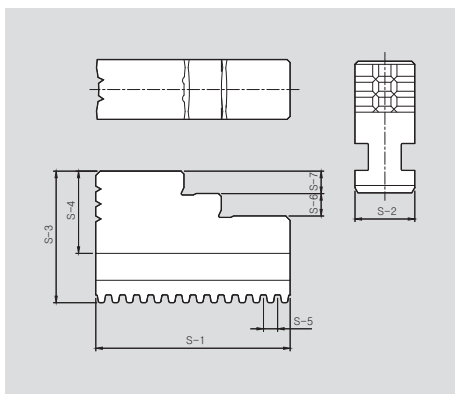

SOLID HARD JAWS DIMENSIONS

	MQHB206	MQHB208	MQHB210	MQHB212	MQHB215
S-1	65	85	104	115	125
S-2	20	22	26	32	32
S-3	55	65	84	90	100
S-4	38.5	48	63	64	74
S-5	4.712	4.712	5.498	5.498	5.498
S-6	7.5	10	14	14	45
S-7	7.5	10	14	14	15
Corresponding	QJC-206	QJC-208	QJC-210	QJC-212	QJC-215

TC, FTC-Jaw Scroll Chuck Jaws



TC / FTC Soft Jaws



TC / FTC Hard Jaws



TC / FTC Base Jaws

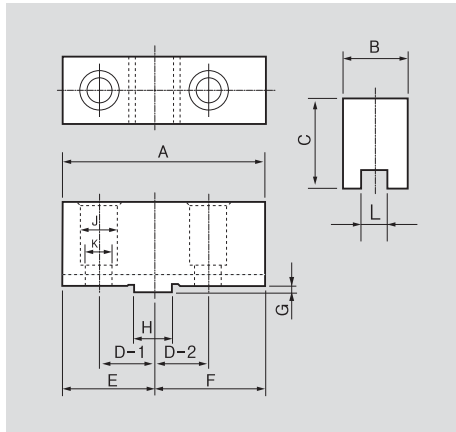

TC/FTC SOFT JAWS DIMENSIONS

	TC-190	TC-230	TC-273	TC-310	FTC-460	FTC-535	FTC-610
A	88	100	110	125	140	150	150
B	32	32	35	40	50	50	50
C	41	44	48.5	49.5	71.5	76.5	76.5
D-1	22.225	26.99	26.99	31.75	38.1	38.1	38.1
D-2	22.225	26.99	26.99	31.75	38.1	38.1	38.1
E	40	45	51	58	63.5	67.5	67.5
F	48	55	59	67	76.5	82.5	82.5
G	3	3	3	3	5.8	6	6
H	12.68	19.03	19.03	19.03	19.03	19.03	19.03
J	17	19	19	19	32	32	32
K	11	12.7	12.7	12.7	22	22	22
L	7.94	12.7	12.7	12.7	12.7	12.7	12.7
M	7	7	7	7	-	-	-

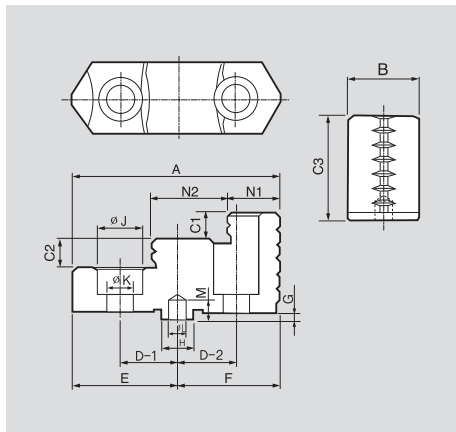

TC/FTC HARD JAWS DIMENSIONS

	TC-190	TC-230	TC-273	TC-310	FTC-450	FTC-535	FTC-610
A	80.5	90.5	103.5	115.5	130	130	130
B	28	32	35	40	50	50	50
C1	10	12	14	15	17	17	17
C2	10	12	14	15	17	17	17
C3	41	48	52	54	76.8	76.8	76.8
D1	22.225	26.99	26.99	31.75	38.1	38.1	38.1
D2	22.225	26.99	26.99	31.75	38.1	38.1	38.1
E	40.5	45.5	52	58	63.5	63.5	63.5
F	40	45	51.5	57.5	66.5	66.5	66.5
G	3	3	3	3	5.8	5.8	5.8
H	12.68	19.03	19.03	19.03	19.025	19.025	19.025
ΦJ	17	19	19	19	32	32	32
ΦK	11	13	13	13	22	22	22
ΦL	7.9	12.7	12.7	12.7	-	-	-
N1	21.5	23.5	31.5	30.5	52	52	52
N2	29	33	34	40	35	35	35

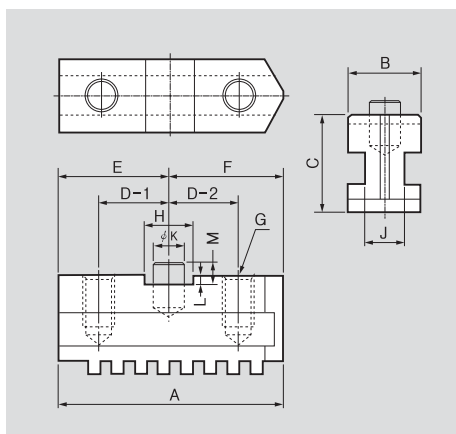

TC/FTC BASE JAWS DIMENSIONS

	TC-190	TC-230	TC-273	TC-310	FTC-460	FTC-535	FTC-610
A	75	87	98	111	165	177	205
B	28	28	28	32	45	50	50
C	34	38	40	42.5	54	57	60
D-1	22.225	26.99	26.99	31.75	38.1	38.1	38.1
D-2	22.225	26.99	26.99	31.75	38.1	38.1	38.1
E	35.5	42.5	47	54	-	-	-
F	39.5	44.5	51	57	66.5	66.5	66.5
G	2-M10	2-M12	2-M12	2-M12	4-M20	4-M20	5-M20
H	12.68	19.03	19.03	19.03	2-19.025	2-19.025	2-19.025
J	15	15	15	17.2	27	30	30
K	7.95	12.7	12.7	12.7	-	-	-
L	3.5	3.5	3.5	3.5	-	-	-
M	6.5	6.5	6.5	6.5	9.3	9.3	9.3

SC, IC-Jaw Scroll Chuck Jaws



SC Jaws(Internal)



SC Jaws(External)



IC Jaws

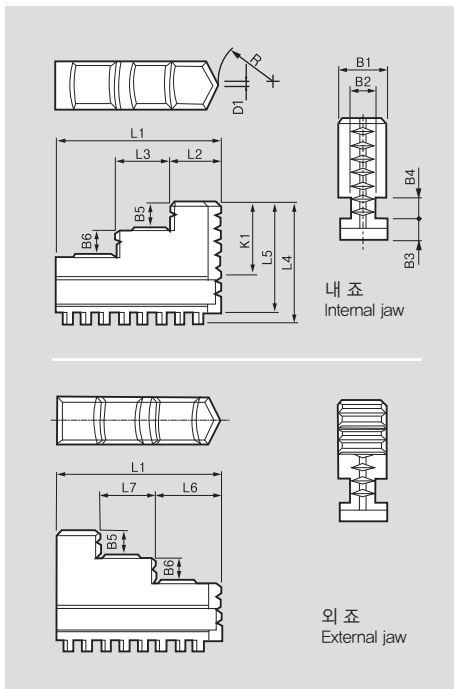

SC JAWS DIMENSIONS

	SC-85	SC-110	SC-130	SC-165	SC-190	SC-230	SC-273	SC-310	SC-355	SC-405
L1	35	42	50	65	75	85	98	110	133	133
L2	11	13	15	20	23	26	30	35	44	44
L3	10	13	15	22	25	28	33	35	42	42
L4	29	34.5	40	46.5	55.5	64.5	69.5	82.5	101	101
L5	26.5	31	36	42	50.5	59.5	64	76	94.5	94.5
L6	16	19	21	27	30	33	38	43	53	53
L7	10	13	15	22	25	28	33	35	42	42
B1	11	14	16	19	22	24	28	30	35	35
B2	5.7	7.5	7.2	9.2	11.2	13.2	15	15	19	19
B3	4.7	6.2	7.7	8.2	9.7	11.2	11.2	13.4	14	14
B4	6.55	6.55	8.2	8.13	9.74	11.38	11.38	16.12	16.2	16.2
B5	6	7	8	10	12	14	15	16	21	21
B6	6	4.3	7.4	10	12	14	15	16	22	22
K1	17.75	21.05	23.4	25.07	30.06	35.04	40.02	45.08	62.98	62.98
R	7.5	11	15	20	25	30	37	43	43	43
D1	1	1.5	1.5	2	2	3	3	4	4	4

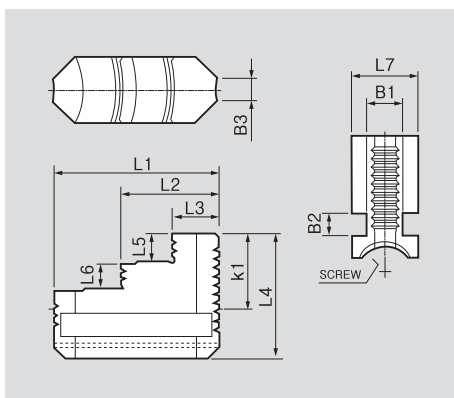

IC JAWS DIMENSIONS

	IC-08	IC-10	IC-12	IC-14	IC-16	IC-18	IC-20	IC-24	IC-28	IC-32
L1	75	90	100	110	120	130	140	160	160	200
L2	44	54	60	67	73.5	80	85	99	100	120
L3	21	26	28	31	33.5	37	40	46	47	55
L4	55.5	61.5	70.5	75.5	84	89	106	116.4	111	138
L5	12	14	16	18	20	22	24	28.2	28	30
L6	12	14	16	18	20	22	24	28.2	29	30
L7	30	30	35	35	40	40	45	50	50	60
B1	16	16	19	19	22.5	22.5	27.5	31	30	40
B2	10.3	10.3	11.5	11.5	11.5	11.5	16.4	16.4	15.3	20
B3	10	10	13.6	14.6	15	15	16	18	20	34
K1	30	35	40	45	50	55	60	70	70	89
Threads/inch	5/inch	5/inch	4/inch	4/inch	4/inch	4/inch	3.5/inch	3.5/inch	4/inch	6.0 mm

Accessories

Scroll Chuck Accessories



IC Screw Bar



IC Stopper

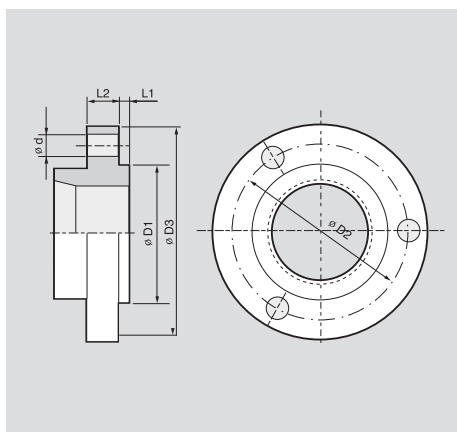

SC ADAPTOR DIMENSIONS (Reference)

		SC-85	SC-110	SC-130	SC-165	SC-190	SC-230	SC-273	SC-310	SC-355
ΦD1	base length	60	80	100	130	155	190	230	260	300
	tolerance	-0.021	-0.021	-0.025	-0.028	-0.028	-0.033	-0.033	-0.036	-0.036
ΦD2	base length	73	95	115	147	172	210	250	285	328
	tolerance	±0.2	±0.2	±0.2	±0.2	±0.2	±0.2	±0.2	±0.3	±0.3
ΦD3		88	115	135	170	195	235	275	310	355
L1		3	4	4	4.5	4.5	5.5	5.5	6.5	6.5
L2		10	12	12	15	18	20	20	22	26
Φd		6.6	9	11	11	13	13	13	13	13

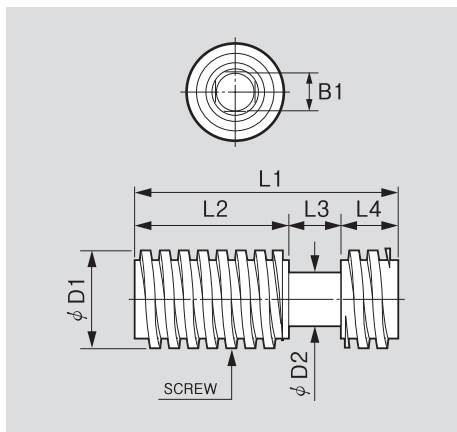

IC SCREW BAR DIMENSIONS

	IC-08	IC-10	IC-12	IC-14	IC-16	IC-18	IC-20	IC-24	IC-28	IC-32
L1	70	91.5	111	130	149	169	189	233	299	330
L2	41	58	73	85.5	108.5	123.5	137	162	193	216
L3	14	14	16	16	18	18	20	20	18	24
L4	15	19.5	22	28.5	22.5	27.5	32	51	68	90
ΦD1	26	26	30	30	34	34	35	38	38	44
ΦD2	14	14	16	16	18	18	19	20	22	28
B1	10	10	12	12	14	14	14	14	14	19
Thread / inch	5/inch	5/inch	4/inch	4/inch	4/inch	4/inch	4/inch	4/inch	4/inch	4.5/inch

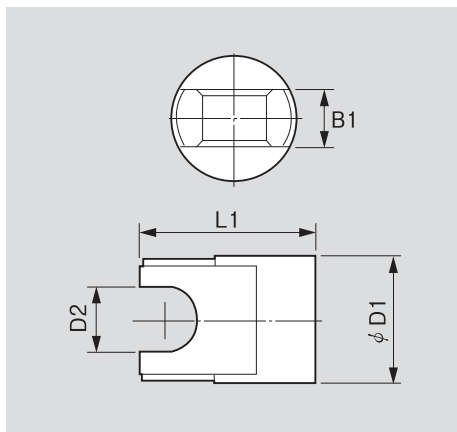

IC STOPPER DIMENSIONS

	IC-08	IC-10	IC-12	IC-14	IC-16	IC-18	IC-20	IC-24	IC-28	IC-32
L1	42	45	51	49	55	60	53	59	57.5	59
ΦD1	26	26	30	30	34	34	35	38	38	44
ΦD2	14.5	14.5	16.5	16.5	18.5	18.5	19.5	20.5	23	27.5
B1	14	14	16	16	18	18	20	20	18	24



Scroll Chuck Handles

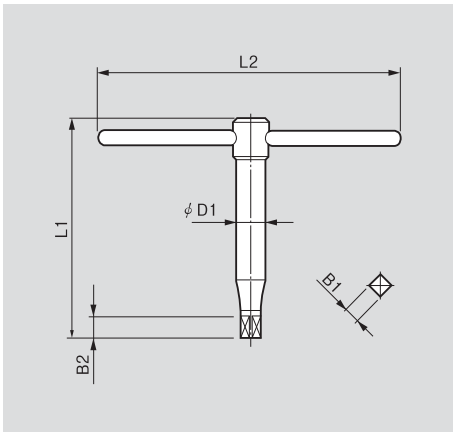

SC, FTC, SL, IC HANDLE DIMENSIONS

	SC-85	SC-110	SC-130	SC-165	SC-190	SC-230	SC-273	SC-310	SC-355	SC-405
L1	65	70	75	120	160	160	160	200	200	170
L2	110	140	170	210	240	290	330	390	390	450
B1	7	8	8	10	11	12	12	14	14	15
B2	10	11	11	13	14	15	15	18	18	20
ØD1	15	17	20	20	20	22	22	26	26	26

	FTC-460	FTC-535	FTC-610	SL-08	SL-10	SL-12
L1	205	230	230	200	240	280
L2	500	500	500	240	270	320
B1	17	6*-22	6*-22	11	12	14
B2	20	26	26	16	16	18
ØD1	25	30	30	20	22	26

	IC-08	IC-10	IC-12	IC-14	IC-16	IC-18	IC-20	IC-24	IC-28	IC-32
L1	130	150	170	170	220	220	220	230	300	300
L2	200	250	300	350	400	400	450	500	500	500
B1	10	10	12	12	14	14	14	14	14	19
B2	14	14	17	17	19	19	20	20	20	20
ØD1	15	18	19	19	22	22	22	25	28	35

* 6* = Hexagon

Sales Network

America & Canada

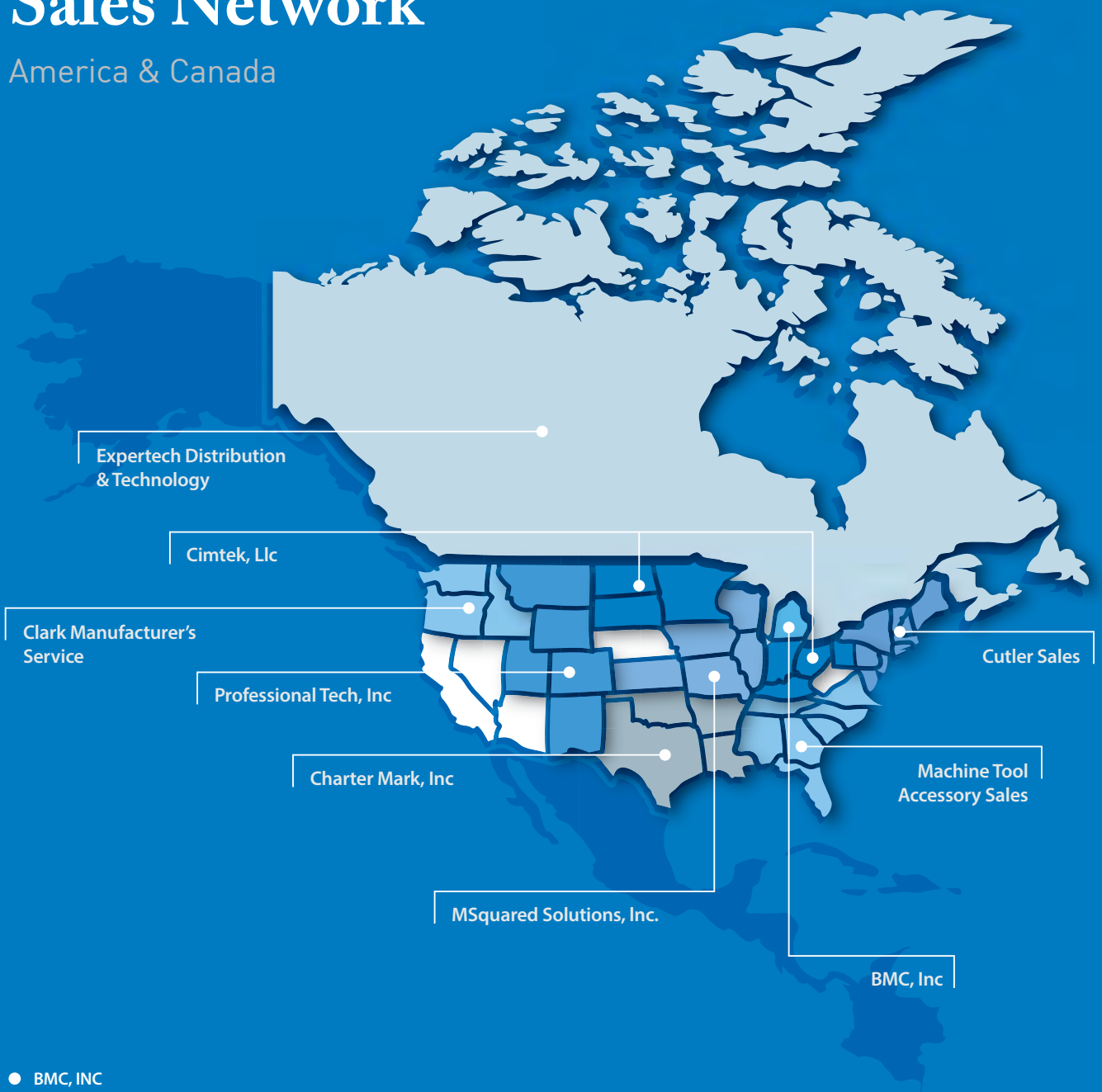

● **BMC, INC**
(440) 725-2182
j.bluhm@samchullyworkholding.com

● **CHARTERMARK, INC**
(281) 821-8288
k.paull@samchullyworkholding.com

● **CIMTEK, LLC**
(262) 219-9126
s.shippell@samchullyworkholding.com

● **CLARK MANUFACTURER'S SERVICE**
(206) 393-2653
m.clark@samchullyworkholding.com

● **CUTLER SALES**
(631) 277-4930
b.cutler@samchullyworkholding.com

● **EXPERTECH DISTRIBUTION & TECHNOLOGY**
(647) 960-4478
p.seessle@samchullyworkholding.com

● **MACHINE TOOL ACCESSORY SALES**
(770) 331-7990
r.gesuelle@samchullyworkholding.com

● **MSQUARED SOLUTIONS**
(847) 721-3256
m.murray@samchullyworkholding.com

● **PROFESSIONAL TECH, INC**
(720) 837-3232
c.hand@samchullyworkholding.com



www.Samchully.com

Samchully Machinery(HEAD OFFICE)

99, Namdong-daero, Namdong-gu, Incheon, Korea TEL. +82-32-822-4811 FAX. +82-32-822-4377

Samchully Workholding(USA OFFICE)

20472 Crescent Bay Drive Lake Forest, CA 92630 TEL. +1 (949) 727-3001
FAX : +1 (949) 727-7070 TOLL FREE : +1 (877) 750-GRIP(4747)



E2016-A1