



■ Inhalt:

- | Werkzeughalter DIN 69880
- | Stangengreifer
- | Kurzbohrfutter
- | Mitlaufende Zentrierspitzen
- | Pendelhalter
- | Räumwerkzeughalter
- | Werkstückanschläge
- | Prüfdorne
- | Einrichtehalter
- | Reduzierbuchsen, Kugelspritzdüsen, O-Ringe
- | Schutzstopfen

■ Content:

- | Tool holders DIN 69880
- | Bar pullers
- | Universal drill chucks
- | Revolving tailstock centres
- | Floating chucks
- | Broach tool holders
- | Work piece stops
- | Test arbors
- | Setting holders
- | Reduction sleeves, ball spray nozzles, O-rings
- | Protective plugs

VDI-Halter

VDI-Tool holders

Einsatz von Axial-Werkzeughaltern bei linker Spindeldrehrichtung

Application of axial tool holders with left-hand spindle rotation

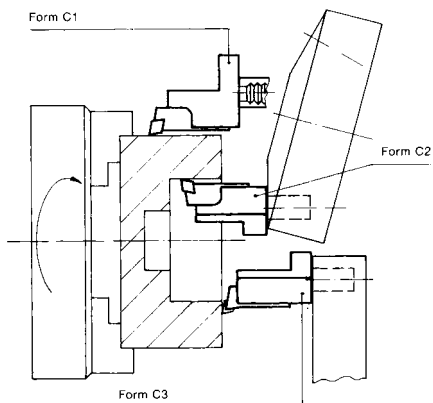

Einsatz von Radial-Werkzeughaltern bei linker Spindeldrehrichtung

Application of radial tool holders with left-hand spindle rotation

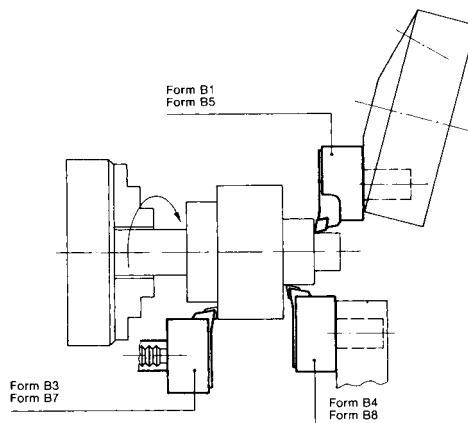

Einsatz von Axial-Werkzeughaltern bei rechter Spindeldrehrichtung

Application of axial tool holders with right-hand spindle rotation

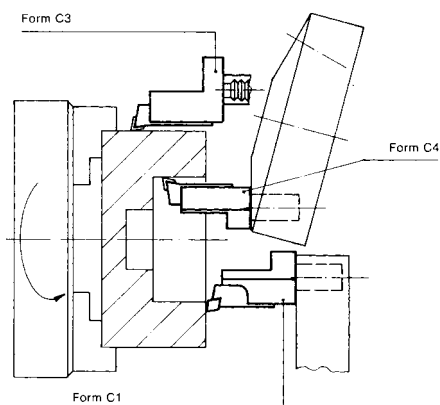

Einsatz von Radial-Werkzeughaltern bei rechter Spindeldrehrichtung

Application of radial tool holders with right-hand spindle rotation

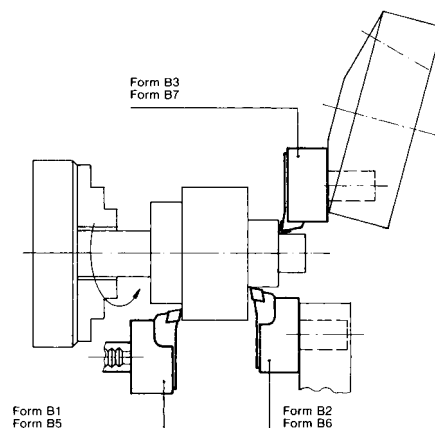

Typ A1, Werkzeughalter-Rohling, rechteckig*

Type A1, rectangular soft blank*

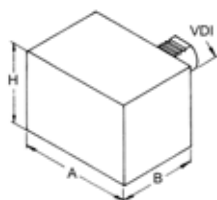

VDI	A mm	H mm	B mm	Art.-Nr. / Order no.
16	78	44	44	● 47-A1-16-44
20	100	60	65	● 47-A1-20-65
25	100	60	75	● 47-A1-25-75
30	130	76	85	● 47-A1-30-85
40	151	96	100	● 47-A1-40-100
40	60	96	220	✘ 47-A1-40-220
50	160	120	125	● 47-A1-50-125
60	165	125	160	● 47-A1-60-160

* Material 42 CRMo 4

VDI-Halter

VDI-Tool holders

Typ A2, Werkzeughalter-Rohling, rund*

Type A2, round soft blank*

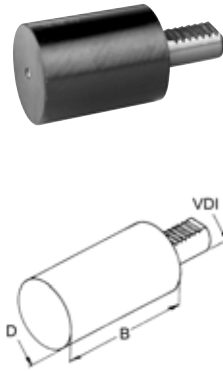

VDI	D mm	B mm	Art.-Nr. / Order no.
16	40	60	● 47-A2-16-60
20	50	70	● 47-A2-20-70
25	58	80	● 47-A2-25-80
25	58	200	● 47-A2-25-200
30	68	100	● 47-A2-30-100
30	68	240	● 47-A2-30-240
40	83	120	● 47-A2-40-120
40	83	320	● 47-A2-40-320
50	98	135	● 47-A2-50-135
50	98	400	● 47-A2-50-400
60	123	150	● 47-A2-60-150
60	123	480	● 47-A2-60-480

* Material: 42 CrMo 4

Typ B1, Radial-Werkzeughalter, rechts, kurz

Type B1, radial tool holder, right-hand, short

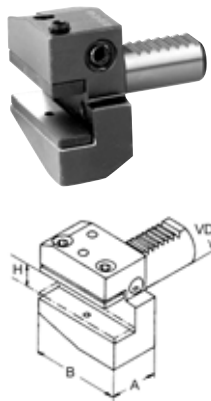

VDI	H mm	A mm	B mm	Art.-Nr. / Order no.
16	10/12	24	42	● 47-B1-16-12
20	12/16	30	55	● 47-B1-20-16
25	12/16	30	55	● 47-B1-25-16
30	16/20	40	70	● 47-B1-30-20
40	20/25	44	85	● 47-B1-40-25
50	25/32	55	100	● 47-B1-50-32
60	25/32	60	125	● 47-B1-60-32

Typ B2, Radial-Werkzeughalter, links, kurz

Type B2, radial tool holder, left-hand, short

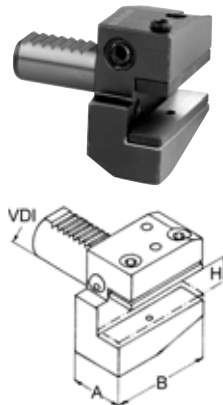

VDI	H mm	A mm	B mm	Art.-Nr. / Order no.
16	10/12	24	42	● 47-B2-16-12
20	12/16	30	55	● 47-B2-20-16
25	12/16	30	55	● 47-B2-25-16
30	16/20	40	70	● 47-B2-30-20
40	20/25	44	85	● 47-B2-40-25
50	25/32	55	100	● 47-B2-50-32
60	25/32	60	125	● 47-B2-60-32

Typ B3, Radial-Werkzeughalter, überkopf, rechts, kurz

Type B3, radial tool holder, inverted, right-hand, short

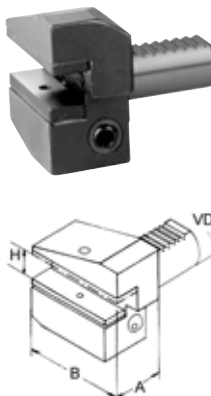

VDI	H mm	A mm	B mm	Art.-Nr. / Order no.
16	10/12	24	42	● 47-B3-16-12
20	12/16	30	55	● 47-B3-20-16
25	12/16	30	55	● 47-B3-25-16
30	16/20	40	70	● 47-B3-30-20
40	20/25	44	85	● 47-B3-40-25
50	25/32	55	100	● 47-B3-50-32
60	25/32	60	125	● 47-B3-60-32

VDI-Halter

VDI-Tool holders

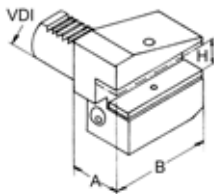

Typ B4, Radial-Werkzeughalter, überkopf, links, kurz

Type B4, radial tool holder, inverted, left-hand, short

VDI	H mm	A mm	B mm	Art.-Nr. / Order no.
16	10/12	24	42	● 47-B4-16-12
20	12/16	30	55	● 47-B4-20-16
25	12/16	30	55	● 47-B4-25-16
30	16/20	40	70	● 47-B4-30-20
40	20/25	44	85	● 47-B4-40-25
50	25/32	55	100	● 47-B4-50-32
60	25/32	60	125	● 47-B4-60-32

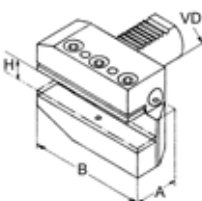

Typ B5, Radial-Werkzeughalter, rechts, lang

Type B5, radial tool holder, right-hand, long

VDI	H mm	A mm	B mm	Art.-Nr. / Order no.
16	10/12	24	58	● 47-B5-16-12
20	12/16	30	75	● 47-B5-20-16
25	12/16	30	75	● 47-B5-25-16
30	16/20	40	100	● 47-B5-30-20
40	20/25	44	118	● 47-B5-40-25
50	25/32	55	130	● 47-B5-50-32
60	25/32	60	145	● 47-B5-60-32

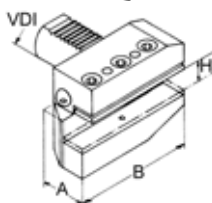

Typ B6, Radial-Werkzeughalter, links, lang

Type B6, radial tool holder, left-hand, long

VDI	H mm	A mm	B mm	Art.-Nr. / Order no.
16	10/12	24	58	● 47-B6-16-12
20	12/16	30	75	● 47-B6-20-16
25	12/16	30	75	● 47-B6-25-16
30	16/20	40	100	● 47-B6-30-20
40	20/25	44	118	● 47-B6-40-25
50	25/32	55	130	● 47-B6-50-32
60	25/32	60	145	● 47-B6-60-32

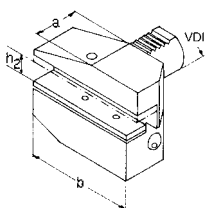

Typ B7, Radial-Werkzeughalter, überkopf, rechts, lang

Type B7, radial tool holder, inverted, right-hand, long

VDI	H mm	A mm	B mm	Art.-Nr. / Order no.
16	10/12	24	58	● 47-B7-16-12
20	12/16	30	75	● 47-B7-20-16
25	12/16	30	75	● 47-B7-25-16
30	16/20	40	100	● 47-B7-30-20
40	20/25	44	118	● 47-B7-40-25
50	25/32	55	130	● 47-B7-50-32
60	25/32	60	145	● 47-B7-60-32

- Lagerstandard / in stock
- ▶ innerhalb weniger Tage / within a few days
- auf Anfrage / on request
- * auslaufende Größe / as stock lasts



VDI-Halter

VDI-Tool holders

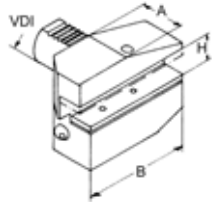

Typ B8, Radial-Werkzeughalter, überkopf, links, lang

Type B8, radial tool holder, inverted, left-hand, long

VDI	H mm	A mm	B mm	Art.-Nr. / Order no.
16	10/12	24	58	47-B8-16-12
20	12/16	30	75	47-B8-20-16
25	12/16	30	75	47-B8-25-16
30	16/20	40	100	47-B8-30-20
40	20/25	44	118	47-B8-40-25
50	25/32	55	130	47-B8-50-32
60	25/32	60	145	47-B8-60-32

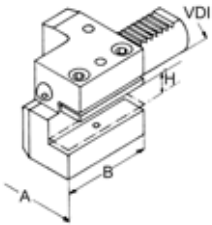

Typ C1, Axial-Werkzeughalter, rechts

Type C1, axial tool holder, right-hand

VDI	H mm	A mm	B mm	Art.-Nr. / Order no.
16	10/12	43	44	47-C1-16-12
20	12/16	52	50	47-C1-20-16
25	12/16	58	55	47-C1-25-16
30	16/20	76	70	47-C1-30-20
40	20/25	85	85	47-C1-40-25
50	25/32	100	100	47-C1-50-32
60	25/32	125	125	47-C1-60-32

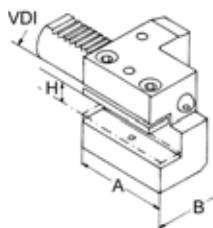

Typ C2, Axial-Werkzeughalter, links

Type C2, axial tool holder, left-hand

VDI	H mm	A mm	B mm	Art.-Nr. / Order no.
16	10/12	43	44	47-C2-16-12
20	12/16	52	50	47-C2-20-16
25	12/16	58	55	47-C2-25-16
30	16/20	76	70	47-C2-30-20
40	20/25	85	85	47-C2-40-25
50	25/32	100	100	47-C2-50-32
60	25/32	125	125	47-C2-60-32

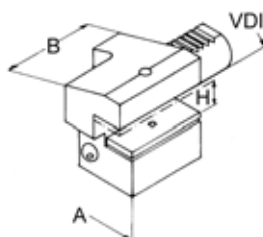

Typ C3, Axial-Werkzeughalter, überkopf, rechts

Type C3, axial tool holder, inverted, right-hand

VDI	H mm	A mm	B mm	Art.-Nr. / Order no.
16	10/12	43	44	47-C3-16-12
20	12/16	52	50	47-C3-20-16
25	12/16	58	55	47-C3-25-16
30	16/20	76	70	47-C3-30-20
40	20/25	85	85	47-C3-40-25
50	25/32	100	100	47-C3-50-32
60	25/32	125	125	47-C3-60-32



VDI-Halter

VDI-Tool holders

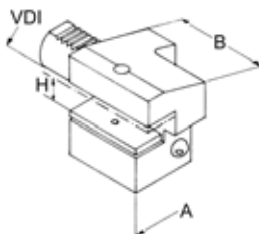

Typ C4, Axial-Werkzeughalter, überkopf, links

Type C4, axial tool holder, inverted, left-hand

VDI	H mm	A mm	B mm	Art.-Nr. / Order no.
16	10/12	43	44	● 47-C4-16-12
20	12/16	52	50	● 47-C4-20-16
25	12/16	58	55	● 47-C4-25-16
30	16/20	76	70	● 47-C4-30-20
40	20/25	85	85	● 47-C4-40-25
50	25/32	100	100	● 47-C4-50-32
60	25/32	125	125	● 47-C4-60-32



Typ D1, Vierkant-Mehrfach-Aufnahme

Type D1, multiple square tool holder

VDI	H mm	A mm	B mm	Art.-Nr. / Order no.
25	12/16	66	48	● 47-D1-25-16
30	16/20	76	60	● 47-D1-30-20
40	20/25	90	72	● 47-D1-40-25
50	25/32	105	85	● 47-D1-50-32



Typ D2, Vierkant-Mehrfach-Aufnahme, überkopf

Type D2, multiple square tool holder, inverted

VDI	H mm	A mm	B mm	Art.-Nr. / Order no.
25	12/16	66	48	● 47-D2-25-16
30	16/20	76	60	● 47-D2-30-20
40	20/25	90	72	● 47-D2-40-25
50	25/32	105	85	● 47-D2-50-32

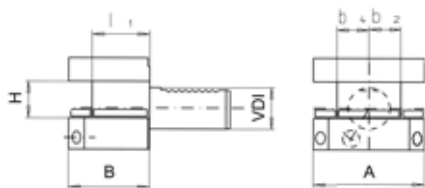

Abstechhalter, rechts

Parting off tool holder, right-hand

VDI	H mm	A mm	B mm	L mm	Art.-Nr. / Order no.
30	26	71	70	50	● 47-AR-30-26
40	26	84,5	85	50	● 47-AR-40-26
40	32	84,5	85	50	● 47-AR-40-32
50	32	88	100	50	● 47-AR-50-32
60	32	103	125	50	○ 47-AR-60-32

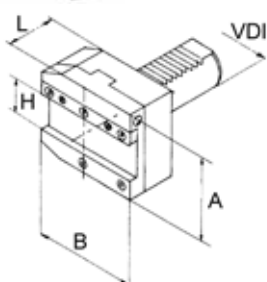

- Lagerstandard / in stock
- ▶ innerhalb weniger Tage / within a few days
- auf Anfrage / on request
- * auslaufende Größe / as stock lasts



VDI-Halter

VDI-Tool holders

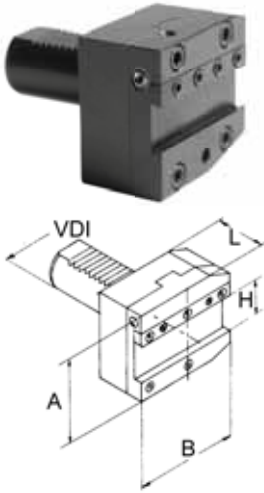

Abstechhalter, links

Parting off tool holder, left-hand

VDI	H mm	A mm	B mm	L mm	Art.-Nr. / Order no.
30	26	71	70	50	● 47-AL-30-26
40	26	84,5	85	50	● 47-AL-40-26
40	32	84,5	85	50	● 47-AL-40-32
50	26	88	100	50	● 47-AL-50-26
50	32	88	100	50	● 47-AL-50-32
60	32	103	125	50	○ 47-AL-60-32

Typ E1, Wendepplatten-Bohrerhalter, IK

Type E1, U-drill holder, IC

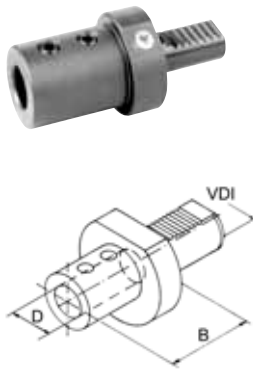

VDI	D mm	B mm	Art.-Nr. / Order no.
20	16	66	● 47-E1-20-16
20	20	67	● 47-E1-20-20
20	25	71	● 47-E1-20-25
25	20	67	● 47-E1-25-20
25	25	71	● 47-E1-25-25
30	10	66	● 47-E1-30-10
30	12	66	● 47-E1-30-12
30	16	66	● 47-E1-30-16
30	20	67	● 47-E1-30-20
30	25	71	● 47-E1-30-25
30	32	75	● 47-E1-30-32
30	40	90	● 47-E1-30-40
40	10	66	● 47-E1-40-10
40	12	66	● 47-E1-40-12
40	14	66	● 47-E1-40-14
40	16	66	● 47-E1-40-16
40	20	67	● 47-E1-40-20
40	25	75	● 47-E1-40-25
40	32	75	● 47-E1-40-32
40	40	90	● 47-E1-40-40
40	50	100	● 47-E1-40-50
50	20	67	● 47-E1-50-20
50	25	80	● 47-E1-50-25
50	32	80	● 47-E1-50-32
50	40	90	● 47-E1-50-40
50	50	100	● 47-E1-50-50
60	25	80	● 47-E1-60-25
60	32	80	● 47-E1-60-32
60	40	90	● 47-E1-60-40
60	50	100	● 47-E1-60-50

Beliebige Innendurchmesser, Zwischengrößen, Zollmaße etc. lieferbar auf Anfrage
Other internal diameters, intermediary bores, inch bores etc. available upon request



VDI-Halter

VDI-Tool holders

Typ E2, Bohrstangenhalter, IK/EK Type E2, boring bar holder, IC/EC

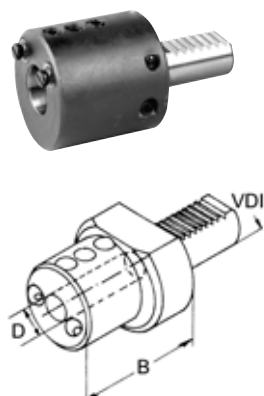

VDI	D mm	B mm	Art.-Nr. / Order no.
16	6	44	● 47-E2-16-06
16	8	44	● 47-E2-16-08
16	10	44	● 47-E2-16-10
16	12	44	● 47-E2-16-12
16	16	44	● 47-E2-16-16
20	8	50	● 47-E2-20-08
20	10	50	● 47-E2-20-10
20	12	50	● 47-E2-20-12
20	16	50	● 47-E2-20-16
20	20	50	● 47-E2-20-20
20	25	60	● 47-E2-20-25
25	8	50	○ 47-E2-25-08
25	10	50	○ 47-E2-25-10
25	12	50	○ 47-E2-25-12
25	16	50	● 47-E2-25-16
25	20	50	● 47-E2-25-20
25	25	60	● 47-E2-25-25
30	6	60	● 47-E2-30-06
30	8	60	● 47-E2-30-08
30	10	60	● 47-E2-30-10
30	12	60	● 47-E2-30-12
30	16	60	● 47-E2-30-16
30	20	60	● 47-E2-30-20
30	25	60	● 47-E2-30-25
30	32	75	● 47-E2-30-32
40	6	75	● 47-E2-40-06
40	8	75	● 47-E2-40-08
40	10	75	● 47-E2-40-10
40	12	75	● 47-E2-40-12
40	16	75	● 47-E2-40-16
40	20	75	● 47-E2-40-20
40	25	75	● 47-E2-40-25
40	32	75	● 47-E2-40-32
40	40	90	● 47-E2-40-40
40	50	90	● 47-E2-40-50
50	10	75	● 47-E2-50-10
50	12	90	● 47-E2-50-12
50	16	90	● 47-E2-50-16
50	20	90	● 47-E2-50-20
50	25	90	● 47-E2-50-25
50	32	90	● 47-E2-50-32
50	40	90	● 47-E2-50-40
50	50	100	● 47-E2-50-50
60	12	90	● 47-E2-60-12
60	16	90	● 47-E2-60-16
60	20	90	● 47-E2-60-20
60	25	90	● 47-E2-60-25
60	32	90	● 47-E2-60-32
60	40	90	● 47-E2-60-40
60	50	100	● 47-E2-60-50

**Beliebige Innendurchmesser, Zwischengrößen, Zollmaße etc.
lieferbar auf Anfrage**
**Other internal diameters, intermediary bores, inch bores etc.
available upon request**

- Lagerstandard / in stock
- ▶ innerhalb weniger Tage / within a few days
- auf Anfrage / on request
- * auslaufende Größe / as stock lasts



VDI-Halter

VDI-Tool holders



Typ E3, Spannzangenfutter OZ, für Spannzangen DIN 6388

Type E3, collet chucks OZ, for collets DIN 6388

VDI	OZ	D mm	Spannbereich / Clamping range	B mm	Art.-Nr. / Order no.
16	415 E	40	2-16	65	47-E3-16-16
20	415 E	50	2-16	57	47-E3-20-16
20	4541 E	50	4-20	62	47-E3-20-20
25	415 E	58	2-16	57	47-E3-25-16
30	462 E	68	2-25	75	47-E3-30-25
40	462 E	83	2-25	75	47-E3-40-25
40	467 E	83	4-32	90	47-E3-40-32
50	462 E	98	2-25	75	47-E3-50-25
50	467 E	98	4-32	90	47-E3-50-32
60	467 E	123	4-32	90	47-E3-60-32

Typ E4, Spannzangenfutter ER, für Spannzangen DIN 6499

Type E4, collet chucks ER, for collets DIN 6499



VDI	ER	D mm	Spannbereich / Clamping range	B mm	Art.-Nr. / Order no.
16	ER 16	40	1-10	40	47-E4-16-16
16	ER 20	40	1-13	44	47-E4-16-20
20	ER 16	50	1-10	40	47-E4-20-16
20	ER 20	50	1-13	44	47-E4-20-20
20	ER 25	50	1-16	54	47-E4-20-25
20	ER 32	50	2-20	40	47-E4-20-32
25	ER 25	58	1-16	57	47-E4-25-25
25	ER 32	58	2-20	62	47-E4-25-32
30	ER 25	68	1-16	53	47-E4-30-25
30	ER 32	68	2-20	62	47-E4-30-32
30	ER 40	68	2-25	53	47-E4-30-40
40	ER 25	83	1-16	53	47-E4-40-25
40	ER 32	83	2-20	84	47-E4-40-32
40	ER 40	83	2-25	75	47-E4-40-40
50	ER 32	98	2-20	84	47-E4-50-32
50	ER 40	98	2-25	90	47-E4-50-40
60	ER 40	123	2-25	75	47-E4-60-40

Typ E2S, Werkzeughalter geschlitzt, schwingungsarm

Type E2S, toolholder slotted, reduced vibration

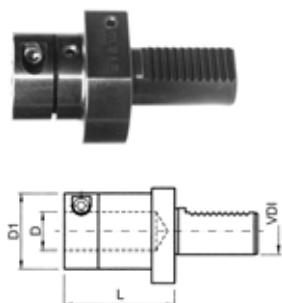

VDI	D mm	D1 mm	L mm	Art.-Nr. / Order no.
30	6	30	57	47-E2S-30-06
30	8	30	57	47-E2S-30-08
30	10	36	57	47-E2S-30-10
30	12	36	57	47-E2S-30-12
30	16	40	57	47-E2S-30-16
30	20	44	57	47-E2S-30-20
30	25	49	72	47-E2S-30-25
30	32	56	72	47-E2S-30-32
40	10	36	62	47-E2S-40-10
40	12	36	62	47-E2S-40-12
40	16	40	62	47-E2S-40-16
40	20	44	62	47-E2S-40-20
40	25	49	77	47-E2S-40-25
40	32	56	77	47-E2S-40-32
40	40	64	77	47-E2S-40-40



VDI-Halter

VDI-Tool holders

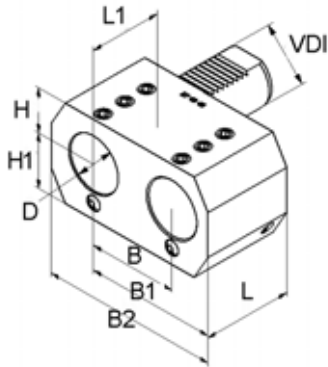

Typ E7, Doppel-Bohrstangenhalter

Typ E7, Boring bar holders with 2 bores

VDI	D mm	H mm	H1 mm	L mm	L1 mm	B mm	B1 mm	B2 mm	Art.-Nr. / Order no.
20	16	25	25	45	42	32	51	76	● 47-E7-20-16
20	20	25	25	45	42	32	51	76	● 47-E7-20-20
30	25	28	32	56	52	45	65	95	● 47-E7-30-25
40	32	32,5	40	66	60	50	75	115	● 47-E7-40-32
50	32	32,5	47,5	60	60	50	75	115	● 47-E7-50-32
50	40	42	46	66	60	68	103	145	● 47-E7-50-40
50	50	35	49	90	80	68	103	152	● 47-E7-50-50

Typ E8, Doppel-Bohrstangenhalter

Typ E8, Boring bar holders with 2 bores

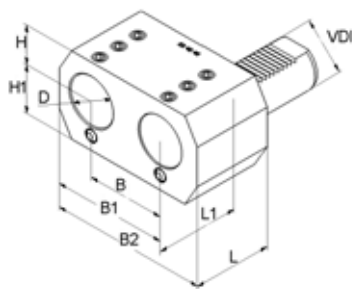

VDI	D mm	H mm	H1 mm	L mm	L1 mm	B mm	B1 mm	B2 mm	Art.-Nr. / Order no.
20	16	25	25	45	42	32	51	76	● 47-E8-20-16
20	20	25	25	45	42	32	51	76	● 47-E8-20-20
30	25	28	32	56	52	45	65	95	● 47-E8-30-25
40	32	32,5	40	66	60	50	75	115	● 47-E8-40-32
50	32	32,5	47,5	60	60	50	75	115	● 47-E8-50-32
50	50	35	49	90	80	68	103	152	○ 47-E8-50-50



VDI-Halter

VDI-Tool holders

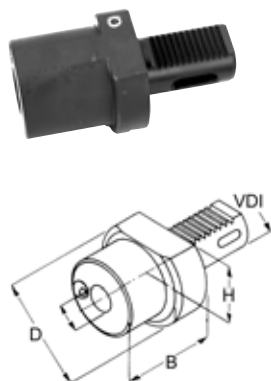

Typ F, Morsekegelaufnahme

Type F, Morse taper holder

VDI	MK / MT	H mm	D mm	B mm	Art.-Nr. / Order no.
20	1	23	50	22	● 47-F20-1
20	2	23	50	61	● 47-F20-2
25	1	25	58	22	● 47-F25-1
25	2	25	58	46	● 47-F25-2
30	1	28	68	27	● 47-F30-1
30	2	28	68	36	● 47-F30-2
30	3	28	68	66	● 47-F30-3
40	1	32,5	83	36	● 47-F40-1
40	2	32,5	83	36	● 47-F40-2
40	3	32,5	83	50	● 47-F40-3
40	4	32,5	83	80	● 47-F40-4
50	2	35	98	36	● 47-F50-2
50	3	35	98	45	● 47-F50-3
50	4	35	98	55	● 47-F50-4
50	5	35	98	68	● 47-F50-5
60	3	42,5	123	36	● 47-F60-3
60	4	42,5	123	50	● 47-F60-4
60	5	42,5	123	81	● 47-F60-5

Stangengreifer Bar pullers

Stangengreifer, Typ SGF Bar pullers, type SGF

- für zwei Spannbereiche
- mit Wendebacken

- for two clamping ranges
- with reversible clamping jaws

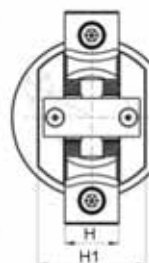
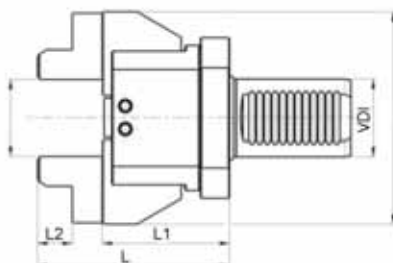

VDI	Spannbereich / Clamp.range	H mm	H1 mm	L mm	L1 mm	L2 mm	B mm	Art.-Nr. / Order no.
Zyl. / cyl. 32	6-110	28	56	100	66	18	110	47-SGF32Z
20	6-110	28	56	100	66	18	110	47-SGF20
30	6-110	28	56	100	66	18	110	47-SGF30
40	6-110	28	56	100	66	18	110	47-SGF40
50	6-110	28	56	100	66	18	110	47-SGF50

Stangengreifer, Typ SG25 Bar pullers, type SG25

- zylindrische Aufnahme D25 mit Spannfläche
- mit diamantbeschichteten Rollen für sicheren Halt, minimiert das Risiko einer Beschädigung des Rohmaterials
- stufenlose Einstellung auf jeden Durchmesser mit Hilfe der angebrachten Skala
- großer Spannbereich, verstellbar 1-70 mm, schnelle Verstellung des neuen Spannbereichs
- kompaktes Aluminium-Leichtgehäuse, blau eloxiert
- Lieferumfang: Stangengreifer inkl. 1 Paar Spannbacken mit diamantbeschichteten Rollen, 1 Paar feste Standardbacken, Bedienschlüssel

- cylindrical mounting D25 with clamping flat
- with diamond-coated rollers for an excellent grip, minimizing the damage risk for the clamped material
- any diameter is infinitely adjustable by means of a scale
- large clamping range from 1-70 mm, fast resetting of clamping range
- light-weight aluminium body, blue anodized
- scope of delivery: bar puller including 1 pair of jaws with diamond-coated rollers, 1 pair of fixed standard jaws, setting tools

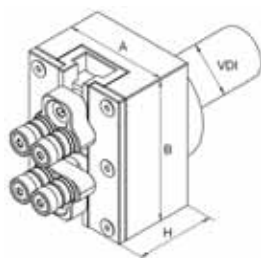

VDI	Spannbereich / Clamping range	A mm	B mm	H mm	Art.-Nr. / Order no.
25	1-70	55	75	42	47-SG25-70

- Lagerstandard / in stock
- ▶ innerhalb weniger Tage / within a few days
- auf Anfrage / on request
- * auslaufende Größe / as stock lasts

Kurzbohrfutter VDI

Universal drill chucks VDI

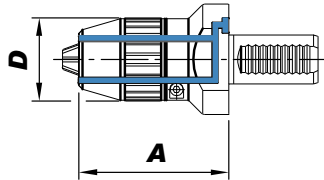

DIN 69880 (VDI) - mit Kühlmitteldüsen
DIN 69880 (VDI) - with coolant nozzles



VDI	Spannweite / Capacity mm	A mm	D mm	Art.-Nr. / Order no.
20	1-10	43,7	50	✘ 82-341020
25	1-13	87	50	✘ 82-341325
30	1-13	87	50	● 82-341330
30	1-16	92	55	● 82-341630
40	1-13	88	50	● 82-341340
40	1-16	93	55	● 82-341640
50	1-16	101,5	55	● 82-341650

Mitlaufende Zentrierspitze mit VDI-Schaft

Revolving tailstock centres with VDI shank

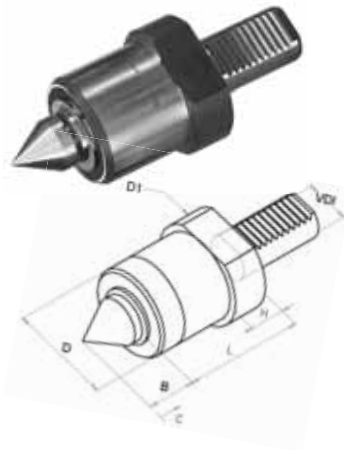

Gefedert
Spring-loaded

- speziell für den Einsatz auf CNC-Drehmaschinen
- für auswechselbare Einsätze
- Lieferung mit 1 Standardinsert (Fig. 1)
- especially for the use on CNC lathes
- for interchangeable inserts
- delivered with 1 standard insert (Fig. 1)

VDI	D mm	D1 mm	L mm	H mm	B mm	Federweg / Travelstroke max.	Art.-Nr. / Order no.
30	58	68	78	20	34	2,5	▶ 47-MZ2-30
40	58	83	80	22	34	2,5	▶ 47-MZ2-40

Einsätze
Inserts



Abb. / Fig.	E mm	B mm	G mm	Art.-Nr. / Order no.
1	28	34	-	▶ 47-MZ2-E1
2	28	40	7	▶ 47-MZ2-E2
2	28	40	12	▶ 47-MZ2-E3
3	58	36	25	▶ 47-MZ2-E4



Pendelhalter mit VDI-Schaft Floating chucks with VDI shank

Pendelhalter mit Innenkühlung Floating chucks with internal cooling

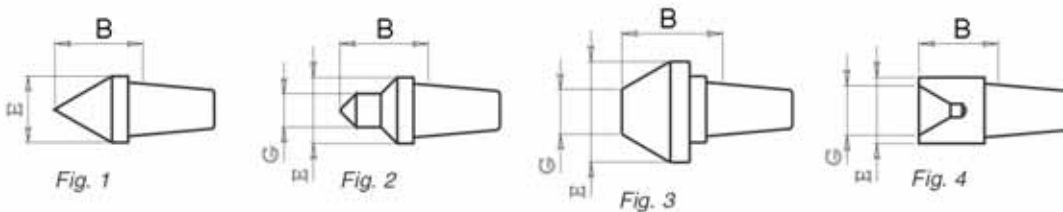
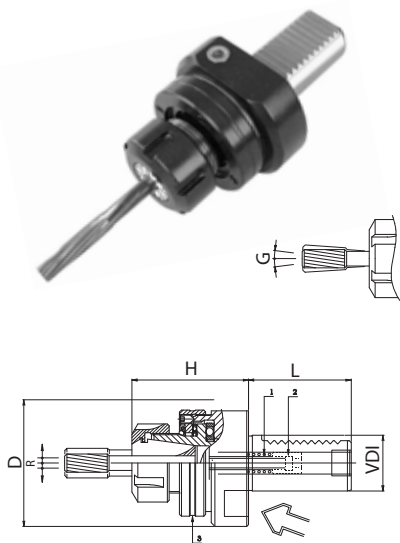

- mit einstellbarem Radialspiel
- Einstellbereiche: Freipendeln und Parallelpendeln
- Federkraft, Zentrierkraft und Freipendeln einstellbar
- radial clearance adjustable
- application: free and parallel floating
- spring force, centering force and floating adjustable

VDI	Spannzange / Collet	D mm	H mm	L mm	R max mm	G max mm	Art.-Nr. / Order no.
30	ER 25	68	64	55	1	1,5	▶ 47-PH-30-25
30	ER 32	68	72	55	1,5	1,5	▶ 47-PH-30-32
40	ER 32	83	74	63	1,5	1,5	▶ 47-PH-40-32
40	ER 40	83	74	63	1,5	1,5	▶ 47-PH-40-40

Räumwerkzeughalter mit VDI-Schaft Broach tool holders with VDI shank

Räumwerkzeughalter Broach tool holders

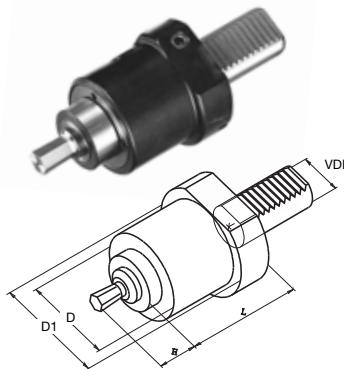

VDI	D mm	D1 mm	L mm	H mm	Aufnahme / Mounting	Art.-Nr. / Order no.
30	58	68	83	25	Ø 12	▶ 47-RHV-30-12
30	58	68	83	40	Ø 16	▶ 47-RHV-30-16
40	58	83	83	25	Ø 12	▶ 47-RHV-40-12
40	58	83	83	40	Ø 16	▶ 47-RHV-40-16

Räumstempel Broaching cutters



Räumstempel passend zu Aufnahme-Ø 12 Broaching cutters fitting to mounting-Ø 12

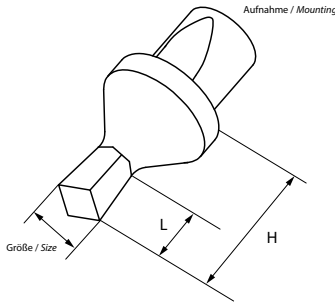

Form / Form	Größe / Size	H mm	L mm	Art.-Nr. / Order no.
Vierkant / Square	3	25	5	▶ 47-RST12/4-3,0
Vierkant / Square	4	25	6,5	▶ 47-RST12/4-4,0
Vierkant / Square	5	25	8,5	▶ 47-RST12/4-5,0
Vierkant / Square	5,5	25	9,5	▶ 47-RST12/4-5,5
Vierkant / Square	6	25	10,5	▶ 47-RST12/4-6,0
Vierkant / Square	7	25	13	▶ 47-RST12/4-7,0
Vierkant / Square	8	25	15,5	▶ 47-RST12/4-8,0
Vierkant / Square	9	25	21	▶ 47-RST12/4-9,0
Vierkant / Square	10	25	21	▶ 47-RST12/4-10,0
Vierkant / Square	11	25	21	▶ 47-RST12/4-11,0
Vierkant / Square	12	25	21	▶ 47-RST12/4-12,0
Vierkant / Square	13	25	21	▶ 47-RST12/4-13,0

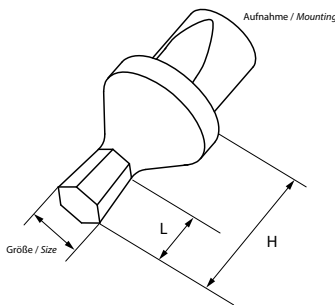

Form / Form	Größe / Size	H mm	L mm	Art.-Nr. / Order no.
Sechskant / Hexagon	1,5	25	3	▶ 47-RST12/6-1,5
Sechskant / Hexagon	2	25	3,5	▶ 47-RST12/6-2,0
Sechskant / Hexagon	2,5	25	4	▶ 47-RST12/6-2,5
Sechskant / Hexagon	3	25	5	▶ 47-RST12/6-3,0
Sechskant / Hexagon	3,5	25	6	▶ 47-RST12/6-3,5
Sechskant / Hexagon	4	25	6,5	▶ 47-RST12/6-4,0
Sechskant / Hexagon	5	25	8,5	▶ 47-RST12/6-5,0
Sechskant / Hexagon	5,5	25	9,5	▶ 47-RST12/6-5,5
Sechskant / Hexagon	6	25	10,5	▶ 47-RST12/6-6,0
Sechskant / Hexagon	7	25	13	▶ 47-RST12/6-7,0
Sechskant / Hexagon	8	25	15,5	▶ 47-RST12/6-8,0
Sechskant / Hexagon	9	25	21	▶ 47-RST12/6-9,0
Sechskant / Hexagon	10	25	21	▶ 47-RST12/6-10,0
Sechskant / Hexagon	11	25	21	▶ 47-RST12/6-11,0
Sechskant / Hexagon	12	25	21	▶ 47-RST12/6-12,0
Sechskant / Hexagon	13	25	21	▶ 47-RST12/6-13,0
Sechskant / Hexagon	14	25	21	▶ 47-RST12/6-14,0

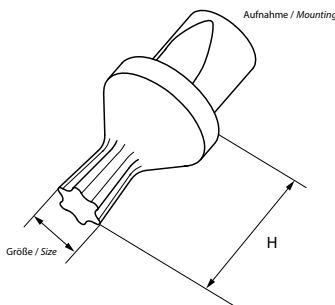

Form / Form	Größe / Size	H mm	Art.-Nr. / Order no.
Torx / Torx	6	25	▶ 47-RST12/T-6,0
Torx / Torx	8	25	▶ 47-RST12/T-8,0
Torx / Torx	10	25	▶ 47-RST12/T-10,0
Torx / Torx	15	25	▶ 47-RST12/T-15,0
Torx / Torx	20	25	▶ 47-RST12/T-20,0
Torx / Torx	25	25	▶ 47-RST12/T-25,0
Torx / Torx	27	25	▶ 47-RST12/T-27,0
Torx / Torx	30	25	▶ 47-RST12/T-30,0
Torx / Torx	40	25	▶ 47-RST12/T-40,0
Torx / Torx	45	25	▶ 47-RST12/T-45,0
Torx / Torx	50	25	▶ 47-RST12/T-50,0



Räumstempel Broaching cutters

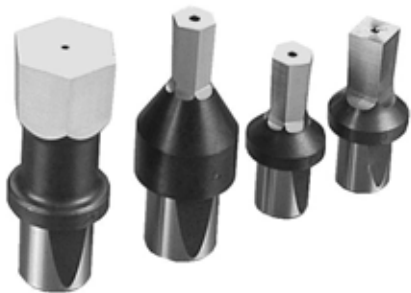

Räumstempel passend zu Aufnahme-Ø 16 Broaching cutters fitting to mounting-Ø 16

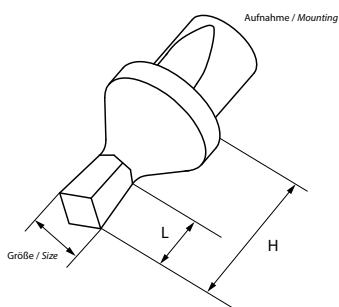

Form / Form	Größe / Size	H mm	L mm	Art.-Nr. / Order no.
Vierkant / Square	3	40	5	▶ 47-RST16/4-3,0
Vierkant / Square	4	40	6,5	▶ 47-RST16/4-4,0
Vierkant / Square	5	40	8,5	▶ 47-RST16/4-5,0
Vierkant / Square	6	40	10,5	▶ 47-RST16/4-6,0
Vierkant / Square	7	40	13	▶ 47-RST16/4-7,0
Vierkant / Square	8	40	15,5	▶ 47-RST16/4-8,0
Vierkant / Square	9	40	17,5	▶ 47-RST16/4-9,0
Vierkant / Square	10	40	18,5	▶ 47-RST16/4-10,0
Vierkant / Square	11	40	20	▶ 47-RST16/4-11,0
Vierkant / Square	12	40	20	▶ 47-RST16/4-12,0
Vierkant / Square	13	40	28	▶ 47-RST16/4-13,0
Vierkant / Square	14	40	32	▶ 47-RST16/4-14,0
Vierkant / Square	15	40	32	▶ 47-RST16/4-15,0
Vierkant / Square	16	40	32	▶ 47-RST16/4-16,0
Vierkant / Square	17	40	32	▶ 47-RST16/4-17,0
Vierkant / Square	18	40	32	▶ 47-RST16/4-18,0
Vierkant / Square	19	40	32	▶ 47-RST16/4-19,0
Vierkant / Square	20	40	32	▶ 47-RST16/4-20,0

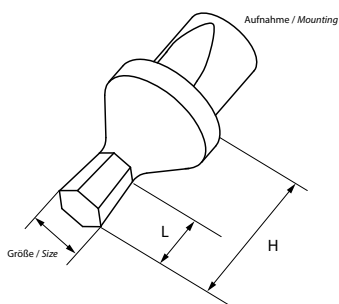

Form / Form	Größe / Size	H mm	L mm	Art.-Nr. / Order no.
Sechskant / Hexagon	3	40	5	▶ 47-RST16/6-3,0
Sechskant / Hexagon	3,5	40	6	▶ 47-RST16/6-3,5
Sechskant / Hexagon	4	40	6,5	▶ 47-RST16/6-4,0
Sechskant / Hexagon	5	40	8,5	▶ 47-RST16/6-5,0
Sechskant / Hexagon	6	40	10,5	▶ 47-RST16/6-6,0
Sechskant / Hexagon	7	40	13	▶ 47-RST16/6-7,0
Sechskant / Hexagon	8	40	15,5	▶ 47-RST16/6-8,0
Sechskant / Hexagon	9	40	17,5	▶ 47-RST16/6-9,0
Sechskant / Hexagon	10	40	18,5	▶ 47-RST16/6-10,0
Sechskant / Hexagon	11	40	20	▶ 47-RST16/6-11,0
Sechskant / Hexagon	12	40	20	▶ 47-RST16/6-12,0
Sechskant / Hexagon	13	40	28	▶ 47-RST16/6-13,0
Sechskant / Hexagon	14	40	32	▶ 47-RST16/6-14,0
Sechskant / Hexagon	15	40	32	▶ 47-RST16/6-15,0
Sechskant / Hexagon	16	40	32	▶ 47-RST16/6-16,0
Sechskant / Hexagon	17	40	32	▶ 47-RST16/6-17,0
Sechskant / Hexagon	18	40	32	▶ 47-RST16/6-18,0
Sechskant / Hexagon	19	40	32	▶ 47-RST16/6-19,0
Sechskant / Hexagon	20	40	32	▶ 47-RST16/6-20,0
Sechskant / Hexagon	21	40	32	▶ 47-RST16/6-21,0
Sechskant / Hexagon	22	40	32	▶ 47-RST16/6-22,0
Sechskant / Hexagon	23	40	32	▶ 47-RST16/6-23,0
Sechskant / Hexagon	24	40	32	▶ 47-RST16/6-24,0
Sechskant / Hexagon	25	40	32	▶ 47-RST16/6-25,0



Räumstempel Broaching cutters

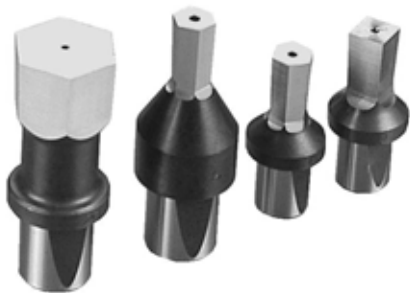

Räumstempel passend zu Aufnahme-Ø 16
Broaching cutters fitting to mounting-Ø 16

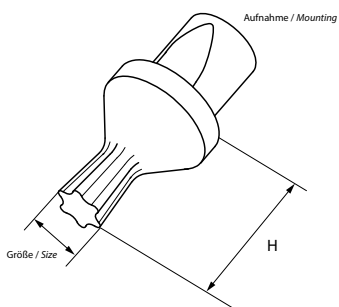

Form / Form	Größe / Size	H mm	Art.-Nr. / Order no.
Torx / Torx	6	40	47-RST16/T-10,0
Torx / Torx	8	40	47-RST16/T-15,0
Torx / Torx	10	40	47-RST16/T-20,0
Torx / Torx	15	40	47-RST16/T-25,0
Torx / Torx	20	40	47-RST16/T-27,0
Torx / Torx	25	40	47-RST16/T-30,0
Torx / Torx	27	40	47-RST16/T-40,0
Torx / Torx	30	40	47-RST16/T-45,0
Torx / Torx	40	40	47-RST16/T-50,0
Torx / Torx	45	40	47-RST16/T-55,0
Torx / Torx	50	40	47-RST16/T-60,0



Werkstückanschlag mit VDI-Schaft

Work piece stops with VDI shank

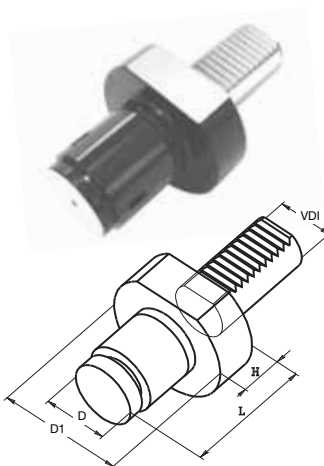

Mitlaufende Werkstückanschläge

Revolving work piece stops

- gefedert

- spring-loaded

VDI	D mm	D1 mm	L mm	H mm	Federweg / Stroke mm	Art.-Nr. / Order no.
20	35	50	58	16	3	47-MW-2035
20	56	50	58	16	3	47-MW-2056
30	35	68	70	20	3	47-MW-3035
30	56	68	70	20	3	47-MW-3056
40	44	83	78	22	3	47-MW-4044
40	60	83	78	22	3	47-MW-4060

Prüfdorne

Test arbors



Prüfdorne - DIN 69880 (VDI)

Test arbors - DIN 69880 (VDI)



VDI	D mm	D1 mm	L mm	B mm	Art.-Nr. / Order no.
16	30	40	120	15	83-PD-16-30
20	40	50	150	15	83-PD-20-40
25	40	58	150	15	83-PD-25-40
30	40	68	200	15	83-PD-30-40
40	40	83	200	15	83-PD-40-40
50	40	98	200	15	83-PD-50-40

Einrichtehalter

Setting holders

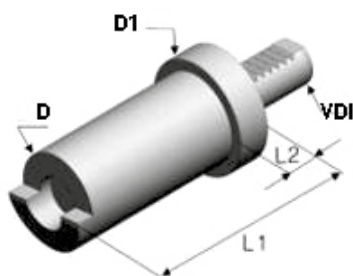

Einrichtehalter

Setting holders

VDI	D mm	D1 mm	L1 mm	L2 mm	Art.-Nr. / Order no.
16	30	40	100	15	47-EH-16
20	40	50	100	15	47-EH-20
25	40	58	100	15	47-EH-25
30	40	68	100	15	47-EH-30
40	40	83	100	15	47-EH-40
50	40	98	100	15	47-EH-50
60	40	123	100	15	47-EH-60



Zubehör für VDI-Halter Accessories for VDI-tool holders

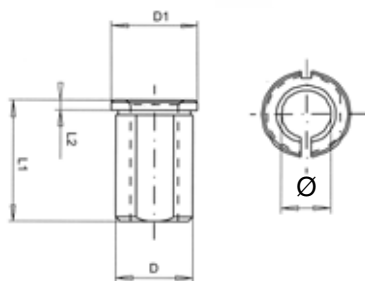

Reduzierbuchsen RZ, geschlitzt Reduction sleeves RZ, slotted

D mm	Ø mm	D1 mm	L1 mm	L2 mm	Art.-Nr. / Order no.
20	8, 10, 12, 14, 16	24	50	4	47-RZ-20-Ø
25	8, 10, 12, 14, 16, 18, 20	29	50	4	47-RZ-25-Ø
32	8, 10, 12, 14, 16, 18, 20, 25	36	60	4	47-RZ-32-Ø
40	10, 12, 14, 16, 18, 20, 25, 32	44	75	4	47-RZ-40-Ø
50	20, 25, 32, 40	54	75	4	47-RZ-50-Ø
60	25, 32, 40, 50	64	75	4	47-RZ-60-Ø

Reduzierbuchsen für Bohrstangenhalter Typ E2 Reduction sleeves for boring bar holders type E2

- Reduzierung zum Spannen von Werkzeugen mit Zylinderschaft
- reduction sleeve for clamping of tool holders with cylindrical shank

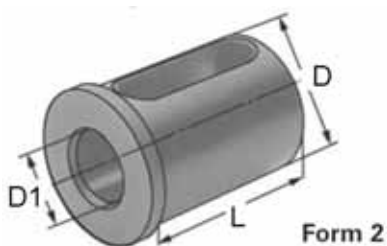
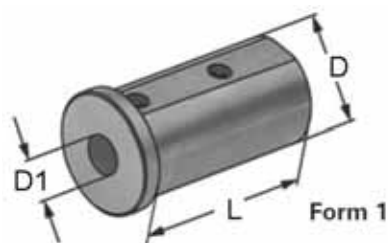

D mm	D1 mm	L mm	Form / Form	Art.-Nr. / Order no.
25	6	46	1	47-KRH-25-06
25	8	46	1	47-KRH-25-08
25	10	46	1	47-KRH-25-10
25	12	46	1	47-KRH-25-12
25	16	46	2	47-KRH-25-16
25	20	46	2	47-KRH-25-20
32	6	56	1	47-KRH-32-06
32	8	56	1	47-KRH-32-08
32	10	56	1	47-KRH-32-10
32	12	56	1	47-KRH-32-12
32	16	56	2	47-KRH-32-16
32	20	56	2	47-KRH-32-20
32	25	56	2	47-KRH-32-25
40	6	71	1	47-KRH-40-06
40	8	71	1	47-KRH-40-08
40	10	71	1	47-KRH-40-10
40	12	71	1	47-KRH-40-12
40	16	71	2	47-KRH-40-16
40	20	71	2	47-KRH-40-20
40	25	71	2	47-KRH-40-25
40	32	71	2	47-KRH-40-32

Kugelspritzdüsen Ball spray nozzles

- Material: Messing
- material: brass

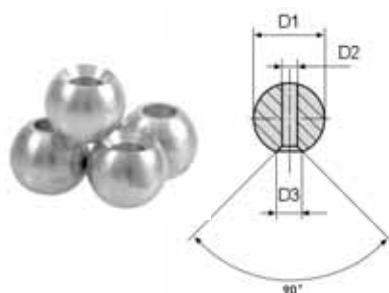

D mm	D1 mm	D2 mm	VE / Set	Art.-Nr. / Order no.
8	3,5	5,5	10 Stk. / 10 pcs.	47-KD-8
10	5	7	10 Stk. / 10 pcs.	47-KD-10
14	6	9	10 Stk. / 10 pcs.	47-KD-14

Abgabe nur in VE à 10 Stück, Preis versteht sich für 10 Stück
Only available in sets of 10 pieces, price refers to 10 pieces

Zubehör für VDI-Halter Accessories for VDI-tool holders

O-Ringe O-rings



Für / For	Art.-Nr. / Order no.
VDI 16	● 47-OR-VDI16
VDI 20	● 47-OR-VDI20
VDI 25	● 47-OR-VDI25
VDI 30	● 47-OR-VDI30
VDI 40	● 47-OR-VDI40
VDI 50	● 47-OR-VDI50
VDI 60	● 47-OR-VDI60

Abgabe nur in VE à 10 Stück, Preis versteht sich für 10 Stück
Only available in sets of 10 pieces, price refers to 10 pieces

Schutzstopfen Protective plugs



Schutzstopfen Z2, Stahl Protective plug Z2, steel

VDI	D mm	B mm	Art.-Nr. / Order no.
16	40	13	● 47-Z2-16S
20	50	16	● 47-Z2-20S
25	58	16	● 47-Z2-25S
30	68	16	● 47-Z2-30S
40	83	20	● 47-Z2-40S
50	98	20	● 47-Z2-50S
60	123	20	● 47-Z2-60S

Schutzstopfen Z2, Kunststoff Protective plug Z2, plastic



VDI	D mm	B mm	Art.-Nr. / Order no.
16	40	13	● 47-Z2-16K
20	50	16	● 47-Z2-20K
25	58	16	● 47-Z2-25K
30	68	16	● 47-Z2-30K
40	83	20	● 47-Z2-40K
50	98	20	● 47-Z2-50K
60	123	20	● 47-Z2-60K