

ALVAN[®]

Reaming Solution



S.C.A.M.I.

Table of Contents

INTEGRAL EXPANDING REAMERS 5



INTEGRAL EXPANDING REAMERS FOR HIGH FEEDS 17



EXPANDING REAMERS WITH MANDREL AND CUTTING RING 20



EXPANDING & FIXED HEADS 43



SERIES 5000 57

TSA SYSTEM 64



Modular System 73

Setup Instructions & Practical Suggestions 82



The reaming is a finishing operation for blind or through holes, when particular roughness and tolerance on diameter is requested and it is not obtained with the drilling. The choose of the correct reamer is conditioned by the drawing piece, type of machine and kind of material to work.

The SCAMI firm designs and optimizes the best solutions in precision of reaming field with the tools covered to ALVAN® brand.

The ALVAN® tools comprise fixed and expandable reaming solutions for standard diameters from 5.80 to 200 mm and special solutions and designs on request.



Integral Expanding Reamers



Features & Benefits

- Series: 3620 - 2441 - 3610 - 2431 - 2201 - 3627 - 3617
- Diameter range: 5,80 - 32,10 mm
- Available with central or radial through coolant
- Can be used for through or blind holes
- Cylindrical or Weldon shanks for improved concentricity
- High speed reamers for improved productivity

Code Description of the Integral Expanding Reamers

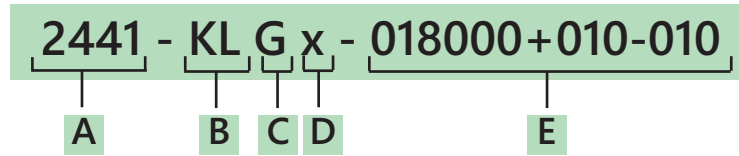

A A= Series 2441
 3620
 2431
 2201
 3610
 3627
 3617

B B= Cutting material and coating

Code	Description
KL	Hard metal cutting edges K05
KN	Hard metal cutting edges K05 N coated
KC	Hard metal cutting edges K05 C coated
KA	Hard metal cutting edges K05 A coated
KK	Hard metal cutting edges K05 K coated
KH	Hard metal cutting edges K05 H coated
SV	Cermet cutting edges P10
SN	Cermet cutting edges P10 N coated
SC	Cermet cutting edges P10 C coated
SA	Cermet cutting edges P10 A coated
SK	Cermet cutting edges P10 K coated
SH	Cermet cutting edges P10 H coated



N.B. On request is possible supplied tools in Carbide K10 and Cermet P20

C C= Lead-in

D D= Optional request:
 R = chip-breaker
 Z = oversized tapering
 H = half circular face

E E= Diameter and tolerance

SUMMARY								Short series	Central through tool coolant	Without through tool coolant	Radial through tool coolant	Central & Radial through tool coolant
	Series	Page	DIAMETERS mm					Long series	Central through tool coolant	Without through tool coolant	Radial through tool coolant	Central & Radial through tool coolant
			5,80	9,60	16,60	20,10	32,10					
INTEGRAL EXPANDING REAMERS	2431	16										
	2441	13										
	3610	15										
	3620	12										
	2201	14										
INTEGRAL EXPANDING REAMERS FOR HIGH FEEDS	3617	18										
	3627	17										

-  Reamers with central through tool coolant.
-  Reamers with radial through tool coolant.

STANDARD SPEED REAMING

Hard metal brazed carbide

MATERIAL TO WORK	N / mm ²	Reamer Ø mm	STOCK ALLOWANCE Ø mm	SURFACE SPEED m/min	FEED mm/rev	LUBRICANT
Mild Steel Unalloyed Low alloyed	Up to 600	6 to 10 10 - 22 22 - 32	0,10 - 0,20 0,15 - 0,25 0,20 - 0,40	7 - 15	0,15 - 0,30 0,25 - 0,50 0,30 - 0,80	Emulsible oil Cutting oil
Structural steel Fused Metal	Greater than 600	6 to 10 10 - 22 22 - 32	0,10 - 0,20 0,15 - 0,25 0,20 - 0,30	6 - 10	0,10 - 0,30 0,20 - 0,40 0,30 - 0,60	Emulsible oil Cutting oil
Alloy steel Stainless steel	400 - 1000	6 to 10 10 - 22 22 - 32	0,10 - 0,20 0,15 - 0,25 0,20 - 0,30	4 - 8	0,10 - 0,30 0,20 - 0,40 0,30 - 0,60	Emulsible oil Cutting oil
Strongly alloy steel Steel with manganese	800 - 1500	6 to 10 10 - 22 22 - 32	0,10 - 0,20 0,15 - 0,25 0,20 - 0,30	3 - 6	0,10 - 0,20 0,15 - 0,40 0,30 - 0,50	Emulsible oil Cutting oil
Grey cast iron Spheroidal cast iron (pearlitic) Malleable cast iron	Up to 200HB Greater than 200HB	6 to 10 10 - 22 22 - 32	0,10 - 0,20 0,15 - 0,30 0,30 - 0,40	≤200 HB 15 - 30 >200 HB 10 - 20	0,20 - 0,50 0,40 - 0,60 0,60 - 1,20	Oil Emulsible oil Cutting oil
Spheroidal cast iron (ferritic)	300 - 700	6 to 10 10 - 22 22 - 32	0,10 - 0,20 0,15 - 0,25 0,20 - 0,30	8 - 12	0,15 - 0,30 0,40 - 0,60 0,50 - 1,00	Emulsible oil Cutting oil
Copper and alloys Brass	Up to 500	6 to 10 10 - 22 22 - 32	0,10 - 0,25 0,15 - 0,25 0,25 - 0,40	10 - 18	0,15 - 0,40 0,20 - 0,60 0,25 - 0,90	Emulsible oil
Bronze Bronze phosphorous	Up to 600	6 to 10 10 - 22 22 - 32	0,10 - 0,25 0,15 - 0,25 0,25 - 0,40	10 - 20	0,15 - 0,40 0,25 - 0,60 0,50 - 0,80	Emulsible oil Cutting oil
Alluminium and light alloys	Up to 500	6 to 10 10 - 22 22 - 32	0,10 - 0,20 0,15 - 0,30 0,20 - 0,40	15 - 30	0,20 - 0,40 0,30 - 0,60 0,40 - 1,00	Emulsible oil Oil Cutting oil
Titanium and alloys		6 to 10 10 - 22 22 - 32	0,10 - 0,20 0,15 - 0,25 0,20 - 0,30	5 - 8	0,15 - 0,30 0,20 - 0,40 0,30 - 0,50	Emulsible oil Cutting oil
Syntetic materials		6 to 10 10 - 22 22 - 32	0,10 - 0,20 0,15 - 0,25 0,20 - 0,30	15 - 30	0,20 - 0,50 0,40 - 0,80 0,50 - 1,40	Compressed air Dry Emulsible oil

HIGH SPEED & FEED REAMING

Coated Hard metal & Cermet
brazed carbide

Reamers are available coated N, C, A, K H, D				H.M. coated	CERMET	STRAIGHT FLUTES	HELICAL FLUTES
MATERIAL TO WORK	N / mm ²	Reamer Ø mm	STOCK ALLOWANCE Ø mm	SURFACE SPEED m/min	SURFACE SPEED m/min	FEED mm/rev	FEED mm/rev
Mild Steel Unalloyed	Up to 600	6 to 10	0,08 - 0,15	60 - 80	90 - 300 H coated	0,20 - 0,40	0,30 - 0,60
Low alloyed		10 - 18	0,15 - 0,25			0,40 - 0,60	0,40 - 1,00
Structural steel Fused Metal	Greater than 600	6 to 10	0,08 - 0,15	40 - 70	80 - 200 H coated	0,20 - 0,40	0,30 - 0,50
		10 - 18	0,15 - 0,25			0,30 - 0,60	0,30 - 0,80
	18 - 32	0,15 - 0,30	0,40 - 0,70	0,40 - 1,00			
Alloy steel Stainless steel	400 - 1000	6 to 10 10 - 18 18 - 32	0,08 - 0,15 0,15 - 0,25 0,15 - 0,30	30 - 40	50 - 60	0,20 - 0,40 0,30 - 0,60 0,40 - 0,70	0,30 - 0,50 0,30 - 0,80 0,40 - 1,00
Strongly alloy steel Steel with manganese	800 - 1500	6 to 10 10 - 18 18 - 32	0,08 - 0,15 0,15 - 0,25 0,15 - 0,30	20 - 40		0,15 - 0,30 0,20 - 0,50 0,30 - 0,60	0,20 - 0,40 0,30 - 0,60 0,40 - 0,80
Grey cast iron Spheroidal cast iron (pearlitic) Malleable cast iron	Up to 200HB Greater than 200HB	6 to 10 10 - 18 18 - 32	0,08 - 0,15 0,15 - 0,25 0,15 - 0,30	110 - 200		0,20 - 0,40 0,35 - 0,60 0,40 - 1,00	0,30 - 0,60 0,50 - 0,80 0,60 - 1,50
Spheroidal cast iron (ferritic)	300 - 700	6 to 10 10 - 18 18 - 32	0,08 - 0,15 0,15 - 0,25 0,15 - 0,30		90 - 140 K coated	0,20 - 0,40 0,35 - 0,60 0,40 - 1,00	0,30 - 0,60 0,50 - 0,80 0,60 - 1,50
Copper and alloys Brass	Up to 500	6 to 10 10 - 18 18 - 32	0,08 - 0,15 0,15 - 0,25 0,15 - 0,30	100 - 200		0,20 - 0,40 0,40 - 0,70 0,50 - 0,80	
Bronze Bronze phosphorous	Up to 600	6 to 10 10 - 18 18 - 32	0,08 - 0,15 0,15 - 0,25 0,15 - 0,30	80 - 160	100 - 300	0,15 - 0,30 0,20 - 0,40 0,30 - 0,60	
Alluminium and light alloys	Up to 500	6 to 10 10 - 18 18 - 32	0,08 - 0,15 0,15 - 0,25 0,15 - 0,30	on request		0,20 - 0,40 0,40 - 0,70 0,50 - 0,80	
Titanium and alloys		6 to 10 10 - 18 18 - 32	0,10 - 0,20 0,15 - 0,25 0,20 - 0,40	15 - 30		0,15 - 0,30 0,20 - 0,40 0,30 - 0,50	

HIGH SPEED FOR ALUMINIUM REAMING

Aluminium with silicon greater than 10% - brazed carbide with PKD

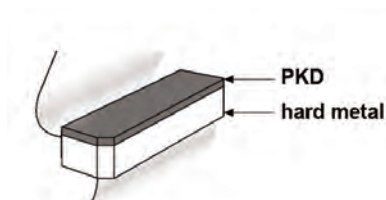

- Surface speed up to 1500 m/min
- When using PKD reamers a machine tool with high rigidity and absolute precision is a minimum requirement
- Each application must be assessed by our technical department

LEAD-IN FOR STRAIGHT FLUTES

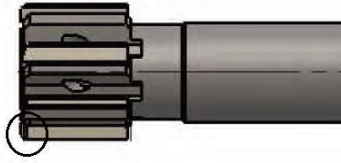

Lead-in 45° for standard speed

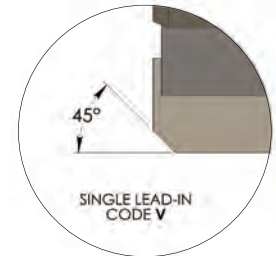

Lead-in 45° for high speed

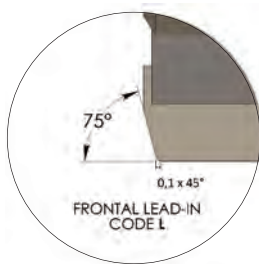

"L" lead-in to reduce the feed of 40% compared with the values on pages 8-9

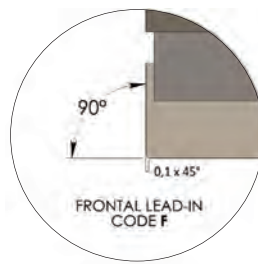

"F" lead-in to reduce the feed of 40% compared with the values on pages 8-9

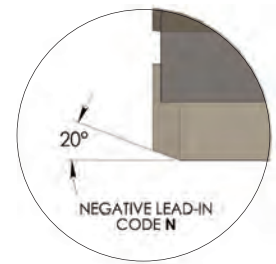

"N" lead-in ideal for through hole. Is it possible to increase the feed up to 100% of the values on pages 8-9

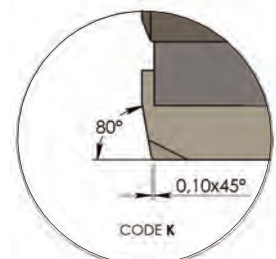
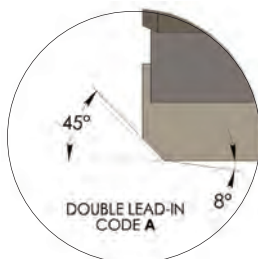
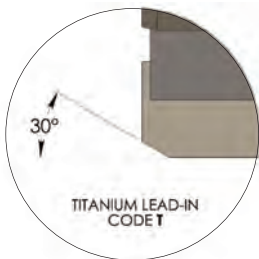

Chipbreaker

LEAD-IN FOR HELICAL FLUTES

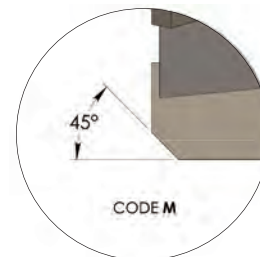
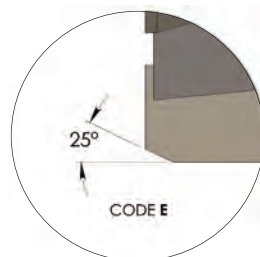

APPROACH ANGLES

MATERIAL TO WORK	TENSILE STRENGTH	APPROACH ANGLE*
Iron and mild steel (C < 0,2%)	50 Kg/mm ²	G - A - E
Mild steel (C 0,2 < 0,3%)	60 Kg/mm ²	N - A - E
Mild steel (C 0,3 < 0,4%)	70 Kg/mm ²	N - A - E
Mild steel (C 0,4 < 0,5%)	80 Kg/mm ²	N - A - E
Alloy steel	≤ 80 Kg/mm ²	G - N - A - E
Alloy steel	90 Kg/mm ²	G - N - E
Alloy steel	100 Kg/mm ²	G - N - M
Alloy steel	> 100 Kg/mm ²	G - N - M
Stainless and refractory steel	from 50 Kg/mm ² to 90 kg/ mm ²	G - N - M
Grey, spheroidal and malleable cast iron	from 150 HB to 320 HB	V - N - E
Titanium and titanium alloy		T - E
Pure copper		G - N - E
Electrolytic copper		G - N - E
Brass / Bronze		G - N - E
Aluminium alloy < 10% Si		V - A - E
Aluminium alloy > 11% Si		V - E
Magnesium alloy		G - A - E
Thermoplastic material		V - E
Thermosetting resins		V - E
Stiffened synthetic material		V - E

*Do not use negative lead-in on blind holes

Negative lead-in "N" can be used on large range of materials: please apply to our technical department.

Cylindrical shank - SHORT SERIES

Series 3620
through holes
with radial
tool coolant

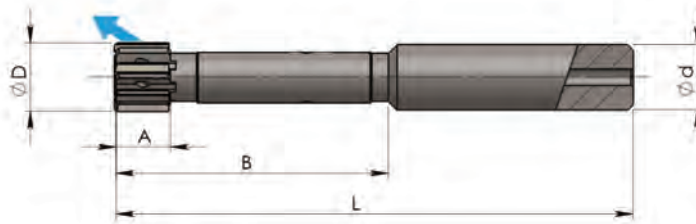

Hexagon
socket



Ø D mm	B mm	A mm	L mm	Ø d ^{h7} mm	N. of teeth	S
5,80 - 6,60	40	8	78	12	4	1,5
6,61 - 7,60	40	8	78	12	4	2
7,61 - 8,60	40	10	78	12	4	2,5
8,61 - 9,60	50	10	88	12	4	2,5
9,61 - 10,60	50	10	95	12	6	3
10,61 - 11,60	50	10	95	12	6	3
11,61 - 12,60	50	10	95	12	6	3
12,61 - 13,60	50	10	95	12	6	4
13,61 - 14,60	50	10	95	12	6	4
14,61 - 15,60	50	10	95	12	6	4
15,61 - 16,60	50	10	100	16	6	4
16,61 - 17,60	50	10	100	16	6	5
17,61 - 18,60	50	12	100	16	6	5
18,61 - 19,10	60	12	120	20	6	5
19,11 - 20,10	60	12	120	20	6	5
20,11 - 21,10	60	12	120	20	6	5
21,11 - 22,10	60	12	120	20	6	6
22,11 - 23,10	60	12	120	20	6	6
23,11 - 24,10	60	12	120	20	6	6
24,11 - 25,10	60	12	120	20	6	6
25,11 - 26,10	75	12	135	25	6	6
26,11 - 27,10	75	16	135	25	6	6
27,11 - 28,10	75	16	135	25	6	8
28,11 - 29,10	75	16	135	25	6	8
29,11 - 30,10	75	16	135	25	6	8
30,11 - 31,10	75	16	135	25	6	8
31,11 - 32,10	75	16	135	25	6	8

Cylindrical shank - SHORT SERIES

Series 2441
blind holes with
central through tool coolant

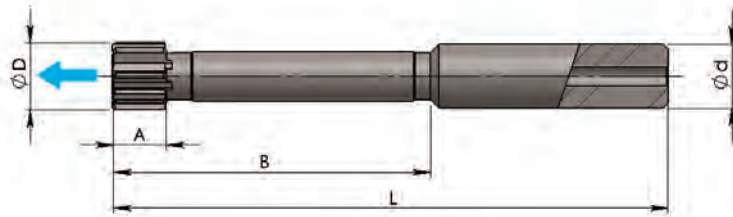

Ø D mm	B mm	A mm	L mm	Ø d ^{h7} mm	N. of teeth	S
5,80 - 6,60	40	8	80	12	4	1,5
6,61 - 7,60	40	8	80	12	4	2
7,61 - 8,60	40	10	80	12	4	2,5
8,61 - 9,60	50	10	90	12	4	2,5
9,61 - 10,60	50	10	95	12	6	3
10,61 - 11,60	60	10	105	12	6	3
11,61 - 12,60	60	10	105	12	6	3
12,61 - 13,60	60	10	105	12	6	4
13,61 - 14,60	70	10	115	12	6	4
14,61 - 15,60	70	10	115	12	6	4
15,61 - 16,60	80	10	130	16	6	4
16,61 - 17,60	80	10	130	16	6	5
17,61 - 18,60	90	12	140	16	6	5
18,61 - 19,10	90	12	150	20	6	5
19,11 - 20,10	100	12	160	20	6	5
20,11 - 21,10	100	12	160	20	6	5
21,11 - 22,10	100	12	160	20	6	6
22,11 - 23,10	100	12	160	20	6	6
23,11 - 24,10	100	12	160	20	6	6
24,11 - 25,10	100	12	160	20	6	6
25,11 - 26,10	110	12	170	25	6	6
26,11 - 27,10	110	16	170	25	6	6
27,11 - 28,10	110	16	170	25	6	8
28,11 - 29,10	110	16	170	25	6	8
29,11 - 30,10	110	16	170	25	6	8
30,11 - 31,10	110	16	170	25	6	8
31,11 - 32,10	110	16	170	25	6	8

Cylindrical shank - SHORT SERIES

Only for "Sliding head lathe"

Series 2201
blind holes with
central through tool coolant

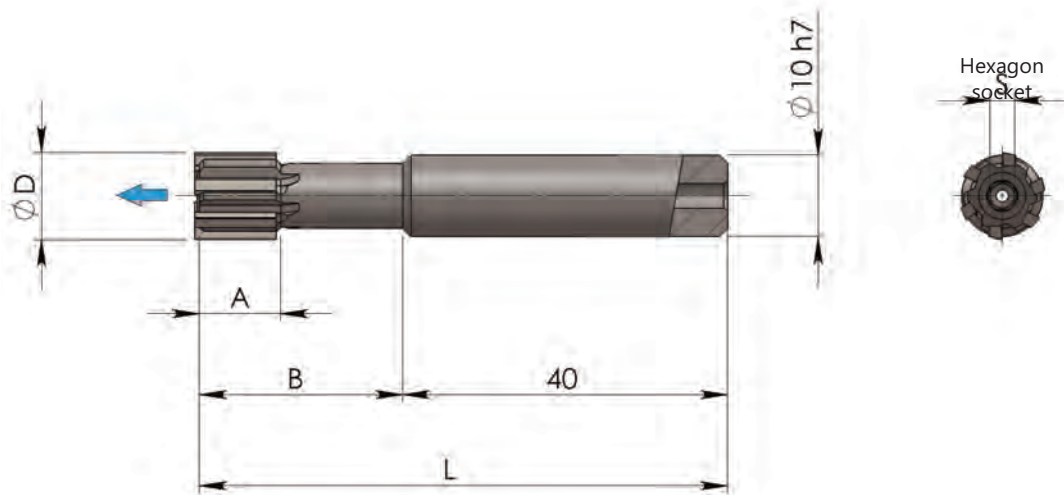

Ø D mm	B mm	A mm	L mm	N. of teeth	S
5,80 - 6,60	25	8	65	4	1,5
6,61 - 7,60	25	8	65	4	2
7,61 - 8,60	40	10	80	4	2,5
8,61 - 9,60	40	10	80	4	2,5
9,61 - 10,60	40	10	80	6	3
10,61 - 11,60	40	10	80	6	3
11,61 - 12,60	40	10	80	6	3
12,61 - 13,60	40	10	80	6	4
13,61 - 14,60	40	10	80	6	4
14,61 - 15,60	40	10	80	6	4
15,61 - 16,60	40	10	80	6	4

- Throw away until Ø 7,60 mm - for bigger diameters rebrazed one time
- Carbide K or Cermet S
- Order minimum 2 pcs (new)
- Delivered in 4 weeks (new and rebrazed ones)

Cylindrical shank - LONG SERIES

Series 3610
through holes
with radial through
tool coolant

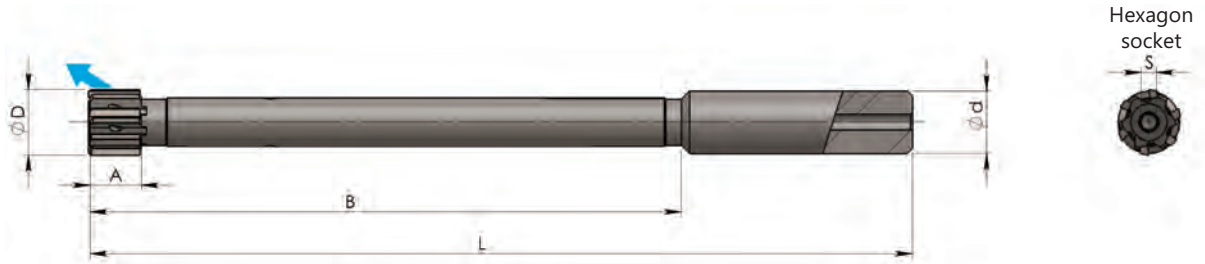

Ø D mm	B mm	A mm	L mm	Ø d ^{h7} mm	N. of teeth	S
5,80 - 6,60	85	8	123	12	4	1,5
6,61 - 7,60	85	8	123	12	4	2
7,61 - 8,60	85	10	123	12	4	2,5
8,61 - 9,60	85	10	123	12	4	2,5
9,61 - 10,60	115	10	160	12	6	3
10,61 - 11,60	115	10	160	12	6	3
11,61 - 12,60	115	10	160	12	6	3
12,61 - 13,60	115	10	160	12	6	4
13,61 - 14,60	115	10	160	12	6	4
14,61 - 15,60	115	10	160	12	6	4
15,61 - 16,60	130	10	180	16	6	4
16,61 - 17,60	130	10	180	16	6	5
17,61 - 18,60	130	12	180	16	6	5
18,61 - 19,10	140	12	200	20	6	5
19,11 - 20,10	140	12	200	20	6	5
20,11 - 21,10	140	12	200	20	6	5
21,11 - 22,10	140	12	200	20	6	6
22,11 - 23,10	140	12	200	20	6	6
23,11 - 24,10	140	12	200	20	6	6
24,11 - 25,10	140	12	200	20	6	6
25,11 - 26,10	150	12	210	25	6	6
26,11 - 27,10	150	16	210	25	6	6
27,11 - 28,10	150	16	210	25	6	8
28,11 - 29,10	150	16	210	25	6	8
29,11 - 30,10	150	16	210	25	6	8
30,11 - 31,10	150	16	210	25	6	8
31,11 - 32,10	150	16	210	25	6	8

Cylindrical shank - LONG SERIES

Series 2431
blind holes with
central through tool coolant

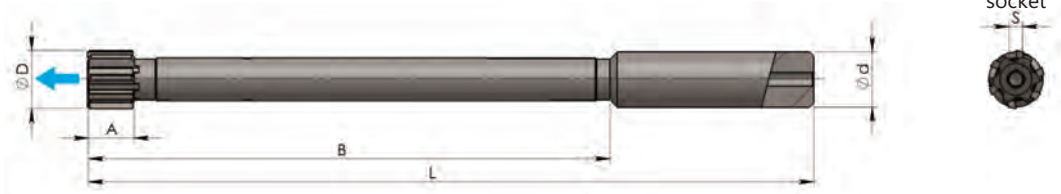

Ø D mm	B mm	A mm	L mm	Ø d ^{h7} mm	N. of teeth	S
5,80 - 6,60	85	8	123	12	4	1,5
6,61 - 7,60	85	8	123	12	4	2
7,61 - 8,60	85	10	123	12	4	2,5
8,61 - 9,60	85	10	123	12	4	2,5
9,61 - 10,60	115	10	160	12	6	3
10,61 - 11,60	115	10	160	12	6	3
11,61 - 12,60	115	10	160	12	6	3
12,61 - 13,60	115	10	160	12	6	4
13,61 - 14,60	115	10	160	12	6	4
14,61 - 15,60	115	10	160	12	6	4
15,61 - 16,60	130	10	180	16	6	4
16,61 - 17,60	130	10	180	16	6	5
17,61 - 18,60	130	12	180	16	6	5
18,61 - 19,10	140	12	200	20	6	5
19,11 - 20,10	140	12	200	20	6	5
20,11 - 21,10	140	12	200	20	6	5
21,11 - 22,10	140	12	200	20	6	6
22,11 - 23,10	140	12	200	20	6	6
23,11 - 24,10	140	12	200	20	6	6
24,11 - 25,10	140	12	200	20	6	6
25,11 - 26,10	150	12	210	25	6	6
26,11 - 27,10	150	16	210	25	6	6
27,11 - 28,10	150	16	210	25	6	8
28,11 - 29,10	150	16	210	25	6	8
29,11 - 30,10	150	16	210	25	6	8
30,11 - 31,10	150	16	210	25	6	8
31,11 - 32,10	150	16	210	25	6	8

Cylindrical shank - Left hand helical flutes

Series 3627
SHORT SERIES
with radial coolant

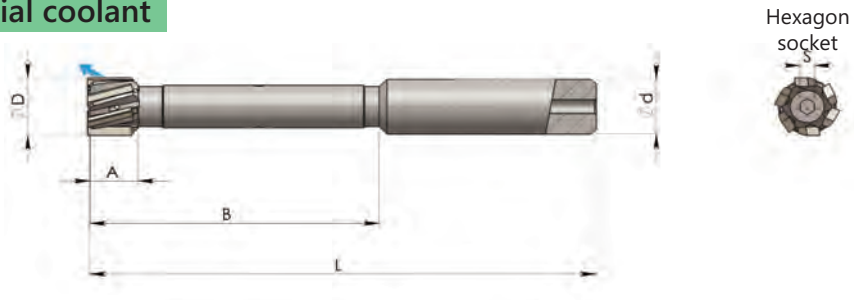

Ø D mm	B mm	A mm	L mm	Ø d ^{h7} mm	N. of teeth	S
5,80 - 6,60	40	8	80	12	4	1,5
6,61 - 7,60	40	8	80	12	4	2
7,61 - 8,60	40	10	80	12	4	2,5
8,61 - 9,60	50	10	90	12	4	2,5
9,61 - 10,60	50	10	95	12	6	3
10,61 - 11,60	60	10	105	12	6	3
11,61 - 12,60	60	10	105	12	6	3
12,61 - 13,60	60	10	105	12	6	4
13,61 - 14,60	70	10	115	12	6	4
14,61 - 15,60	70	10	115	12	6	4
15,61 - 16,60	80	10	130	16	6	4
16,61 - 17,60	80	10	130	16	6	5
17,61 - 18,60	90	12	140	16	6	5
18,61 - 19,10	90	12	150	20	6	5
19,11 - 20,10	100	12	160	20	6	5
20,11 - 21,10	100	12	160	20	6	5
21,11 - 22,10	100	12	160	20	6	6
22,11 - 23,10	100	12	160	20	6	6
23,11 - 24,10	100	12	160	20	6	6
24,11 - 25,10	100	12	160	20	6	6
25,11 - 26,10	110	12	170	25	6	6
26,11 - 27,10	110	16	170	25	6	6
27,11 - 28,10	110	16	170	25	6	8
28,11 - 29,10	110	16	170	25	6	8
29,11 - 30,10	110	16	170	25	6	8
30,11 - 31,10	110	16	170	25	6	8
31,11 - 32,10	110	16	170	25	6	8

Cylindrical shank - Left hand helical flutes

**Series 3617
LONG SERIES
with radial coolant**



Hexagon
socket

Ø D mm	B mm	A mm	L mm	Ø d ^{h7} mm	N. of teeth	S
5,80 - 6,60	85	8	123	12	4	1,5
6,61 - 7,60	85	8	123	12	4	2
7,61 - 8,60	85	10	123	12	4	2,5
8,61 - 9,60	85	10	123	12	4	2,5
9,61 - 10,60	115	10	160	12	6	3
10,61 - 11,60	115	10	160	12	6	3
11,61 - 12,60	115	10	160	12	6	3
12,61 - 13,60	115	10	160	12	6	4
13,61 - 14,60	115	10	160	12	6	4
14,61 - 15,60	115	10	160	12	6	4
15,61 - 16,60	130	10	180	16	6	4
16,61 - 17,60	130	10	180	16	6	5
17,61 - 18,60	130	12	180	16	6	5
18,61 - 19,10	140	12	200	20	6	5
19,11 - 20,10	140	12	200	20	6	5
20,11 - 21,10	140	12	200	20	6	5
21,11 - 22,10	140	12	200	20	6	6
22,11 - 23,10	140	12	200	20	6	6
23,11 - 24,10	140	12	200	20	6	6
24,11 - 25,10	140	12	200	20	6	6
25,11 - 26,10	150	12	210	25	6	6
26,11 - 27,10	150	16	210	25	6	6
27,11 - 28,10	150	16	210	25	6	8
28,11 - 29,10	150	16	210	25	6	8
29,11 - 30,10	150	16	210	25	6	8
30,11 - 31,10	150	16	210	25	6	8
31,11 - 32,10	150	16	210	25	6	8

EXPANDING MONOBLOC REAMERS OLD SERIES - ONLY ON REQUEST

Please Note:

There are several series of reamers which we decided to don't put in the catalog. These reamers are still available on request. They are supplied in 4/6 weeks from the receipt of the order and it is requested a order minimum of 3 pieces for each diameter.

	Code	Series	Shank	Hole	Coolant	Diameter	Teeth
EXPANDING REAMERS	2420	short	cylindrical	through & blind	no	5,80÷20,10	straight
	2421	short	cylindrical	blind	central	5,80÷20,10	straight
	2440	short	cylindrical	through & blind	no	5,80÷32,10	straight
	2430	long	cylindrical	through & blind	no	5,80÷32,10	straight
	2450	short	Morse Taper	through & blind	no	5,80÷32,10	straight
	3650	short	Morse Taper	through	radial	5,80÷32,10	straight
	2400	long	Morse Taper	through & blind	no	5,80÷32,10	straight
	3600	long	Morse Taper	through	radial	5,80÷32,10	straight
FIXED REAMERS	1610	long	cylindrical	through	radial	9,60÷32,10	helical flutes
	161W	long	Morse Taper	through	radial	9,60÷32,10	helical flutes
	1620	short	cylindrical	through	radial	9,60÷32,10	helical flutes
	162W	short	Morse Taper	through	radial	9,60÷32,10	helical flutes

More information are available on our web site.

Expanding Cutting Rings

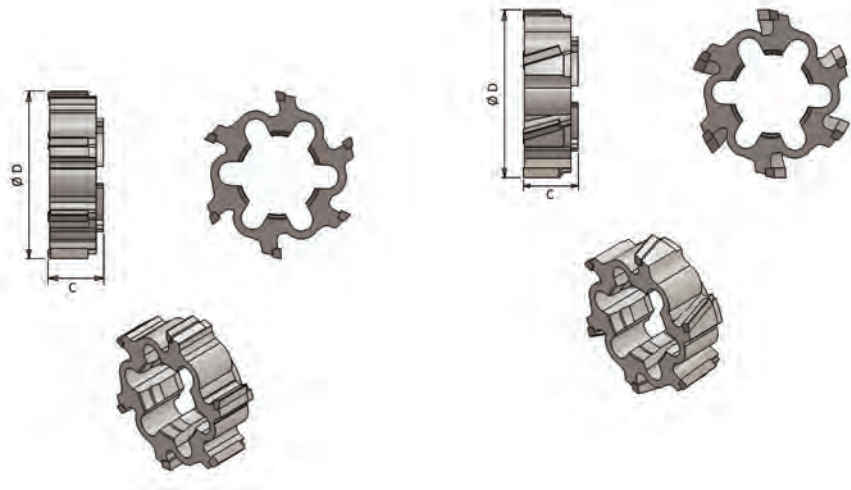

Ø D mm	Straight flutes		Helical flutes	Number of teeth
	C mm	C mm	C mm	
17,60 - 21,59	11	-	-	6
21,60 - 25,59	12	-	-	6
25,60 - 32,59	14	-	-	6
32,60 - 45,59	16	16	16	6
45,60 - 79,59	18,5	18,5	18,5	6
79,60 - 100,59	18,5	18,5	18,5	8
100,60 - 110,59	18,5	18,5	18,5	10
110,60 - 200,59	18,5	18,5	18,5	12

Features & Benefits

- The ALVAN® cutting rings are modular and compatible with all the reamers indicated on page
- We supply a regrinding and re-brazing service of the damage and worn cutting edges (please consult our technical department).
- The cutting edges are in an asymmetric way to assure the best roundness of the hole
- Holes with restricted tolerances (ISO 5 and ISO 6) can be supplied and the expansion assures a perfect holding of the reaming diameter.
- The ALVAN® cutting rings are manufactured to the middle of the hole tolerance so they must be assembled and adjusted to the same diameter. It is important to comply with this direction in order to have a good functioning and life of the tool.
- LEFT HAND HELICAL FLUTES CUTTING RINGS from diameter 32,60÷200,59 mm ON REQUEST.

Code Description of the Cutting Rings

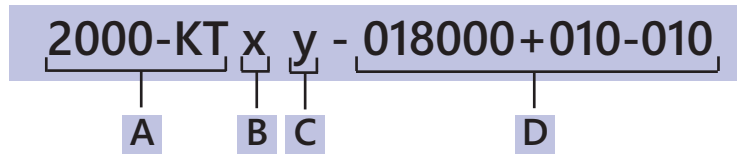

A A= Cutting material and coated

Code	Description
2000-KT	Hard metal cutting edges K05
2TIN-KT	Hard metal cutting edges K05 N coated
2TIC-KT	Hard metal cutting edges K05 C coated
2TIA-KT	Hard metal cutting edges K05 A coated
2TLK-KT	Hard metal cutting edges K05 K coated
2TLH-KT	Hard metal cutting edges K05 H coated
2AVC-ST	Cermet cutting edges P10
2ANC-ST	Cermet cutting edges P10 N coated
2ACC-ST	Cermet cutting edges P10 C coated
2AAC-ST	Cermet cutting edges P10 A coated
2ALK-ST	Cermet cutting edges P10 K coated
2ALH-ST	Cermet cutting edges P10 H coated

N.B. On request it is possible supply tools in Carbide K10 and Cermet P20

B B= Lead-in

C C= Optional request:
 R = chip-breaker
 Z = oversized tapering
 H = half circular face

D D= Diameter and tolerance

SUMMARY								Short series	Central through tool coolant	Radial through tool coolant	Central & Radial through tool coolant
	Series	Page	DIAMETERS mm					Long series	Central through tool coolant	Radial through tool coolant	Central & Radial through tool coolant
			17,60	20,10	32,10	100,60	200,60				
EXPANDING REAMERS WITH CUTTING RING	4500	31									
	4500A	33									
	4505	32									
	4505A	34									
	4550	27									
	4550A	29									
	4555	28									
	4555A	30									
EXPANDING REAMERS WITH CUTTING RING "COMPOSIT" MODULAR SYSTEM	4330	35									
	4335	36									
	4350	37-39									
	4355	38-40									
	4300	41									
	4305	39-42									

STANDARD SPEED REAMING

Hard metal brazed carbide

MATERIAL TO WORK	N / mm ²	Reamer Ø mm	STOCK ALLOWANCE Ø mm	SURFACE SPEED m/min	FEED mm/rev	LUBRICANT
Mild Steel	Up to 600	18 - 22	0,15 - 0,25	7 - 15	0,25 - 0,50	Emulsible oil
Unalloyed		22 - 40	0,20 - 0,40		0,30 - 0,80	Cutting oil
Low alloyed	Greater than 600	40 - 50	0,30 - 0,40	6 - 10	0,60 - 1,00	Emulsible oil
Structural steel		50 - 70	0,35 - 0,50		0,60 - 1,20	
Fused Metal		70 - 100	0,40 - 0,50		0,80 - 1,50	Cutting oil
		100 - 200				
Alloy steel	400 - 1000	18 - 22	0,15 - 0,25	4 - 8	0,20 - 0,40	Emulsible oil
Stainless steel		22 - 40	0,20 - 0,30		0,30 - 0,60	Cutting oil
		40 - 50	0,30 - 0,40		0,40 - 0,80	
		50 - 70	0,35 - 0,50		0,50 - 0,90	
		70 - 100	0,40 - 0,50		0,60 - 1,20	
		100 - 200				
Strongly alloy steel	800 - 1500	18 - 22	0,15 - 0,25	3 - 6	0,15 - 0,40	Emulsible oil
Steel with manganese		22 - 40	0,20 - 0,30		0,30 - 0,50	Cutting oil
		40 - 50	0,30 - 0,40		0,30 - 0,70	
		50 - 70	0,35 - 0,50		0,40 - 0,80	
		70 - 100	0,40 - 0,50		0,50 - 1,00	
		100 - 200				
Grey cast iron	Up to 200HB	18 - 22	0,15 - 0,30	≤200 HB	0,40 - 0,60	Oil
Spheroidal cast iron (pearlitic)	Greater than 200HB	22 - 40	0,30 - 0,40	15 - 30	0,60 - 1,20	Emulsible oil
Malleable cast iron		50 - 70	0,30 - 0,40	>200 HB	0,75 - 1,50	Cutting oil
		70 - 100	0,35 - 0,50	10 - 20	0,80 - 1,60	
		100 - 200	0,40 - 0,50		1,00 - 1,80	
Spheroidal cast iron (ferritic)	300 - 700	18 - 22	0,15 - 0,25	8 - 12	0,40 - 0,60	Emulsible oil
		22 - 40	0,20 - 0,30		0,50 - 1,00	Cutting oil
		40 - 50	0,30 - 0,40		0,75 - 1,50	
		50 - 70	0,35 - 0,50		0,80 - 1,60	
		70 - 100	0,40 - 0,50		1,00 - 1,80	
		100 - 200				
Copper and alloys	Up to 500	18 - 22	0,15 - 0,25	10 - 18	0,20 - 0,60	Emulsible oil
Brass		22 - 40	0,25 - 0,40		0,25 - 0,90	
		40 - 50	0,30 - 0,40		0,40 - 1,10	
		50 - 70	0,35 - 0,50		0,50 - 1,20	
		70 - 100	0,40 - 0,50		0,60 - 1,50	
		100 - 200				
Bronze	Up to 600	18 - 22	0,15 - 0,25	10 - 20	0,25 - 0,60	Emulsible oil
Bronze phosphorous		22 - 40	0,25 - 0,40		0,50 - 0,80	Cutting oil
		40 - 50	0,30 - 0,40		0,60 - 1,00	
		50 - 70	0,35 - 0,50		0,70 - 1,10	
		70 - 100	0,40 - 0,50		0,80 - 1,20	
		100 - 200				
Alluminium and light alloys	Up to 500	18 - 22	0,15 - 0,30	15 - 30	0,30 - 0,60	Emulsible oil
		22 - 40	0,20 - 0,40		0,40 - 1,00	Oil
		40 - 50	0,30 - 0,40		0,75 - 1,50	
		50 - 70	0,35 - 0,50		0,80 - 1,60	
		70 - 100	0,40 - 0,50		0,90 - 1,80	Cutting oil
		100 - 200				
Titanium and alloys		18 - 22	0,15 - 0,25	5 - 8	0,20 - 0,40	Emulsible oil
		22 - 40	0,20 - 0,30		0,30 - 0,50	Cutting oil
		40 - 50	0,30 - 0,40		0,40 - 0,60	
		50 - 70	0,35 - 0,50		0,60 - 0,80	
		70 - 100	0,40 - 0,50		0,80 - 1,20	
		100 - 200				
Syntetic materials		18 - 22	0,15 - 0,25	15 - 30	0,40 - 0,80	Compressed air
		22 - 40	0,20 - 0,30		0,50 - 1,40	Dry
		40 - 50	0,30 - 0,40		0,80 - 1,50	
		50 - 70	0,35 - 0,50		0,90 - 1,60	
		70 - 100	0,40 - 0,50		1,00 - 1,80	Emulsible oil
		100 - 200				

HIGH SPEED & FEED REAMING

Coated Hard metal & Cermet
brazed carbide

Reamers are available coated N, C, A, K, H, D.				H.M. coated	CERMET	STRAIGHT FLUTES	HELICAL FLUTES
MATERIAL TO WORK	N / mm ²	Reamer Ø mm	STOCK ALLOWANCE Ø mm	SURFACE SPEED m/min	SURFACE SPEED m/min	FEED mm/rev	FEED mm/rev
Mild Steel Unalloyed	Up to 600	18 - 40	0,15 - 0,30	60 - 80	90 - 300 H coated	0,50 - 0,80	0,60 - 1,20
Low alloyed		40 - 80	0,20 - 0,40			0,50 - 1,00	0,80 - 1,60
Structural steel Fused Metal	Greater than 600	18 - 40	0,15 - 0,30	40 - 70	80 - 200 H coated	0,40 - 0,70	0,40 - 1,00
		40 - 80	0,20 - 0,40			0,50 - 0,80	0,60 - 1,40
Alloy steel Stainless steel	400 - 1000	18 - 40	0,15 - 0,30	30 - 40	50 - 60	0,40 - 0,70	0,40 - 1,00
		40 - 80	0,20 - 0,40			0,50 - 0,80	0,60 - 1,40
Strongly alloy steel Steel with manganese	800 - 1500	18 - 40	0,15 - 0,30	20 - 40		0,30 - 0,60	0,40 - 0,80
		40 - 80	0,20 - 0,40			0,40 - 0,80	0,50 - 1,00
Grey cast iron Spheroidal cast iron (pearlitic) Malleable cast iron	Up to 200HB	18 - 40	0,15 - 0,30	120 - 200		0,40 - 1,00	0,60 - 1,50
	Greater than 200HB	40 - 80	0,20 - 0,40			0,60 - 1,30	0,80 - 1,60
Spheroidal cast iron (ferritic)	300 - 700	18 - 40	0,15 - 0,30		90 - 140 K coated	0,40 - 1,00	0,60 - 1,50
Copper and alloys Brass	Up to 500	18 - 40	0,15 - 0,30	100 - 200		0,50 - 0,80	
		40 - 80	0,20 - 0,40			0,60 - 1,00	0,80 - 1,40
Bronze Bronze phosphorous	Up to 600	18 - 40	0,15 - 0,30	80 - 160	100 - 300	0,30 - 0,60	
		40 - 80	0,20 - 0,40			0,40 - 0,80	0,60 - 1,00
Aluminium and light alloys	Up to 500	18 - 40	0,15 - 0,30	on request		0,50 - 0,80	
		40 - 80	0,20 - 0,40			0,60 - 1,00	0,80 - 1,40
Titanium and alloys		18 - 40	0,20 - 0,40	15 - 30		0,30 - 0,50	
		40 - 80	0,30 - 0,40			0,40 - 0,60	0,50 - 0,70

HIGH SPEED FOR ALUMINIUM REAMING

Aluminium with silicon greater than 10% - brazed carbide with PKD

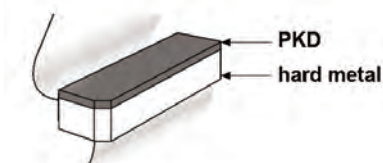

- Surface speed up to 1500 m/min
- When using PKD reamers a machine tool with high rigidity and absolute precision is a minimum requirement
- Each application must be assessed by our technical department

LEAD-IN FOR STRAIGHT FLUTES



Lead-in 45° for standard speed

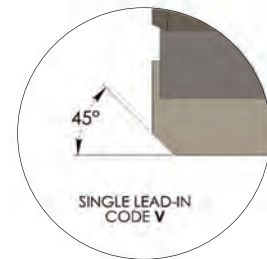

Lead-in 45° for high speed



"L" lead-in to reduce the feed of 40% compared with the values on pages 8-9

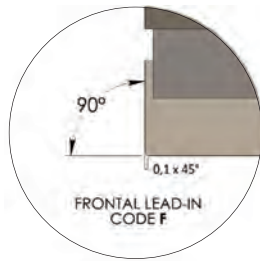

"F" lead-in to reduce the feed of 40% compared with the values on pages 8-9

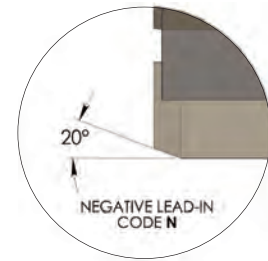

"N" lead-in ideal for through hole. Is it possible to increase the feed up to 100% of the values on pages 8-9

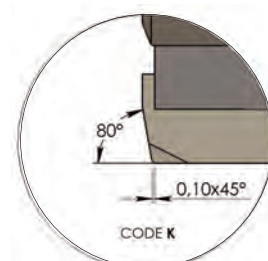
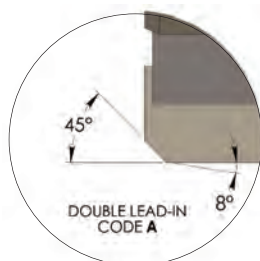

Chipbreaker

LEAD-IN FOR HELICAL FLUTES - from Ø 33,00

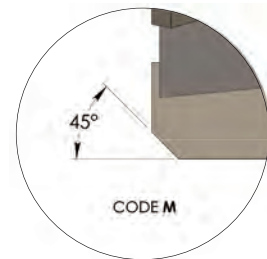
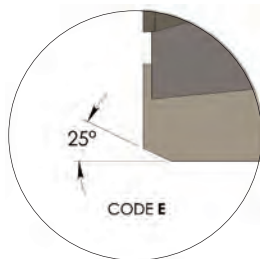

APPROACH ANGLES

MATERIAL TO WORK	TENSILE STRENGTH	APPROACH ANGLE*
Iron and mild steel (C < 0,2%)	50 Kg/mm ²	G - A - E
Mild steel (C 0,2 < 0,3%)	60 Kg/mm ²	N - A - E
Mild steel (C 0,3 < 0,4%)	70 Kg/mm ²	N - A - E
Mild steel (C 0,4 < 0,5%)	80 Kg/mm ²	N - A - E
Alloy steel	≤ 80 Kg/mm ²	G - N - A - E
Alloy steel	90 Kg/mm ²	G - N - E
Alloy steel	100 Kg/mm ²	G - N - M
Alloy steel	> 100 Kg/mm ²	G - N - M
Stainless and refractory steel	from 50 Kg/mm ² to 90 kg/ mm ²	G - N - M
Grey, spheroidal and malleable cast iron	from 150 HB to 320 HB	V - N - E
Titanium and titanium alloy		T - E
Pure copper		G - N - E
Electrolytic copper		G - N - E
Brass / Bronze		G - N - E
Aluminium alloy < 10% Si		V - A - E
Aluminium alloy > 11% Si		V - E
Magnesium alloy		G - A - E
Thermoplastic material		V - E
Thermosetting resins		V - E
Stiffened synthetic material		V - E

*Do not use negative lead-in on blind holes

Negative lead-in "N" can be used on large range of materials: please apply to our technical department.

Cylindrical shank - SHORT SERIES - with flat from Ø 17,60 to 100,59 mm

Series 4550
through holes
with radial through
tool coolant

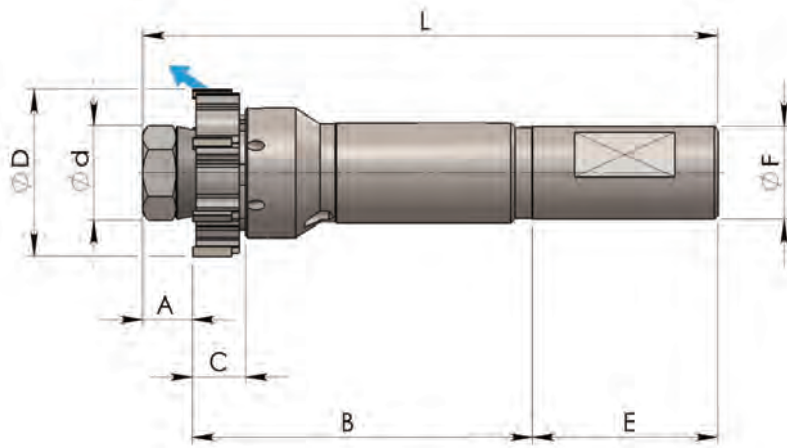

Ø D mm	Ø d mm	A mm	L mm	B mm	C mm	E mm	Ø F ^{H7} mm	Number of teeth
17,60-21,59	12	11	142	81	11	50	20	6
21,60-25,59	12	11	142	81	12	50	20	6
25,60-32,59	15,6	11	163	102	14	50	20	6
32,60-40,59	22	14	172	102	16	56	25	6
40,60-45,59	25,4	15	173	102	16	56	25	6
45,60-60,59	30	20,5	185,5	105	18,5	60	32	6
60,60-79,59	40	24,5	189,5	105	18,5	60	32	6
79,60-100,59	56	28,5	203,5	105	18,5	70	40	8

SPARE PARTS

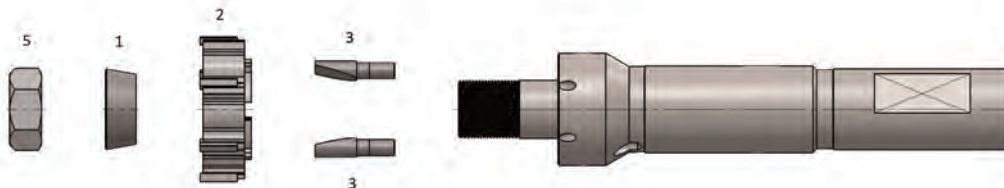

2= Cutting Ring

Ø D mm	Complete mandrel without cutting ring	Conical ring 1	Ring nut or nut 5	Wrench	Drive pin 3	Number of drive pin
17,60-21,59	4550-MC-010	2010-AC-010	2000-DA-010	hex 10	2000-CO-010	3
21,60-25,59	4550-MC-020	2010-AC-010	2000-DA-010	hex 10	2000-CO-020	3
25,60-32,59	4550-MC-030	2010-AC-020	2000-DA-020	hex 13	2000-CO-030	3
32,60-40,59	4550-MC-040	2010-AC-030	2000-DA-060	hex 19	2000-CO-040	2
40,60-45,59	4550-MC-050	2010-AC-040	2000-DA-090	hex 22	2000-CO-060	2
45,60-49,59	4550-MC-060	2010-AC-050	2000-GH-880	hook 30	2000-CO-060	2
49,60-60,59	4550-MC-070	2010-AC-050	2000-GH-880	hook 30	2000-CO-070	2
60,60-70,59	4550-MC-080	2010-AC-060	2000-GH-900	hook 40	2000-CO-080	2
70,60-79,59	4550-MC-090	2010-AC-060	2000-GH-900	hook 40	2000-CO-090	2
79,60-90,59	4550-MC-100	2010-AC-070	2000-GH-920	hook 56	2000-CO-090	2
90,60-100,59	4550-MC-110	2010-AC-070	2000-GH-920	hook 56	2000-CO-090	2

Cylindrical shank - SHORT SERIES - with flat from Ø 17,60 to 100,59 mm

Series 4555
blind holes
with radial through
tool coolant

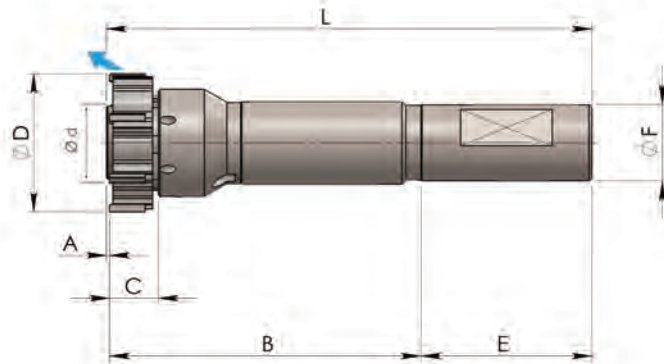

Ø D mm	Ø d mm	A mm	L mm	B mm	C mm	E mm	Ø F ^{h7} mm	Number of teeth
17,60-21,59	11,2	1	132	81	11	50	20	6
21,60-25,59	11,2	1	132	81	12	50	20	6
25,60-32,59	15,1	1	153	102	14	50	20	6
32,60-40,59	20,3	1	159	102	16	56	25	6
40,60-45,59	24,1	1	159	102	16	56	25	6
45,60-60,59	27,9	1,5	166,5	105	18,5	60	32	6
60,60-79,59	37,1	1,5	166,5	105	18,5	60	32	6
79,60-100,59	53,1	1,5	176,5	105	18,5	70	40	8

SPARE PARTS

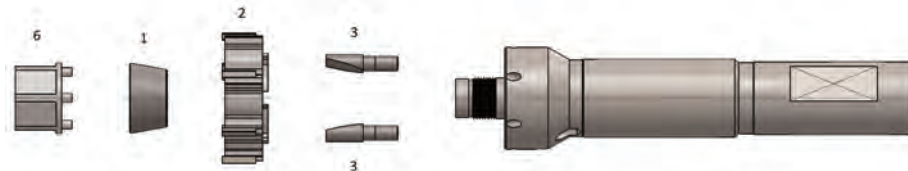

Ø D mm	Complete mandrel without cutting ring	Key 6	Wrench	Conical ring 1	Conical ring second expansion	Conical ring third expansion	Drive pin 3	Number of drive pin
17,60-21,59	4555-MC-010	4001-CH-015	hex 10	4001-AC-115	4001-AC-215	-	2000-CO-010	3
21,60-25,59	4555-MC-020	4001-CH-015	hex 10	4001-AC-115	4001-AC-215	-	2000-CO-020	3
25,60-29,59	4555-MC-030	4001-CH-025	hex 13	4001-AC-125	4001-AC-225	4001-AC-325	2000-CO-030	3
29,60-32,59	4555-MC-035	4001-CH-025	hex 13	4001-AC-125	4001-AC-225	4001-AC-325	2000-CO-040	2
32,60-36,59	4555-MC-040	4001-CH-035	hex 18	4001-AC-135	4001-AC-235	4001-AC-335	2000-CO-040	2
36,60-40,59	4555-MC-045	4001-CH-035	hex 18	4001-AC-135	4001-AC-235	4001-AC-335	2000-CO-050	2
40,60-45,59	4555-MC-050	4001-CH-045	hex 22	4001-AC-145	4001-AC-245	4001-AC-345	2000-CO-060	2
45,60-49,59	4555-MC-060	4001-CH-055	hex 26	4001-AC-155	4001-AC-255	4001-AC-355	2000-CO-060	2
49,60-55,59	4555-MC-070	4001-CH-055	hex 26	4001-AC-155	4001-AC-255	4001-AC-355	2000-CO-070	2
55,60-60,59	4555-MC-075	4001-CH-055	hex 26	4001-AC-155	4001-AC-255	4001-AC-355	2000-CO-080	2
60,60-65,59	4555-MC-080	4001-CH-065	hex 34	4001-AC-165	4001-AC-265	4001-AC-365	2000-CO-080	2
65,60-70,59	4555-MC-085	4001-CH-065	hex 34	4001-AC-165	4001-AC-265	4001-AC-365	2000-CO-090	2
70,60-79,59	4555-MC-090	4001-CH-065	hex 34	4001-AC-165	4001-AC-265	4001-AC-365	2000-CO-090	2
79,60-90,59	4555-MC-100	4001-CH-085	hex 46	4001-AC-185	4001-AC-285	4001-AC-385	2000-CO-090	2
90,60-100,59	4555-MC-110	4001-CH-085	hex 46	4001-AC-185	4001-AC-285	4001-AC-385	2000-CO-090	2

Cylindrical shank - SHORT SERIES - without flat from Ø 17,60 to 100,59 mm

Series 4550A
through holes
with radial through
tool coolant

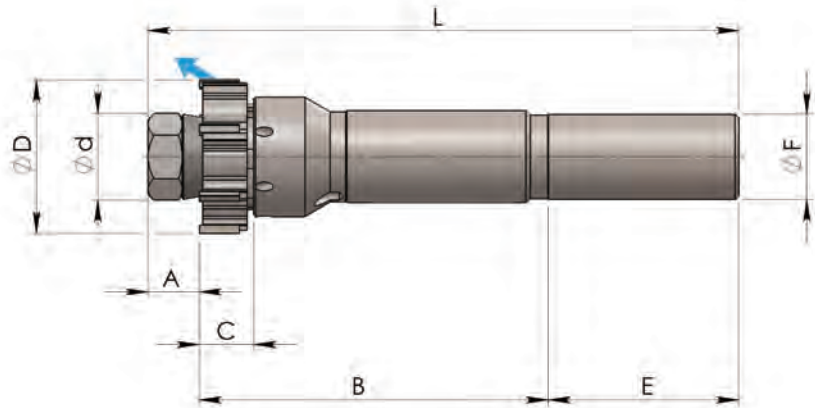

Ø D mm	Ø d mm	A mm	L mm	B mm	C mm	E mm	Ø F ^{h7} mm	Number of teeth
17,60-21,59	12	11	142	81	11	50	20	6
21,60-25,59	12	11	142	81	12	50	20	6
25,60-32,59	15,6	11	163	102	14	50	20	6
32,60-40,59	22	14	172	102	16	56	25	6
40,60-45,59	25,4	15	173	102	16	56	25	6
45,60-60,59	30	20,5	185,5	105	18,5	60	32	6
60,60-79,59	40	24,5	189,5	105	18,5	60	32	6
79,60-100,59	56	28,5	203,5	105	18,5	70	40	8

SPARE PARTS

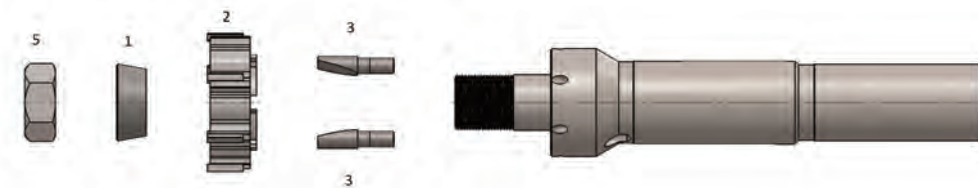

2= Cutting Ring

Ø D mm	Complete mandrel without cutting ring	Conical ring 1	Ring nut or nut 5	Wrench	Drive pin 3	Number of drive pin
17,60-21,59	4550A-MC-010	2010-AC-010	2000-DA-010	hex 10	2000-CO-010	3
21,60-25,59	4550A-MC-020	2010-AC-010	2000-DA-010	hex 10	2000-CO-020	3
25,60-32,59	4550A-MC-030	2010-AC-020	2000-DA-020	hex 13	2000-CO-030	3
32,60-40,59	4550A-MC-040	2010-AC-030	2000-DA-060	hex 19	2000-CO-040	2
40,60-45,59	4550A-MC-050	2010-AC-040	2000-DA-090	hex 22	2000-CO-060	2
45,60-49,59	4550A-MC-060	2010-AC-050	2000-GH-880	hook 30	2000-CO-060	2
49,60-60,59	4550A-MC-070	2010-AC-050	2000-GH-880	hook 30	2000-CO-070	2
60,60-70,59	4550A-MC-080	2010-AC-060	2000-GH-900	hook 40	2000-CO-080	2
70,60-79,59	4550A-MC-090	2010-AC-060	2000-GH-900	hook 40	2000-CO-090	2
79,60-90,59	4550A-MC-100	2010-AC-070	2000-GH-920	hook 56	2000-CO-090	2
90,60-100,59	4550A-MC-110	2010-AC-070	2000-GH-920	hook 56	2000-CO-090	2

Cylindrical shank - SHORT SERIES - without flat from Ø 17,60 to 100,59 mm

**Series 4555A
blind holes
with radial through
tool coolant**

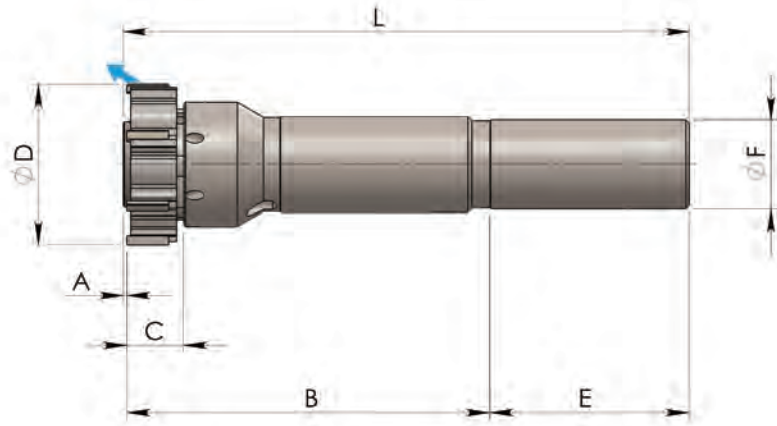

Ø D mm	Ø d mm	A mm	L mm	B mm	C mm	E mm	Ø F ^{h7} mm	Number of teeth
17,60-21,59	11,2	1	132	81	11	50	20	6
21,60-25,59	11,2	1	132	81	12	50	20	6
25,60-32,59	15,1	1	153	102	14	50	20	6
32,60-40,59	20,3	1	159	102	16	56	25	6
40,60-45,59	24,1	1	159	102	16	56	25	6
45,60-60,59	27,9	1,5	166,5	105	18,5	60	32	6
60,60-79,59	37,1	1,5	166,5	105	18,5	60	32	6
79,60-100,59	53,1	1,5	176,5	105	18,5	70	40	8

SPARE PARTS

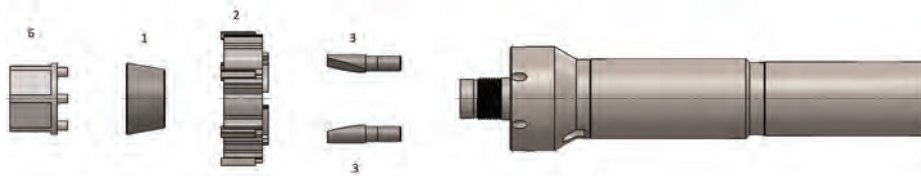

2= Cutting Ring

Ø D mm	Complete mandrel without cutting ring	Key 6	Wrench	Conical ring 1	Conical ring second expansion	Conical ring third expansion	Drive pin 3	Number of drive pin
17,60-21,59	4555A-MC-010	4001-CH-015	hex 10	4001-AC-115	4001-AC-215	-	2000-CO-010	3
21,60-25,59	4555A-MC-020	4001-CH-015	hex 10	4001-AC-115	4001-AC-215	-	2000-CO-020	3
25,60-29,59	4555A-MC-030	4001-CH-025	hex 13	4001-AC-125	4001-AC-225	4001-AC-325	2000-CO-030	3
29,60-32,59	4555A-MC-035	4001-CH-025	hex 13	4001-AC-125	4001-AC-225	4001-AC-325	2000-CO-040	2
32,60-36,59	4555A-MC-040	4001-CH-035	hex 18	4001-AC-135	4001-AC-235	4001-AC-335	2000-CO-040	2
36,60-40,59	4555A-MC-045	4001-CH-035	hex 18	4001-AC-135	4001-AC-235	4001-AC-335	2000-CO-050	2
40,60-45,59	4555A-MC-050	4001-CH-045	hex 22	4001-AC-145	4001-AC-245	4001-AC-345	2000-CO-060	2
45,60-49,59	4555A-MC-060	4001-CH-055	hex 26	4001-AC-155	4001-AC-255	4001-AC-355	2000-CO-060	2
49,60-55,59	4555A-MC-070	4001-CH-055	hex 26	4001-AC-155	4001-AC-255	4001-AC-355	2000-CO-070	2
55,60-60,59	4555A-MC-075	4001-CH-055	hex 26	4001-AC-155	4001-AC-255	4001-AC-355	2000-CO-080	2
60,60-65,59	4555A-MC-080	4001-CH-065	hex 34	4001-AC-165	4001-AC-265	4001-AC-365	2000-CO-080	2
65,60-70,59	4555A-MC-085	4001-CH-065	hex 34	4001-AC-165	4001-AC-265	4001-AC-365	2000-CO-090	2
70,60-79,59	4555A-MC-090	4001-CH-065	hex 34	4001-AC-165	4001-AC-265	4001-AC-365	2000-CO-090	2
79,60-90,59	4555A-MC-100	4001-CH-085	hex 46	4001-AC-185	4001-AC-285	4001-AC-385	2000-CO-090	2
90,60-100,59	4555A-MC-110	4001-CH-085	hex 46	4001-AC-185	4001-AC-285	4001-AC-385	2000-CO-090	2

Cylindrical shank - LONG SERIES - with flat from Ø 17,60 to 100,59 mm

**Series 4500
through holes
with radial through
tool coolant**

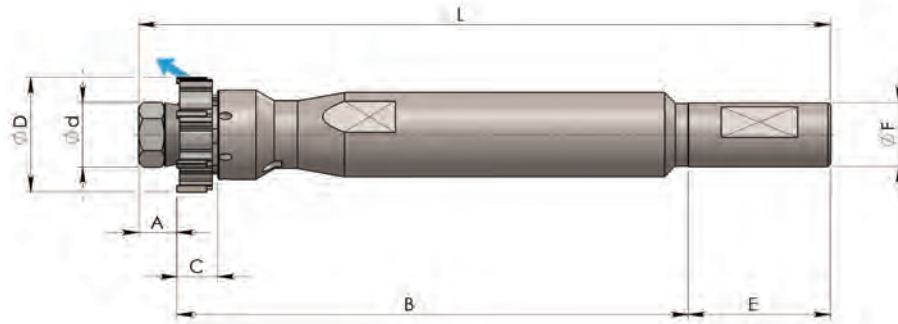

Ø D mm	Ø d mm	A mm	L mm	B mm	C mm	E mm	Ø F ^{h7} mm	Number of teeth
17,60-21,59	12	11	182	121	11	50	20	6
21,60-25,59	12	11	182	121	12	50	20	6
25,60-32,59	15,6	11	214	153	14	50	20	6
32,60-40,59	22	14	249	179	16	56	25	6
40,60-45,59	25,4	15	272	201	16	56	25	6
45,60-60,59	30	20,5	294,5	214	18,5	60	32	6
60,60-79,59	40	24,5	321,5	237	18,5	60	32	6
79,60-100,59	56	28,5	343,5	245	18,5	70	40	8

SPARE PARTS

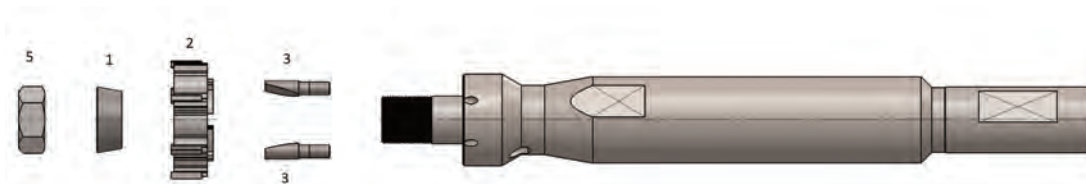

2= Cutting Ring

Ø D mm	Complete mandrel without cutting ring	Conical ring 1	Ring nut or nut 5	Wrench	Drive pin 3	Number of drive pin
17,60-21,59	4500-MC-010	2010-AC-010	2000-DA-010	hex 10	2000-CO-010	3
21,60-25,59	4500-MC-020	2010-AC-010	2000-DA-010	hex 10	2000-CO-020	3
25,60-32,59	4500-MC-030	2010-AC-020	2000-DA-020	hex 13	2000-CO-030	3
32,60-40,59	4500-MC-040	2010-AC-030	2000-DA-060	hex 19	2000-CO-040	2
40,60-45,59	4500-MC-050	2010-AC-040	2000-DA-090	hex 22	2000-CO-060	2
45,60-49,59	4500-MC-060	2010-AC-050	2000-GH-880	hook 30	2000-CO-060	2
49,60-60,59	4500-MC-070	2010-AC-050	2000-GH-880	hook 30	2000-CO-070	2
60,60-70,59	4500-MC-080	2010-AC-060	2000-GH-900	hook 40	2000-CO-080	2
70,60-79,59	4500-MC-090	2010-AC-060	2000-GH-900	hook 40	2000-CO-090	2
79,60-90,59	4500-MC-100	2010-AC-070	2000-GH-920	hook 56	2000-CO-090	2
90,60-100,59	4500-MC-110	2010-AC-070	2000-GH-920	hook 56	2000-CO-090	2

Cylindrical shank - LONG SERIES - with flat from Ø 17,60 to 100,59 mm

Series 4505
blind holes
with radial through
tool coolant

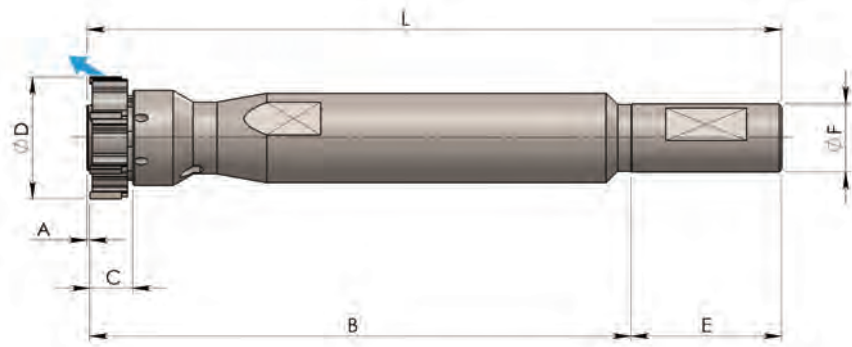

Ø D mm	Ø d mm	A mm	L mm	B mm	C mm	E mm	Ø F ^{h7} mm	Number of teeth
17,60-21,59	11,2	1	172	121	11	50	20	6
21,60-25,59	11,2	1	172	121	12	50	20	6
25,60-32,59	15,1	1	204	153	14	50	20	6
32,60-40,59	20,3	1	236	179	16	56	25	6
40,60-45,59	24,1	1	258	201	16	56	25	6
45,60-60,59	27,9	1,5	275,5	214	18,5	60	32	6
60,60-79,59	37,1	1,5	298,5	237	18,5	60	32	6
79,60-100,59	53,1	1,5	316,5	245	18,5	70	40	8

SPARE PARTS

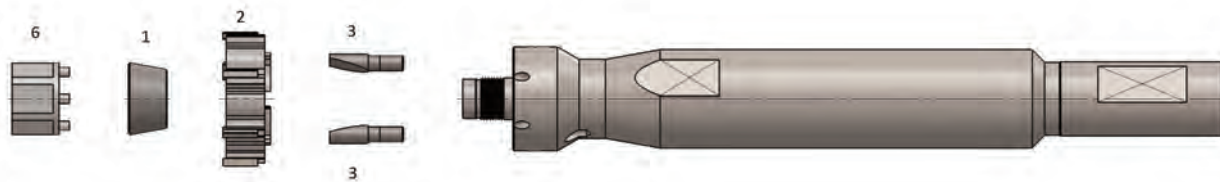

2= Cutting Ring

Ø D mm	Complete mandrel without cutting ring	Key 6	Wrench	Conical ring 1	Conical ring second expansion	Conical ring third expansion	Drive pin 3	Number of drive pin
17,60-21,59	4505-MC-010	4001-CH-015	hex 10	4001-AC-115	4001-AC-215	-	2000-CO-010	3
21,60-25,59	4505-MC-020	4001-CH-015	hex 10	4001-AC-115	4001-AC-215	-	2000-CO-020	3
25,60-29,59	4505-MC-030	4001-CH-025	hex 13	4001-AC-125	4001-AC-225	4001-AC-325	2000-CO-030	3
29,60-32,59	4505-MC-035	4001-CH-025	hex 13	4001-AC-125	4001-AC-225	4001-AC-325	2000-CO-040	2
32,60-36,59	4505-MC-040	4001-CH-035	hex 18	4001-AC-135	4001-AC-235	4001-AC-335	2000-CO-040	2
36,60-40,59	4505-MC-045	4001-CH-035	hex 18	4001-AC-135	4001-AC-235	4001-AC-335	2000-CO-050	2
40,60-45,59	4505-MC-050	4001-CH-045	hex 22	4001-AC-145	4001-AC-245	4001-AC-345	2000-CO-060	2
45,60-49,59	4505-MC-060	4001-CH-055	hex 26	4001-AC-155	4001-AC-255	4001-AC-355	2000-CO-060	2
49,60-55,59	4505-MC-070	4001-CH-055	hex 26	4001-AC-155	4001-AC-255	4001-AC-355	2000-CO-070	2
55,60-60,59	4505-MC-075	4001-CH-055	hex 26	4001-AC-155	4001-AC-255	4001-AC-355	2000-CO-080	2
60,60-65,59	4505-MC-080	4001-CH-065	hex 34	4001-AC-165	4001-AC-265	4001-AC-365	2000-CO-080	2
65,60-70,59	4505-MC-085	4001-CH-065	hex 34	4001-AC-165	4001-AC-265	4001-AC-365	2000-CO-090	2
70,60-79,59	4505-MC-090	4001-CH-065	hex 34	4001-AC-165	4001-AC-265	4001-AC-365	2000-CO-090	2
79,60-90,59	4505-MC-100	4001-CH-085	hex 46	4001-AC-185	4001-AC-285	4001-AC-385	2000-CO-090	2
90,60-100,59	4505-MC-110	4001-CH-085	hex 46	4001-AC-185	4001-AC-285	4001-AC-385	2000-CO-090	2

Cylindrical shank - LONG SERIES - without flat from Ø 17,60 to 100,59 mm

Series 4500A
through holes
with radial through
tool coolant

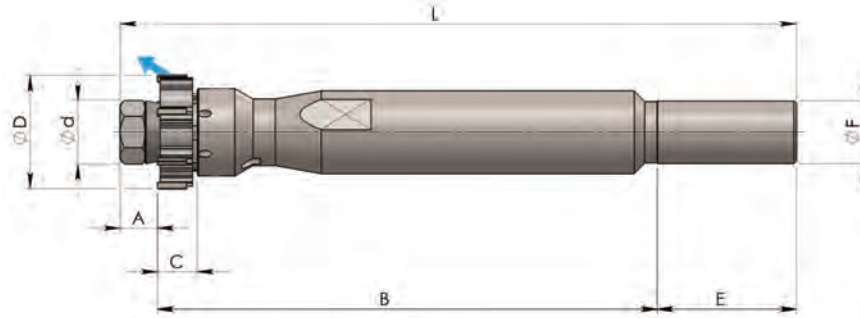

Ø D mm	Ø d mm	A mm	L mm	B mm	C mm	E mm	Ø F ^{h7} mm	Number of teeth
17,60-21,59	12	11	182	121	11	50	20	6
21,60-25,59	12	11	182	121	12	50	20	6
25,60-32,59	15,6	11	214	153	14	50	20	6
32,60-40,59	22	14	249	179	16	56	25	6
40,60-45,59	25,4	15	272	201	16	56	25	6
45,60-60,59	30	20,5	294,5	214	18,5	60	32	6
60,60-79,59	40	24,5	321,5	237	18,5	60	32	6
79,60-100,59	56	28,5	343,5	245	18,5	70	40	8

SPARE PARTS

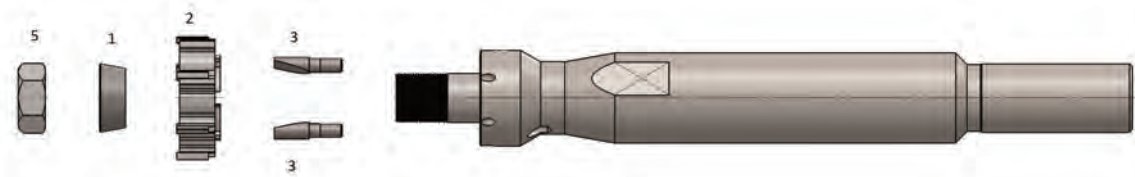

2= Cutting Ring

Ø D mm	Complete mandrel without cutting ring	Conical ring 1	Ring nut or nut 5	Wrench	Drive pin 3	Number of drive pin
17,60-21,59	4500A-MC-010	2010-AC-010	2000-DA-010	hex 10	2000-CO-010	3
21,60-25,59	4500A-MC-020	2010-AC-010	2000-DA-010	hex 10	2000-CO-020	3
25,60-32,59	4500A-MC-030	2010-AC-020	2000-DA-020	hex 13	2000-CO-030	3
32,60-40,59	4500A-MC-040	2010-AC-030	2000-DA-060	hex 19	2000-CO-040	2
40,60-45,59	4500A-MC-050	2010-AC-040	2000-DA-090	hex 22	2000-CO-060	2
45,60-49,59	4500A-MC-060	2010-AC-050	2000-GH-880	hook 30	2000-CO-060	2
49,60-60,59	4500A-MC-070	2010-AC-050	2000-GH-880	hook 30	2000-CO-070	2
60,60-70,59	4500A-MC-080	2010-AC-060	2000-GH-900	hook 40	2000-CO-080	2
70,60-79,59	4500A-MC-090	2010-AC-060	2000-GH-900	hook 40	2000-CO-090	2
79,60-90,59	4500A-MC-100	2010-AC-070	2000-GH-920	hook 56	2000-CO-090	2
90,60-100,59	4500A-MC-110	2010-AC-070	2000-GH-920	hook 56	2000-CO-090	2

Cylindrical shank - LONG SERIES - without flat from Ø 17,60 to 100,59 mm

**Series 4505A
blind holes
with radial through
tool coolant**

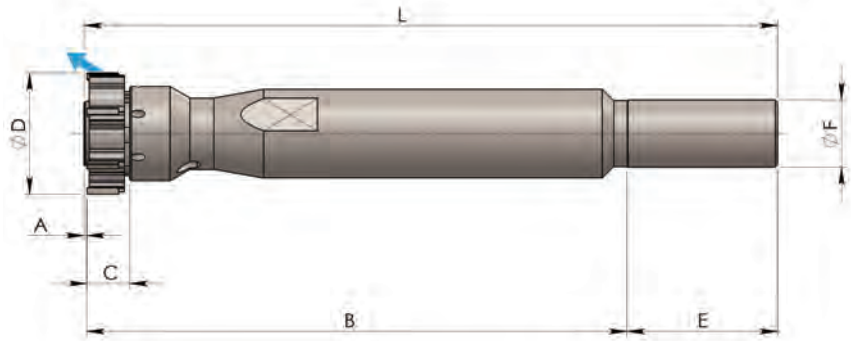

Ø D mm	Ø d mm	A mm	L mm	B mm	C mm	E mm	Ø F ^{h7} mm	Number of teeth
17,60-21,59	11,2	1	172	121	11	50	20	6
21,60-25,59	11,2	1	172	121	12	50	20	6
25,60-32,59	15,1	1	204	153	14	50	20	6
32,60-40,59	20,3	1	236	179	16	56	25	6
40,60-45,59	24,1	1	258	201	16	56	25	6
45,60-60,59	27,9	1,5	275,5	214	18,5	60	32	6
60,60-79,59	37,1	1,5	298,5	237	18,5	60	32	6
79,60-100,59	53,1	1,5	316,5	245	18,5	70	40	8

SPARE PARTS

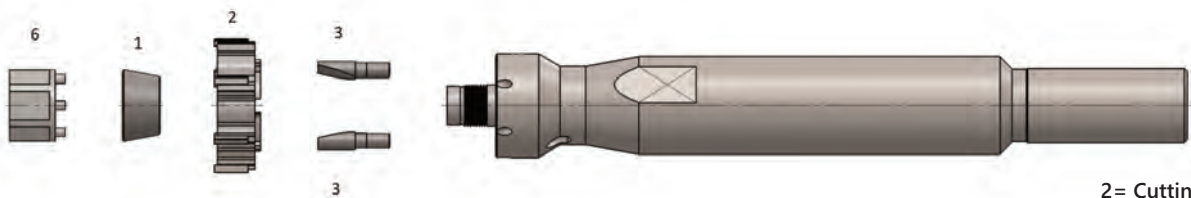

2= Cutting Ring

Ø D mm	Complete mandrel without cutting ring	Key 6	Wrench	Conical ring 1	Conical ring second expansion	Conical ring third expansion	Drive pin 3	Number of drive pin
17,60-21,59	4505A-MC-010	4001-CH-015	hex 10	4001-AC-115	4001-AC-215	-	2000-CO-010	3
21,60-25,59	4505A-MC-020	4001-CH-015	hex 10	4001-AC-115	4001-AC-215	-	2000-CO-020	3
25,60-29,59	4505A-MC-030	4001-CH-025	hex 13	4001-AC-125	4001-AC-225	4001-AC-325	2000-CO-030	3
29,60-32,59	4505A-MC-035	4001-CH-025	hex 13	4001-AC-125	4001-AC-225	4001-AC-325	2000-CO-040	2
32,60-36,59	4505A-MC-040	4001-CH-035	hex 18	4001-AC-135	4001-AC-235	4001-AC-335	2000-CO-040	2
36,60-40,59	4505A-MC-045	4001-CH-035	hex 18	4001-AC-135	4001-AC-235	4001-AC-335	2000-CO-050	2
40,60-45,59	4505A-MC-050	4001-CH-045	hex 22	4001-AC-145	4001-AC-245	4001-AC-345	2000-CO-060	2
45,60-49,59	4505A-MC-060	4001-CH-055	hex 26	4001-AC-155	4001-AC-255	4001-AC-355	2000-CO-060	2
49,60-55,59	4505A-MC-070	4001-CH-055	hex 26	4001-AC-155	4001-AC-255	4001-AC-355	2000-CO-070	2
55,60-60,59	4505A-MC-075	4001-CH-055	hex 26	4001-AC-155	4001-AC-255	4001-AC-355	2000-CO-080	2
60,60-65,59	4505A-MC-080	4001-CH-065	hex 34	4001-AC-165	4001-AC-265	4001-AC-365	2000-CO-080	2
65,60-70,59	4505A-MC-085	4001-CH-065	hex 34	4001-AC-165	4001-AC-265	4001-AC-365	2000-CO-090	2
70,60-79,59	4505A-MC-090	4001-CH-065	hex 34	4001-AC-165	4001-AC-265	4001-AC-365	2000-CO-090	2
79,60-90,59	4505A-MC-100	4001-CH-085	hex 46	4001-AC-185	4001-AC-285	4001-AC-385	2000-CO-090	2
90,60-100,59	4505A-MC-110	4001-CH-085	hex 46	4001-AC-185	4001-AC-285	4001-AC-385	2000-CO-090	2

Modular Composit shank - SHORT SERIES from Ø 17,60 to 100,59 mm

Series 4330
through holes
with radial through
tool coolant

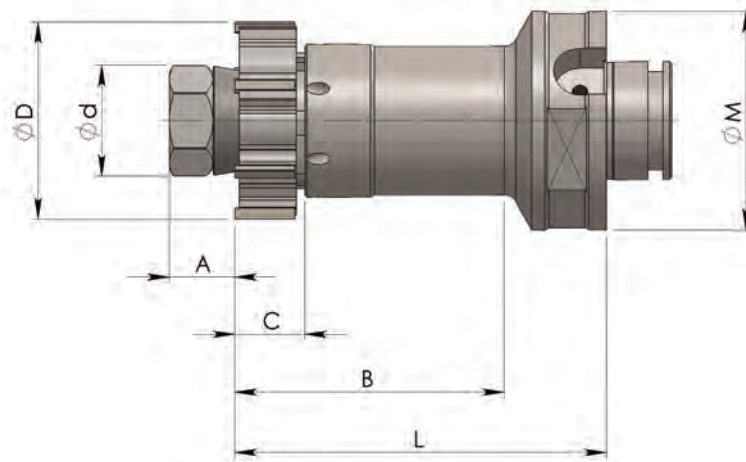

Ø D mm	Ø d mm	A mm	B mm	L mm	C mm	Mod. shank Ø M	Number of teeth
17,60-21,59	12	11	55	75	11	50	6
21,60-25,59	12	11	55	75	12	50	6
25,60-32,59	15,6	11	60	80	14	50	6
32,60-40,59	22	14	60	80	16	50	6
40,60-45,59	25,4	15	60	80	16	50	6
45,60-60,59	30	20,5	60	80	18,5	50	6
60,60-79,59	40	24,5	65	90	18,5	63	6
79,60-100,59	56	28,5	65	90	18,5	63	8

SPARE PARTS

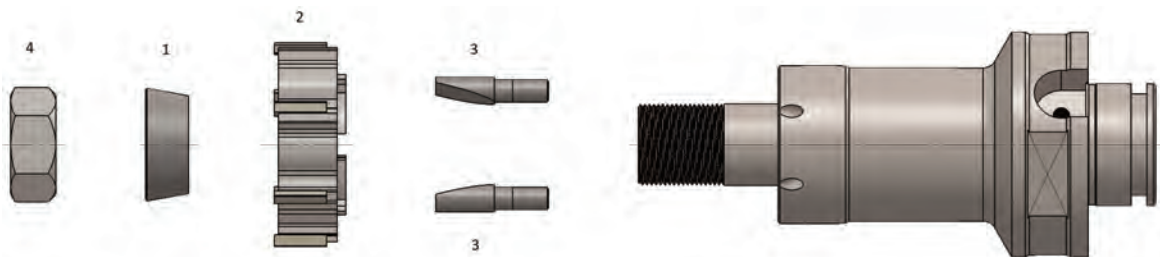

2= Cutting Ring

Ø D mm	Complete mandrel without cutting ring	Conical ring 1	Ring nut or nut 4	Wrench	Drive pin 3	Number of drive pin
17,60-21,59	4330-MC-010	2010-AC-010	2000-DA-010	hex 10	2000-CO-010	3
21,60-25,59	4330-MC-020	2010-AC-010	2000-DA-010	hex 10	2000-CO-020	3
25,60-32,59	4330-MC-030	2010-AC-020	2000-DA-020	hex 13	2000-CO-030	3
32,60-40,59	4330-MC-040	2010-AC-030	2000-DA-060	hex 19	2000-CO-040	2
40,60-45,59	4330-MC-050	2010-AC-040	2000-DA-090	hex 22	2000-CO-060	2
45,60-49,59	4330-MC-060	2010-AC-050	2000-GH-880	hook 30	2000-CO-060	2
49,60-60,59	4330-MC-070	2010-AC-050	2000-GH-880	hook 30	2000-CO-070	2
60,60-70,59	4330-MC-080	2010-AC-060	2000-GH-900	hook 40	2000-CO-080	2
70,60-79,59	4330-MC-090	2010-AC-060	2000-GH-900	hook 40	2000-CO-090	2
79,60-90,59	4330-MC-100	2010-AC-070	2000-GH-920	hook 56	2000-CO-090	2
90,60-100,59	4330-MC-110	2010-AC-070	2000-GH-920	hook 56	2000-CO-090	2

Modular Composit shank - SHORT SERIES from Ø 17,60 to 100,59 mm

Series 4335
blind holes
with radial through
tool coolant

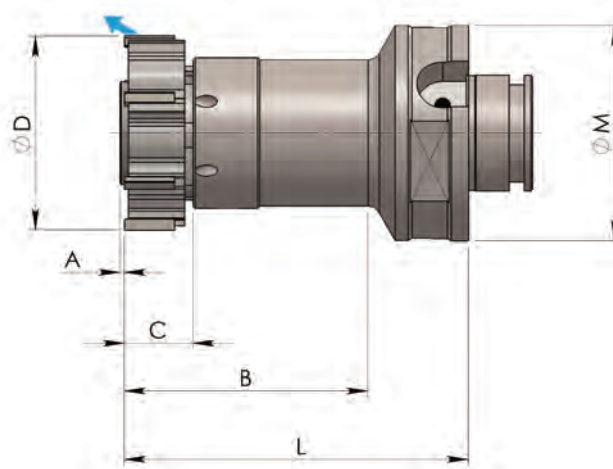

Ø D mm	Ø d mm	A mm	B mm	L mm	C mm	Mod. shank Ø M	Number of teeth
17,60-21,59	11,2	1	55	75	11	50	6
21,60-25,59	11,2	1	55	75	12	50	6
25,60-32,59	15,1	1	60	80	14	50	6
32,60-40,59	20,3	1	60	80	16	50	6
40,60-45,59	24,1	1	60	80	16	50	6
45,60-60,59	27,9	1,5	60	80	18,5	50	6
60,60-79,59	37,1	1,5	65	90	18,5	63	6
79,60-100,59	53,1	1,5	65	90	18,5	63	8

SPARE PARTS

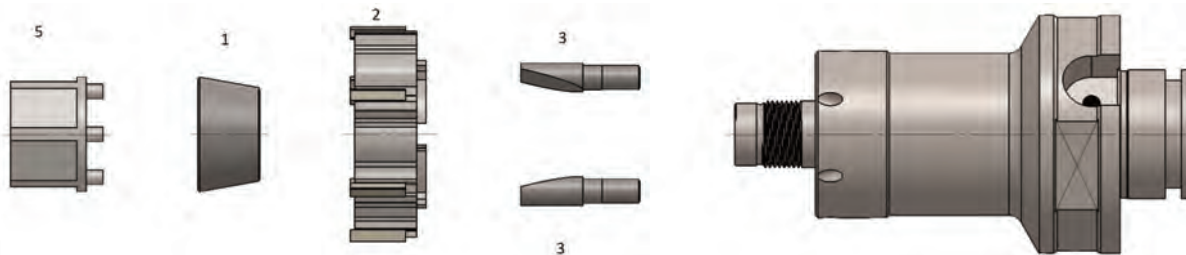

2= Cutting Ring

Ø D mm	Complete mandrel without cutting ring	Key 5	Wrench	Conical ring 1	Conical ring second expansion	Conical ring third expansion	Drive pin 3	Number of drive pin
17,60-21,59	4335-MC-010	4001-CH-015	hex 10	4001-AC-115	4001-AC-215	-	2000-CO-010	3
21,60-25,59	4335-MC-020	4001-CH-015	hex 10	4001-AC-115	4001-AC-215	-	2000-CO-020	3
25,60-29,59	4335-MC-030	4001-CH-025	hex 13	4001-AC-125	4001-AC-225	4001-AC-325	2000-CO-030	3
29,60-32,59	4335-MC-035	4001-CH-025	hex 13	4001-AC-125	4001-AC-225	4001-AC-325	2000-CO-040	2
32,60-36,59	4335-MC-040	4001-CH-035	hex 18	4001-AC-135	4001-AC-235	4001-AC-335	2000-CO-040	2
36,60-40,59	4335-MC-045	4001-CH-035	hex 18	4001-AC-135	4001-AC-235	4001-AC-335	2000-CO-050	2
40,60-45,59	4335-MC-050	4001-CH-045	hex 22	4001-AC-145	4001-AC-245	4001-AC-345	2000-CO-060	2
45,60-49,59	4335-MC-060	4001-CH-055	hex 26	4001-AC-155	4001-AC-255	4001-AC-355	2000-CO-060	2
49,60-55,59	4335-MC-070	4001-CH-055	hex 26	4001-AC-155	4001-AC-255	4001-AC-355	2000-CO-070	2
55,60-60,59	4335-MC-075	4001-CH-055	hex 26	4001-AC-155	4001-AC-255	4001-AC-355	2000-CO-080	2
60,60-65,59	4335-MC-080	4001-CH-065	hex 34	4001-AC-165	4001-AC-265	4001-AC-365	2000-CO-080	2
65,60-70,59	4335-MC-085	4001-CH-065	hex 34	4001-AC-165	4001-AC-265	4001-AC-365	2000-CO-090	2
70,60-79,59	4335-MC-090	4001-CH-065	hex 34	4001-AC-165	4001-AC-265	4001-AC-365	2000-CO-090	2
79,60-90,59	4335-MC-100	4001-CH-085	hex 46	4001-AC-185	4001-AC-285	4001-AC-385	2000-CO-090	2
90,60-100,59	4335-MC-110	4001-CH-085	hex 46	4001-AC-185	4001-AC-285	4001-AC-385	2000-CO-090	2

Modular Composit shank - STANDARD SERIES from Ø 17,60 to 100,59 mm

Series 4350
through holes
with radial through
tool coolant
Ø 17,60÷100,59 mm

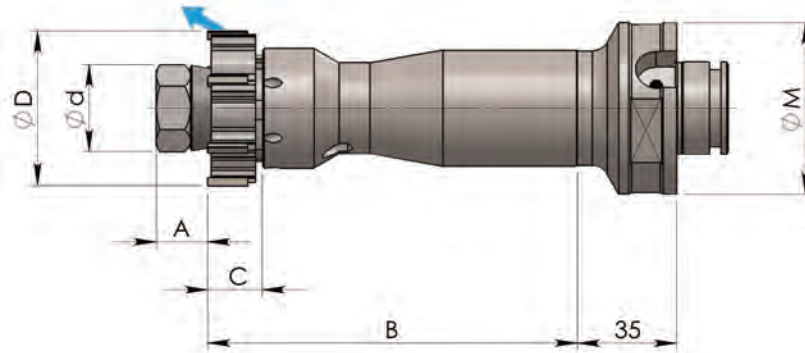

Ø D mm	Ø d mm	A mm	B mm	C mm	Mod. shank Ø M	Number of teeth
17,60 - 21,59	12	11	81	11	50	6
21,60 - 25,59	12	11	81	12	50	6
25,60 - 32,59	15,6	11	102	14	50	6
32,60 - 40,59	22	14	102	16	50	6
40,60 - 45,59	25,4	15	102	16	50	6
45,60 - 60,59	30	20,5	105	18,5	50	6
60,60 - 79,59	40	24,5	105	18,5	63	6
79,60 - 100,59	56	28,5	105	18,5	63	8

SPARE PARTS

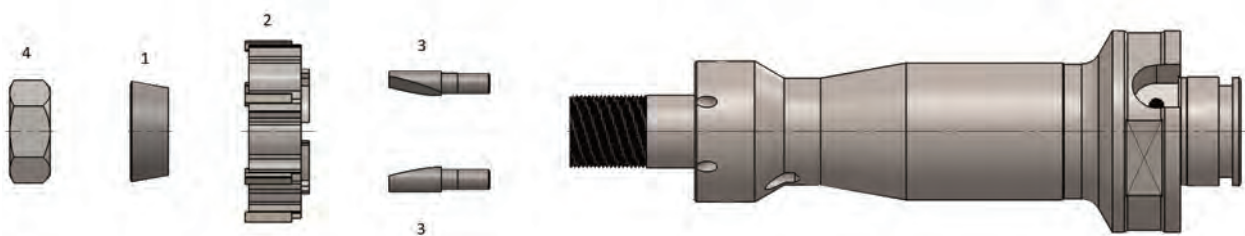

2= Cutting Ring

Ø D mm	Complete Mandrel without cutting ring	Conical ring 1	Ring nut or nut 4	Wrench	Drive pin 3	Number of drive pin
17,60-21,59	4350-MC-010	2010-AC-010	2000-DA-010	hex 10	2000-CO-010	3
21,60-25,59	4350-MC-020	2010-AC-010	2000-DA-010	hex 10	2000-CO-020	3
25,60-32,59	4350-MC-030	2010-AC-020	2000-DA-020	hex 13	2000-CO-030	3
32,60-40,59	4350-MC-040	2010-AC-030	2000-DA-060	hex 19	2000-CO-040	2
40,60-45,59	4350-MC-050	2010-AC-040	2000-DA-090	hex 22	2000-CO-060	2
45,60-49,59	4350-MC-060	2010-AC-050	2000-GH-880	hook 30	2000-CO-060	2
49,60-60,59	4350-MC-070	2010-AC-050	2000-GH-880	hook 30	2000-CO-070	2
60,60-70,59	4350-MC-080	2010-AC-060	2000-GH-900	hook 40	2000-CO-080	2
70,60-79,59	4350-MC-090	2010-AC-060	2000-GH-900	hook 40	2000-CO-090	2
79,60-90,59	4350-MC-100	2010-AC-070	2000-GH-920	hook 56	2000-CO-090	2
90,60-100,59	4350-MC-110	2010-AC-070	2000-GH-920	hook 56	2000-CO-090	2

Modular Composit shank - STANDARD SERIES from Ø 17,60 to 100,59 mm

Series 4355
blind holes
with radial through
tool coolant
Ø 17,60 ÷ 100,59

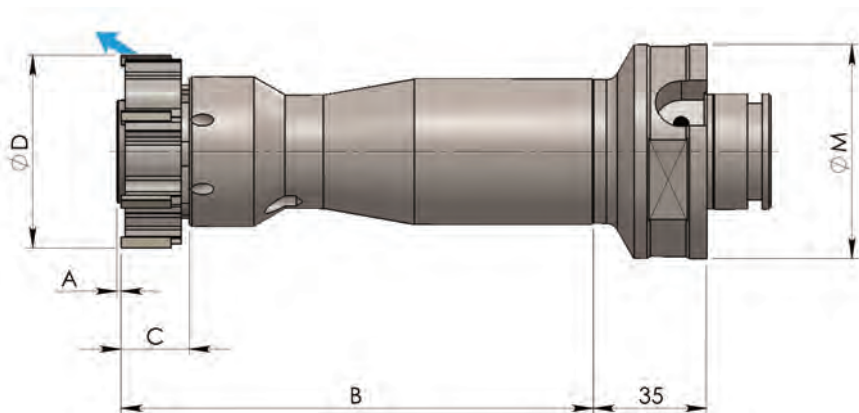

Ø D mm	Ø d mm	A mm	B mm	C mm	Mod.shank Ø M	Number of teeth
17,60 - 21,59	11,2	1	81	11	50	6
21,60 - 25,59	11,2	1	81	12	50	6
25,60 - 32,59	15,1	1	102	14	50	6
32,60 - 40,59	20,3	1	102	16	50	6
40,60 - 45,59	24,1	1	102	16	50	6
45,60 - 60,59	27,9	1,5	105	18,5	50	6
60,60 - 79,59	37,1	1,5	105	18,5	63	6
79,60 - 100,59	53,1	1,5	105	18,5	63	8

SPARE PARTS

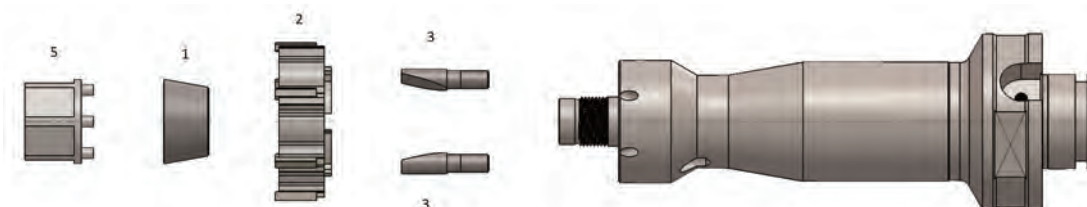

2= Cutting Ring

Ø D mm	Complete Mandrel without cutting ring	key 5	Wrench	Conical ring 1	Conical ring second expansion	Conical ring third expansion	Drive pin 3	Number of drive pin
17,60-21,59	4355-MC-010	4001-CH-015	hex 10	4001-AC-115	4001-AC-215	-	2000-CO-010	3
21,60-25,59	4355-MC-020	4001-CH-015	hex 10	4001-AC-115	4001-AC-215	-	2000-CO-020	3
25,60-29,59	4355-MC-030	4001-CH-025	hex 13	4001-AC-125	4001-AC-225	4001-AC-325	2000-CO-030	3
29,60-32,59	4355-MC-035	4001-CH-025	hex 13	4001-AC-125	4001-AC-225	4001-AC-325	2000-CO-040	2
32,60-36,59	4355-MC-040	4001-CH-035	hex 18	4001-AC-135	4001-AC-235	4001-AC-335	2000-CO-040	2
36,60-40,59	4355-MC-045	4001-CH-035	hex 18	4001-AC-135	4001-AC-235	4001-AC-335	2000-CO-050	2
40,60-45,59	4355-MC-050	4001-CH-045	hex 22	4001-AC-145	4001-AC-245	4001-AC-345	2000-CO-060	2
45,60-49,59	4355-MC-060	4001-CH-055	hex 26	4001-AC-155	4001-AC-255	4001-AC-355	2000-CO-060	2
49,60-55,59	4355-MC-070	4001-CH-055	hex 26	4001-AC-155	4001-AC-255	4001-AC-355	2000-CO-070	2
55,60-60,59	4355-MC-075	4001-CH-055	hex 26	4001-AC-155	4001-AC-255	4001-AC-355	2000-CO-080	2
60,60-65,59	4355-MC-080	4001-CH-065	hex 34	4001-AC-165	4001-AC-265	4001-AC-365	2000-CO-080	2
65,60-70,59	4355-MC-085	4001-CH-065	hex 34	4001-AC-165	4001-AC-265	4001-AC-365	2000-CO-090	2
70,60-79,59	4355-MC-090	4001-CH-065	hex 34	4001-AC-165	4001-AC-265	4001-AC-365	2000-CO-090	2
79,60-90,59	4355-MC-100	4001-CH-085	hex 46	4001-AC-185	4001-AC-285	4001-AC-385	2000-CO-090	2
90,60-100,59	4355-MC-110	4001-CH-085	hex 46	4001-AC-185	4001-AC-285	4001-AC-385	2000-CO-090	2

Modular Composit shank - STANDARD SERIES from Ø 100,60 to 200,59 mm

Series 4350
through holes
with radial through
tool coolant
Ø 100,60÷200,59 mm

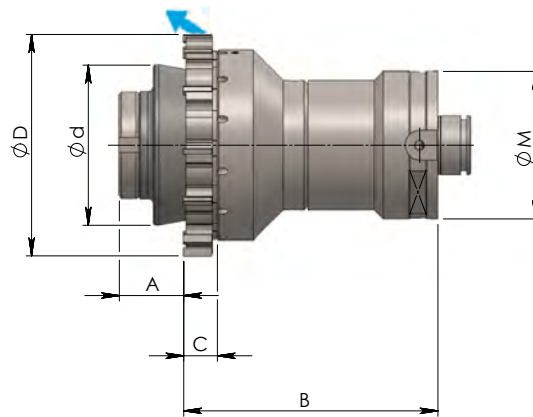

Ø D mm	Ø d mm	A mm	B mm	C mm	Mod. shank Ø M	Number of teeth
100,60 - 110,59	73,8	35,5	140	18,5	80	10
110,60 - 115,59	80,8	35,5	140	18,5	80	12
115,60 - 125,59	86,8	35,5	140	18,5	80	12
125,60 - 139,59	90,8	35,5	140	18,5	80	12
139,60 - 145,59	102,8	35,5	140	18,5	80	12
145,60 - 155,59	107,8	35,5	140	18,5	80	12
155,60 - 165,59	107,8	48,5	140	18,5	80	12
165,60 - 175,59	117,8	48,5	140	18,5	80	12
175,60 - 185,59	127,8	48,5	140	18,5	80	12
185,60 - 195,59	137,8	48,5	140	18,5	80	12
195,60 - 200,59	145,8	48,5	140	18,5	80	12

SPARE PARTS

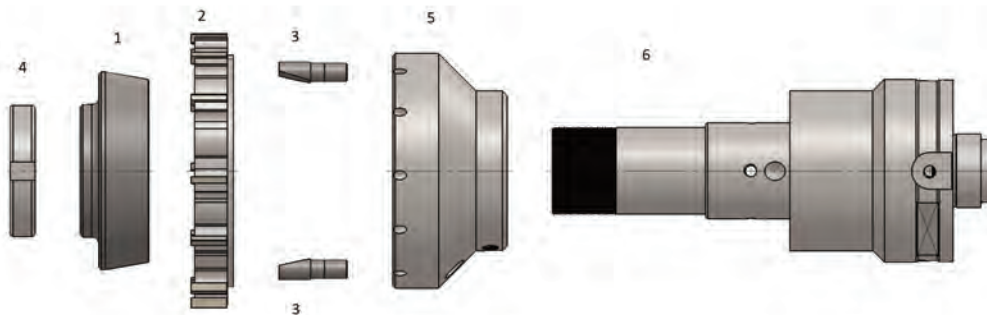

2= Cutting Ring

Ø D mm	Complete Mandrel without cutting ring	Conical ring 1	Nut 4	Wrench	Flange 5	Mandrel 6	Drive pin 3	Number of drive pin
100,60-110,59	4350-MC-120	2060-BU-010	2000-GH-095	hook 58	4355-FL-035	4350-MA-120	2000-CO-090	2
110,60-115,59	4350-MC-130	2060-BU-020	2000-GH-095	hook 58	4355-FL-045	4350-MA-120	2000-CO-090	2
115,60-120,59	4350-MC-140	2060-BU-030	2000-GH-095	hook 58	4355-FL-055	4350-MA-120	2000-CO-090	2
120,60-125,59	4350-MC-150	2060-BU-030	2000-GH-095	hook 58	4355-FL-065	4350-MA-120	2000-CO-090	2
125,60-132,59	4350-MC-160	2060-BU-040	2000-GH-095	hook 58	4355-FL-075	4350-MA-120	2000-CO-100	2
132,60-139,59	4350-MC-170	2060-BU-040	2000-GH-095	hook 58	4355-FL-085	4350-MA-120	2000-CO-100	2
139,60-145,59	4350-MC-180	2060-BU-050	2000-GH-095	hook 58	4355-FL-095	4350-MA-120	2000-CO-100	2
145,60-155,59	4350-MC-190	2060-BU-060	2000-GH-095	hook 58	4355-FL-105	4350-MA-120	2000-CO-110	2
155,60-165,59	4350-MC-200	2060-BU-070	2000-GH-120	hook 90	4355-FL-115	4350-MA-200	2000-CO-110	2
165,60-175,59	4350-MC-210	2060-BU-080	2000-GH-120	hook 90	4355-FL-125	4350-MA-200	2000-CO-110	2
175,60-185,59	4350-MC-220	2060-BU-090	2000-GH-120	hook 90	4355-FL-135	4350-MA-200	2000-CO-120	2
185,60-195,59	4350-MC-230	2060-BU-100	2000-GH-120	hook 90	4355-FL-145	4350-MA-200	2000-CO-120	2
195,60-200,59	4350-MC-240	2060-BU-110	2000-GH-120	hook 90	4355-FL-155	4350-MA-200	2000-CO-120	2

Modular Composit shank - STANDARD SERIES from Ø 100,60 to 200,59 mm

Series 4355
blind holes with
radial and central
through tool coolant
Ø 100,60 ÷ 200,59 mm

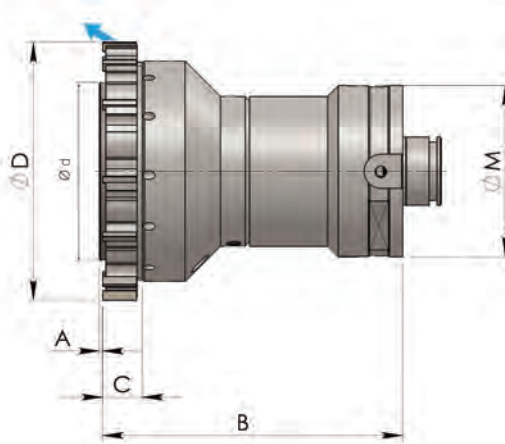

Ø D mm	Ø d mm	A mm	B mm	C mm	Mod. shank Ø M	Number of teeth
100,60 - 110,59	70,3	1,5	140	18,5	80	10
110,60 - 115,59	76,3	1,5	140	18,5	80	12
115,60 - 125,59	83,3	1,5	140	18,5	80	12
125,60 - 139,59	87,3	1,5	140	18,5	80	12
139,60 - 145,59	99,3	1,5	140	18,5	80	12
145,60 - 155,59	104,3	1,5	140	18,5	80	12
155,60 - 165,59	104,3	1,5	140	18,5	80	12
165,60 - 175,59	114,3	1,5	140	18,5	80	12
175,60 - 185,59	124,3	1,5	140	18,5	80	12
185,60 - 195,59	134,3	1,5	140	18,5	80	12
195,60 - 200,59	142,3	1,5	140	18,5	80	12

SPARE PARTS

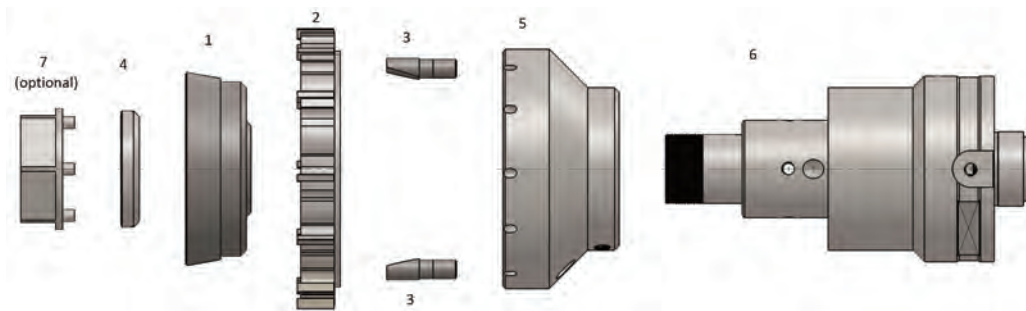

2= Cutting Ring

Ø D mm	Complete Mandrel without cutting ring	Conical ring 1	Nut 4	Wrench	Flange 5	Mandrel 6	Key (optional) 7	Drive pin 3	Number of drive pin
100,60-110,59	4355-MC-120	4001-AC-116	4001-GH-035	hex 46	4355-FL-035	4355-MA-120	4001-CH-135	2000-CO-090	2
110,60-115,59	4355-MC-130	4001-AC-126	4001-GH-035	hex 46	4355-FL-045	4355-MA-120	4001-CH-135	2000-CO-090	2
115,60-120,59	4355-MC-140	4001-AC-136	4001-GH-035	hex 46	4355-FL-055	4355-MA-120	4001-CH-135	2000-CO-090	2
120,60-125,59	4355-MC-150	4001-AC-136	4001-GH-035	hex 46	4355-FL-065	4355-MA-120	4001-CH-135	2000-CO-090	2
125,60-132,59	4355-MC-160	4001-AC-146	4001-GH-035	hex 46	4355-FL-075	4355-MA-120	4001-CH-135	2000-CO-100	2
132,60-139,59	4355-MC-170	4001-AC-146	4001-GH-035	hex 46	4355-FL-085	4355-MA-120	4001-CH-135	2000-CO-100	2
139,60-145,59	4355-MC-180	4001-AC-156	4001-GH-035	hex 46	4355-FL-095	4355-MA-120	4001-CH-135	2000-CO-100	2
145,60-155,59	4355-MC-190	4001-AC-166	4001-GH-035	hex 46	4355-FL-105	4355-MA-120	4001-CH-135	2000-CO-110	2
155,60-165,59	4355-MC-200	4001-AC-176	4001-GH-115	hex 46	4355-FL-115	4355-MA-200	4001-CH-115	2000-CO-110	2
165,60-175,59	4355-MC-210	4001-AC-186	4001-GH-115	hex 46	4355-FL-125	4355-MA-200	4001-CH-115	2000-CO-110	2
175,60-185,59	4355-MC-220	4001-AC-196	4001-GH-115	hex 46	4355-FL-135	4355-MA-200	4001-CH-115	2000-CO-120	2
185,60-195,59	4355-MC-230	4001-AC-117	4001-GH-115	hex 46	4355-FL-145	4355-MA-200	4001-CH-115	2000-CO-120	2
195,60-200,59	4355-MC-240	4001-AC-127	4001-GH-115	hex 46	4355-FL-155	4355-MA-200	4001-CH-115	2000-CO-120	2

Conical ring for second and third expansions are available on request.

Modular Composit shank - LONG SERIES from Ø 17,60 to 100,59 mm

Series 4300
through holes
with radial through
tool coolant

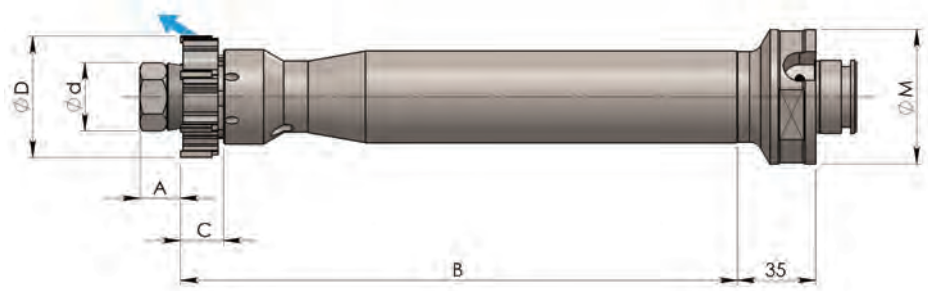

Ø D mm	Ø d mm	A mm	B mm	C mm	Mod. shank Ø M	Number of teeth
17,60-21,59	12	11	121	11	50	6
21,60-25,59	12	11	121	12	50	6
25,60-32,59	15,6	11	153	14	50	6
32,60-40,59	22	14	179	16	50	6
40,60-45,59	25,4	15	201	16	50	6
45,60-60,59	30	20,5	214	18,5	50	6
60,60-79,59	40	24,5	237	18,5	63	6
79,60-100,59	56	28,5	245	18,5	63	8

SPARE PARTS

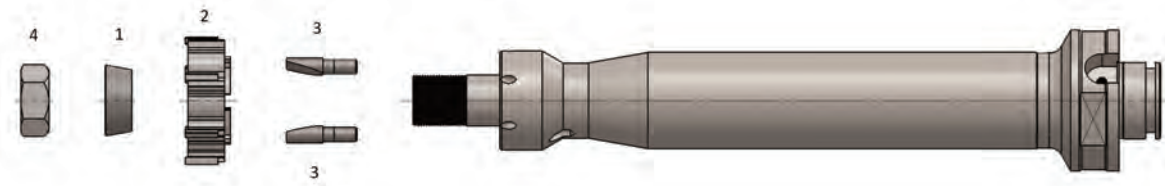

2= Cutting Ring

Ø D mm	Complete mandrel without cutting ring	Conical ring 1	Ring nut or nut 4	Wrench	Drive pin 3	Number of drive pin
17,60-21,59	4300-MC-010	2010-AC-010	2000-DA-010	hex 10	2000-CO-010	3
21,60-25,59	4300-MC-020	2010-AC-010	2000-DA-010	hex 10	2000-CO-020	3
25,60-32,59	4300-MC-030	2010-AC-020	2000-DA-020	hex 13	2000-CO-030	3
32,60-40,59	4300-MC-040	2010-AC-030	2000-DA-060	hex 19	2000-CO-040	2
40,60-45,59	4300-MC-050	2010-AC-040	2000-DA-090	hex 22	2000-CO-060	2
45,60-49,59	4300-MC-060	2010-AC-050	2000-GH-880	hook 30	2000-CO-060	2
49,60-60,59	4300-MC-070	2010-AC-050	2000-GH-880	hook 30	2000-CO-070	2
60,60-70,59	4300-MC-080	2010-AC-060	2000-GH-900	hook 40	2000-CO-080	2
70,60-79,59	4300-MC-090	2010-AC-060	2000-GH-900	hook 40	2000-CO-090	2
79,60-90,59	4300-MC-100	2010-AC-070	2000-GH-920	hook 56	2000-CO-090	2
90,60-100,59	4300-MC-110	2010-AC-070	2000-GH-920	hook 56	2000-CO-090	2

Modular Composit shank - LONG SERIES from Ø 17,60 to 100,59 mm

**Series 4305
blind holes
with radial holes
through tool coolant**

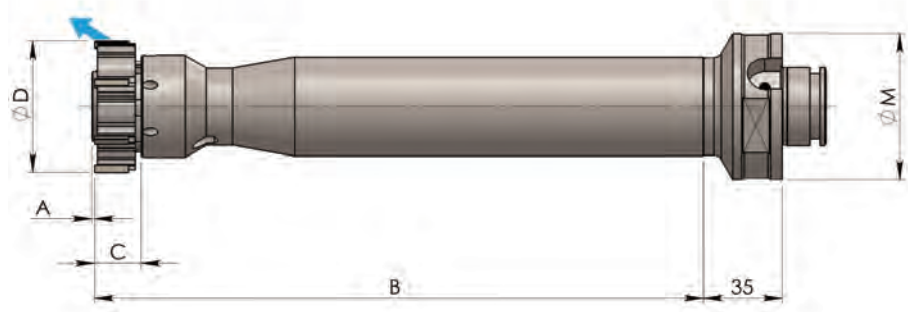

Ø D mm	Ø d mm	A mm	B mm	C mm	Mod. shank Ø M	Number of teeth
17,60-21,59	11,2	1	121	11	50	6
21,60-25,59	11,2	1	121	12	50	6
25,60-32,59	15,1	1	153	14	50	6
32,60-40,59	20,3	1	179	16	50	6
40,60-45,59	24,1	1	201	16	50	6
45,60-60,59	27,9	1,5	214	18,5	50	6
60,60-79,59	37,1	1	237	18,5	63	6
79,60-100,59	53,1	1,5	245	18,5	63	8

SPARE PARTS

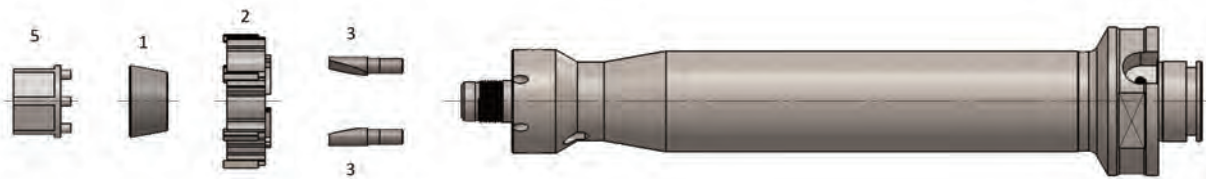

2= Cutting Ring

Ø D mm	Complete Mandrel without cutting ring	key 5	Wrench	Conical ring 1	Conical ring second expansion	Conical ring third expansion	Drive pin 3	Number of drive pin
17,60-21,59	4305-MC-010	4001-CH-015	hex 10	4001-AC-115	4001-AC-215	-	2000-CO-010	3
21,60-25,59	4305-MC-020	4001-CH-015	hex 10	4001-AC-115	4001-AC-215	-	2000-CO-020	3
25,60-29,59	4305-MC-030	4001-CH-025	hex 13	4001-AC-125	4001-AC-225	4001-AC-325	2000-CO-030	3
29,60-32,59	4305-MC-035	4001-CH-025	hex 13	4001-AC-125	4001-AC-225	4001-AC-325	2000-CO-040	2
32,60-36,59	4305-MC-040	4001-CH-035	hex 18	4001-AC-135	4001-AC-235	4001-AC-335	2000-CO-040	2
36,60-40,59	4305-MC-045	4001-CH-035	hex 18	4001-AC-135	4001-AC-235	4001-AC-335	2000-CO-050	2
40,60-45,59	4305-MC-050	4001-CH-045	hex 22	4001-AC-145	4001-AC-245	4001-AC-345	2000-CO-060	2
45,60-49,59	4305-MC-060	4001-CH-055	hex 26	4001-AC-155	4001-AC-255	4001-AC-355	2000-CO-060	2
49,60-55,59	4305-MC-070	4001-CH-055	hex 26	4001-AC-155	4001-AC-255	4001-AC-355	2000-CO-070	2
55,60-60,59	4305-MC-075	4001-CH-055	hex 26	4001-AC-155	4001-AC-255	4001-AC-355	2000-CO-080	2
60,60-65,59	4305-MC-080	4001-CH-065	hex 34	4001-AC-165	4001-AC-265	4001-AC-365	2000-CO-080	2
65,60-70,59	4305-MC-085	4001-CH-065	hex 34	4001-AC-165	4001-AC-265	4001-AC-365	2000-CO-090	2
70,60-79,59	4305-MC-090	4001-CH-065	hex 34	4001-AC-165	4001-AC-265	4001-AC-365	2000-CO-090	2
79,60-90,59	4305-MC-100	4001-CH-085	hex 46	4001-AC-185	4001-AC-285	4001-AC-385	2000-CO-090	2
90,60-100,59	4305-MC-110	4001-CH-085	hex 46	4001-AC-185	4001-AC-285	4001-AC-385	2000-CO-090	2

Interchangeable

Heads



Features & Benefits

- Series: 7000-MC, 7000-ML, 7000-MM
- Diameter range from 11.80 to 80.60 mm.
- Heads are either fixed or expanding for improved productivity.
- Straight, left, or right hand helical flutes making through or blind holes achievable.
- Cylindrical or composit shanks for improved concentricity.

Code Description of the Complete Brazed Heads

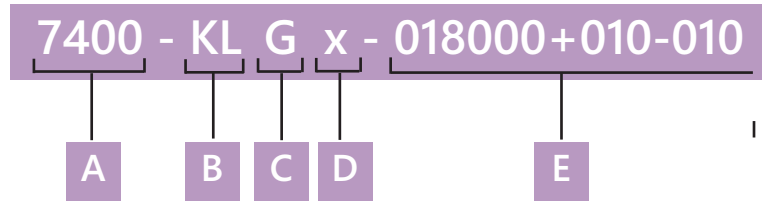

- A** A= Series
- 7400 Fixed head straight flutes
 - 7405 Expanding heads straight flutes
 - 7600 Fixed heads right hand helical flutes
 - 7605 Expanding heads right hand helical flutes
 - 7700 Fixed heads left hand helical flutes
 - 7705 Expanding heads left hand helical flutes

- B** B= Cutting material and coating

Code	Description
KL	Hard Metal cutting edges
KN	Hard Metal cutting edges N coated
KC	Hard Metal cutting edges C coated
KA	Hard Metal cutting edges A coated
KK	Hard Metal cutting edges K coated
KH	Hard Metal cutting edges H coated
SV	Cermet cutting edges
SN	Cermet cutting edges N coated
SC	Cermet cutting edges C coated
SA	Cermet cutting edges A coated
SK	Cermet cutting edges K coated
SH	Cermet cutting edges H coated

- C** C= Lead in

- D** D= Optional request:
- R = chip-breaker
 - Z = oversized tapering
 - H = half circular face

- E** E= Diameter and tolerance

SUMMARY								Short series	Central through tool coolant	Radial through tool coolant	Central & Radial through tool coolant
	Series	Page	DIAMETERS mm					Long series	Central through tool coolant	Radial through tool coolant	Central & Radial through tool coolant
			11,80	60,60	80,60						
FIXED & EXPANDING HEADS	7000MC	48+50									
	7000ML	51÷53									
	7000MM	54÷56									
	7001MC	48÷49									
	7001ML	51÷52									
	7001MM	54÷55									

Straight Flutes

Fixed Head Series 7400
&
Expanding Head Series 7405

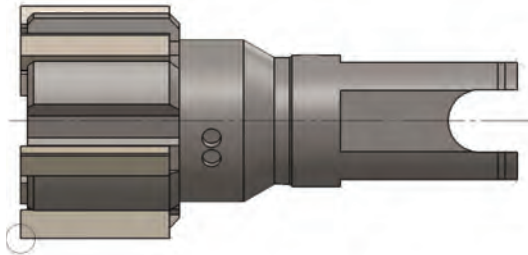

Left Hand Helical Flutes

Fixed Head Series 7700
&
Expanding Head Series 7705

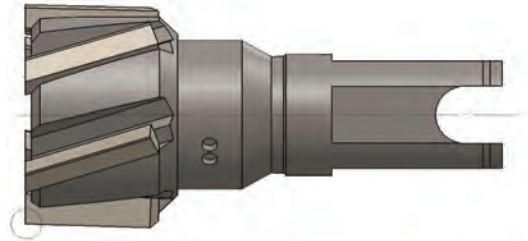

Right Hand Helical Flutes

Fixed Head Series 7600
&
Expanding Head Series 7605

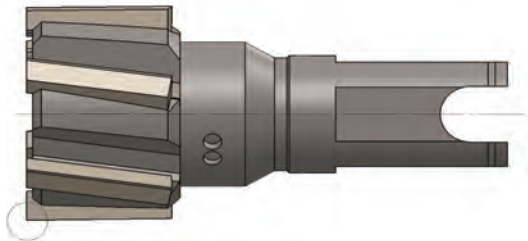

HEADS

Coated Hard metal & Cermet brazed carbide

Heads are available coated N, C, A, K, H, D.				H.M.	H.M. coated	CERMET	Straight Flutes	Helical Flutes
MATERIAL TO WORK	N / mm ²	Head Ø mm	STOCK ALLOWANCE Ø mm	SURFACE SPEED m/min	SURFACE SPEED m/min	SURFACE SPEED m/min	FEED mm/rev	FEED mm/rev
Mild Steel Unalloyed Low alloyed	Up to 600	11,80-21,60 21,61-39,60 39,61-45,59 45,60-80,60	0,15 - 0,25 0,20 - 0,40 0,30 - 0,40	10 - 20	60 - 80	90 - 300 H coated	0,25 - 0,60 0,30 - 0,80 0,60 - 1,00	0,50 - 1,00 0,60 - 1,20 0,70 - 1,50
Structural steel Fused Metal	Greater than 600	11,80-21,60 21,61-39,60 39,61-45,59 45,60-80,60	0,15 - 0,25 0,20 - 0,40 0,30 - 0,40	7 - 15	40 - 70	80 - 200 H coated	0,30 - 0,60 0,40 - 0,80 0,50 - 0,90	0,40 - 0,80 0,50 - 1,00 0,60 - 1,20
Alloy steel Stainless steel	400 - 1000	11,80-21,60 21,61-39,60 39,61-45,59 45,60-80,60	0,15 - 0,25 0,20 - 0,40 0,30 - 0,40	6 - 10	30 - 40	50 - 60	0,30 - 0,60 0,40 - 0,80 0,50 - 0,90	0,40 - 0,80 0,50 - 1,00 0,60 - 1,20
Strongly alloy steel Steel with manganese	800 - 1500	11,80-21,60 21,61-39,60 39,61-45,59 45,60-80,60	0,15 - 0,25 0,20 - 0,40 0,30 - 0,40	4 - 8	20 - 40		0,25 - 0,50 0,30 - 0,60 0,40 - 0,70	0,30 - 0,60 0,40 - 0,80 0,50 - 1,00
Grey cast iron Spheroidal cast iron (pearlitic) Malleable cast iron	Up to 200HB Greater than 200HB	11,80-21,60 21,61-39,60 39,61-45,59 45,60-80,60	0,15 - 0,25 0,20 - 0,40 0,30 - 0,40	≤ 200 HB 20 - 40 ≥ 200 HB 15 - 30	120 - 200		0,20 - 0,60 0,30 - 0,70 0,40 - 0,80	0,50 - 1,00 0,60 - 1,20 0,80 - 1,60
Spheroidal cast iron (ferritic)	300 - 700	11,80-21,60 21,61-39,60 39,61-45,59 45,60-80,60	0,15 - 0,25 0,20 - 0,40 0,30 - 0,40	10 - 15		90 - 140 K coated	0,20 - 0,60 0,30 - 0,70 0,40 - 0,80	0,50 - 1,00 0,60 - 1,20 0,80 - 1,60
Copper and alloys Brass	Up to 500	11,80-21,60 21,61-39,60 39,61-45,59 45,60-80,60	0,15 - 0,25 0,20 - 0,40 0,30 - 0,40	60 - 200	100 - 200		0,20 - 0,40 0,30 - 0,60 0,40 - 0,80	
Bronze Bronze phosphorous	Up to 600	11,80-21,60 21,61-39,60 39,61-45,59 45,60-80,60	0,15 - 0,25 0,20 - 0,40 0,30 - 0,40	20 - 40	80 - 160	100 - 300	0,30 - 0,60	0,40 - 1,00 0,50 - 1,20 0,60 - 1,50
Alluminium and light alloys	Up to 500	11,80-21,60 21,61-39,60 39,61-45,59 45,60-80,60	0,15 - 0,25 0,20 - 0,40 0,30 - 0,40	20 - 100	on request		0,30 - 0,60 0,40 - 1,00 0,40 - 1,00	
Titanium and alloys		11,80-21,60 21,61-39,60 39,61-45,59 45,60-80,60	0,15 - 0,25 0,20 - 0,40 0,30 - 0,40	6 - 10	15 - 30		0,20 - 0,40 0,30 - 0,50 0,40 - 0,60	

APPROACH ANGLES

MATERIAL TO WORK	TENSILE STRENGTH	APPROACH ANGLE*
Iron and mild steel (C < 0,2%)	50 Kg/mm ²	G - A - E
Mild steel (C 0,2 < 0,3%)	60 Kg/mm ²	N - A - E
Mild steel (C 0,3 < 0,4%)	70 Kg/mm ²	N - A - E
Mild steel (C 0,4 < 0,5%)	80 Kg/mm ²	N - A - E
Alloy steel	≤ 80 Kg/mm ²	G - N - A - E
Alloy steel	90 Kg/mm ²	G - N - E
Alloy steel	100 Kg/mm ²	G - N - M
Alloy steel	> 100 Kg/mm ²	G - N - M
Stainless and refractory steel	from 50 Kg/mm ² to 90 kg/ mm ²	G - N - M
Grey, spheroidal and malleable cast iron	from 150 HB to 320 HB	V - N - E
Titanium and titanium alloy		T - E
Pure copper		G - N - E
Electrolytic copper		G - N - E
Brass / Bronze		G - N - E
Aluminium alloy < 10% Si		V - A - E
Aluminium alloy > 11% Si		V - E
Magnesium alloy		G - A - E
Thermoplastic material		V - E
Thermosetting resins		V - E
Stiffened synthetic material		V - E

*Do not use negative lead-in on blind holes

Negative lead-in "N" can be used on large range of materials: please apply to our technical department.

SHORT SERIES 7000-MC CYLINDRICAL SHANK WITH RADIAL & CENTRAL COOLANT

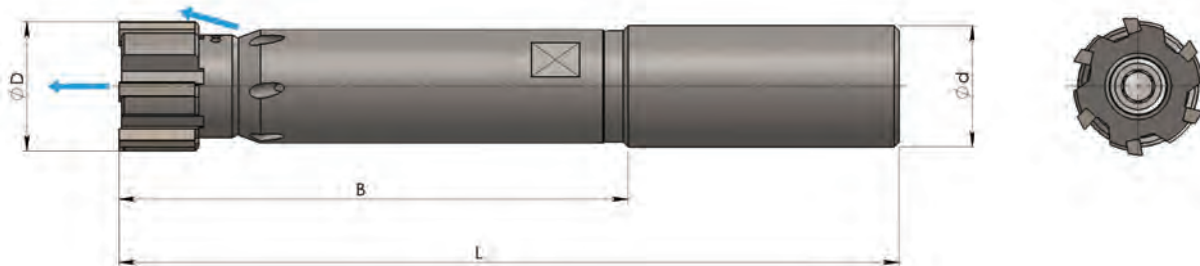

SHORT SERIES 7001-MC CYLINDRICAL SHANK WITH CENTRAL COOLANT



MANDREL CODE WITHOUT HEAD & SCREW	Ø D mm	B mm	L mm	Ø d ^{h6} mm	LOCKING SCREW FIXED HEADS		WRENCH FIXED HEADS	LOCKING SCREW EXPANDING HEADS		WRENCH EXPANDING HEADS	NUMBER OF TEETH
					THROUGH HOLES	BLIND HOLES		THROUGH HOLES	BLIND HOLES		
7000-MC-001 7001-MC-001	11,80-12,60 12,61-13,60 13,61-14,60	50	95	12	7000-VI-001	7001-VI-001	hex 2,5	7000-VI-012 7000-VI-013 7000-VI-014	7001-VI-012 7001-VI-013 7001-VI-014	hex 3,5	6 6 6
7000-MC-002 7001-MC-002	14,61-15,60 15,61-16,60 16,61-17,60	65	113	16	7000-VI-002	7001-VI-002	hex 3	7000-VI-015 7000-VI-016 7000-VI-017	7001-VI-015 7001-VI-016 7001-VI-017	hex 4	6 6 6
7000-MC-003 7001-MC-003	17,61-18,60 18,61-19,60 19,61-20,60 20,61-21,60	75	125	20	7000-VI-003	7001-VI-003	hex 4	7000-VI-018 7000-VI-019 7000-VI-020 7000-VI-021	7001-VI-018 7001-VI-019 7001-VI-020 7001-VI-021	hex 5	6 6 6 6
7000-MC-004 7001-MC-004	21,61-22,60 22,61-23,60 23,61-24,60 24,61-25,60 25,61-26,60	85	135	20	7000-VI-004	7001-VI-004	hex 5	7000-VI-022 7000-VI-023 7000-VI-024 7000-VI-025 7000-VI-026	7001-VI-022 7001-VI-023 7001-VI-024 7001-VI-025 7001-VI-026	hex 6	6 6 6 6 6

1st note mandrel 7001 fits only the locking screw for blind holes

SHORT SERIES 7000-MC
CYLINDRICAL SHANK WITH
RADIAL & CENTRAL COOLANT

SHORT SERIES 7001-MC
CYLINDRICAL SHANK
WITH CENTRAL COOLANT

MANDREL CODE WITHOUT HEAD & SCREW	Ø D mm	B mm	L mm	Ø d ^{h6} mm	LOCKING SCREW FIXED HEADS		WRENCH FIXED HEADS	LOCKING SCREW EXPANDING HEADS		WRENCH EXPANDING HEADS	NUMBER OF TEETH								
					THROUGH HOLES	BLIND HOLES		THROUGH HOLES	BLIND HOLES										
7000-MC-005 7001-MC-005	26,61-27,60	105	161	25	7000-VI-005	7001-VI-005	hex 6	7000-VI-027	7001-VI-027	hex 8	6								
	27,61-28,60							7000-VI-028	7001-VI-028		6								
	28,61-29,60							7000-VI-029	7001-VI-029		6								
	29,61-30,60							7000-VI-030	7001-VI-030		6								
	30,61-31,60							7000-VI-031	7001-VI-031		6								
	31,61-32,60							7000-VI-032	7001-VI-032		6								
7000-MC-006 7001-MC-006	32,61-33,60	120	180	32	7000-VI-006	7001-VI-006	hex 6	7000-VI-033	7001-VI-033	hex 10	6								
	33,61-34,60							7000-VI-034	7001-VI-034		6								
	34,61-35,60							7000-VI-035	7001-VI-035		6								
	35,61-36,60							7000-VI-036	7001-VI-036		6								
	36,61-37,60							7000-VI-037	7001-VI-037		6								
	37,61-38,60							7000-VI-038	7001-VI-038		6								
	38,61-39,60							7000-VI-039	7001-VI-039		6								
	39,61-40,60							7000-VI-040	7001-VI-040		6								
	7000-MC-007 7001-MC-007							40,61-41,60	120		180	32	7000-VI-007	7001-VI-007	hex 8	7000-VI-041	7001-VI-041	hex 12	6
								41,61-42,60								7000-VI-042	7001-VI-042		6
42,61-43,60		7000-VI-043	7001-VI-043	6															
43,61-44,60		7000-VI-044	7001-VI-044	6															
44,61-45,60		7000-VI-045	7001-VI-045	6															
7000-MC-075 7001-MC-075	45,61-46,60	120	180	32	7000-VI-007	7001-VI-007	hex 8	7000-VI-046	7001-VI-046	hex 12	8								
	46,61-47,60							7000-VI-047	7001-VI-047		8								
	47,61-48,60							7000-VI-048	7001-VI-048		8								
	48,61-49,60							7000-VI-049	7001-VI-049		8								
	49,61-50,60							7000-VI-050	7001-VI-050		8								
7000-MC-008 7001-MC-008	50,61-51,60	120	190	40	7000-VI-008	7001-VI-008	hex 10	7000-VI-051	7001-VI-051	hex 12	8								
	51,61-52,60							7000-VI-052	7001-VI-052		8								
	52,61-53,60							7000-VI-053	7001-VI-053		8								
	53,61-54,60							7000-VI-054	7001-VI-054		8								
	54,61-55,60							7000-VI-055	7001-VI-055		8								
	55,61-56,60							7000-VI-056	7001-VI-056		8								
	56,61-57,60							7000-VI-057	7001-VI-057		8								
	57,61-58,60							7000-VI-058	7001-VI-058		8								
	58,61-59,60							7000-VI-059	7001-VI-059		8								
	59,61-60,60							7000-VI-060	7001-VI-060		8								

All mandrels are provided with radial through tool coolant.

1st note through hole reaming - order adjustment screw to suit through holes

2nd note blind hole reaming - order adjustment screw to suit blind holes. The drilled screw allows central through tool coolant.

3rd note mandrel 7001 fits only the locking screw for blind holes

**SHORT SERIES 7000-MC
CYLINDRICAL SHANK
WITH RADIAL OR CENTRAL COOLANT**

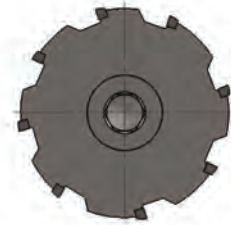
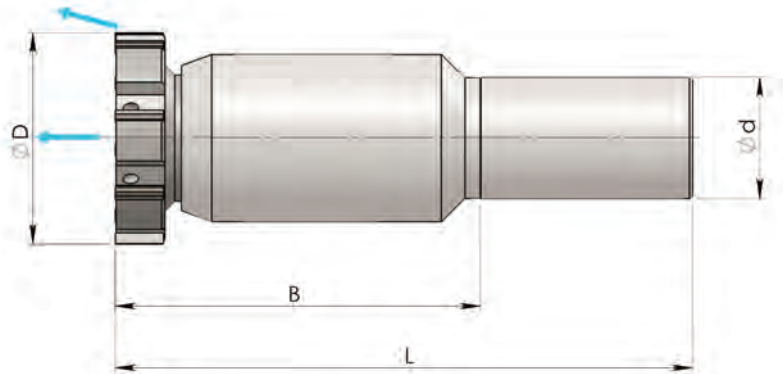

MANDREL CODE WITHOUT HEAD & SCREW	Ø D mm	B mm	L mm	Ø d ^{h6} mm	LOCKING SCREW FIXED HEADS		WRENCH FIXED HEADS	NUMBER OF TEETH
					THROUGH HOLES	BLIND HOLES		
7000-MC-009	60,61-61,60	120	190	40	7000-VI-009	7001-VI-009	hex 12	8-10-12
	61,61-62,60							8-10-12
	62,61-63,60							8-10-12
	63,61-64,60							8-10-12
	64,61-65,60							8-10-12
	65,61-66,60							8-10-12
	66,61-67,60							8-10-12
	67,61-68,60							8-10-12
	68,61-69,60							8-10-12
	69,61-70,60							8-10-12
	71,61-72,60							8-10-12
	72,61-73,60							8-10-12
	73,61-74,60							8-10-12
	74,61-75,60							8-10-12
	75,61-76,60							8-10-12
	76,61-77,60							8-10-12
	77,61-78,60							8-10-12
78,61-80,60	8-10-12							

All heads are provided with radial through tool coolant

LONG SERIES 7000-ML CYLINDRICAL SHANK WITH RADIAL & CENTRAL COOLANT

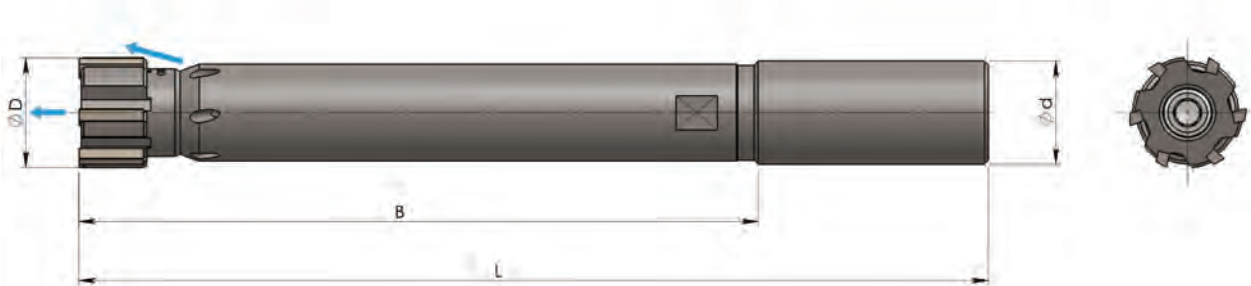

LONG SERIES 7001-ML CYLINDRICAL SHANK WITH CENTRAL COOLANT

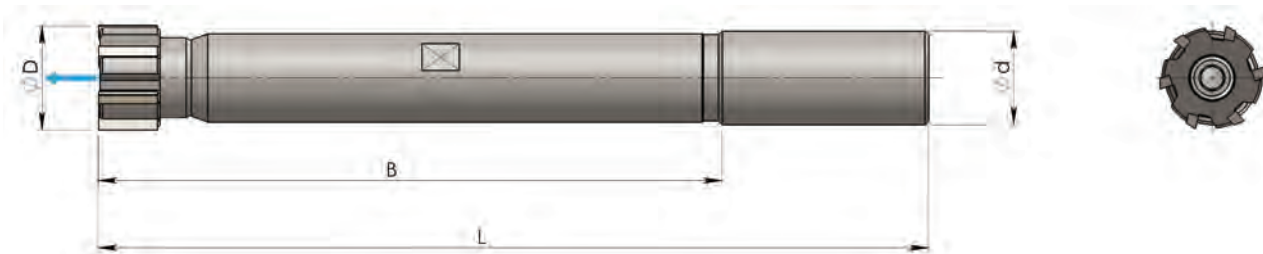

MANDREL CODE WITHOUT HEAD & SCREW	Ø D mm	B mm	L mm	Ø d ^{h6} mm	LOCKING SCREW FIXED HEADS		WRENCH FIXED HEADS	LOCKING SCREW EXPANDING HEADS		WRENCH EXPANDING HEADS	NUMBER OF TEETH
					THROUGH HOLES	BLIND HOLES		THROUGH HOLES	BLIND HOLES		
7000-ML-001 7001-ML-001	11,80-12,60 12,61-13,60 13,61-14,60	95	140	12	7000-VI-001	7001-VI-001	hex 2,5	7000-VI-012 7000-VI-013 7000-VI-014	7001-VI-012 7001-VI-013 7001-VI-014	hex 3,5	6 6 6
7000-ML-002 7001-ML-002	14,61-15,60 15,61-16,60 16,61-17,60	105	153	16	7000-VI-002	7001-VI-002	hex 3	7000-VI-015 7000-VI-016 7000-VI-017	7001-VI-015 7001-VI-016 7001-VI-017	hex 4	6 6 6
7000-ML-003 7001-ML-003	17,61-18,60 18,61-19,60 19,61-20,60 20,61-21,60	125	175	20	7000-VI-003	7001-VI-003	hex 4	7000-VI-018 7000-VI-019 7000-VI-020 7000-VI-021	7001-VI-018 7001-VI-019 7001-VI-020 7001-VI-021	hex 5	6 6 6 6
7000-ML-004 7001-ML-004	21,61-22,60 22,61-23,60 23,61-24,60 24,61-25,60 25,61-26,60	145	195	20	7000-VI-004	7001-VI-004	hex 5	7000-VI-022 7000-VI-023 7000-VI-024 7000-VI-025 7000-VI-026	7001-VI-022 7001-VI-023 7001-VI-024 7001-VI-025 7001-VI-026	hex 6	6 6 6 6 6

1st note mandrel 7001 fits only the locking screw for blind holes

LONG SERIES 7000-ML CYLINDRICAL SHANK WITH RADIAL & CENTRAL COOLANT

LONG SERIES 7001-ML CYLINDRICAL SHANK WITH CENTRAL COOLANT

MANDREL CODE WITHOUT HEAD & SCREW	Ø D mm	B mm	L mm	Ø d ^{h6} mm	LOCKING SCREW FIXED HEADS		WRENCH FIXED HEADS	LOCKING SCREW EXPANDING HEADS		WRENCH EXPANDING HEADS	NUMBER OF TEETH									
					THROUGH HOLES	BLIND HOLES		THROUGH HOLES	BLIND HOLES											
7000-ML-005 7001-ML-005	26,61-27,60	165	221	25	7000-VI-005	7001-VI-005	hex 6	7000-VI-027	7001-VI-027	hex 8	6									
	27,61-28,60							7000-VI-028	7001-VI-028											
	28,61-29,60							7000-VI-029	7001-VI-029											
	29,61-30,60							7000-VI-030	7001-VI-030											
	30,61-31,60							7000-VI-031	7001-VI-031											
	31,61-32,60							7000-VI-032	7001-VI-032											
7000-ML-006 7001-ML-006	32,61-33,60	185	245	32	7000-VI-006	7001-VI-006	hex 6	7000-VI-033	7001-VI-033	hex 10	6									
	33,61-34,60							7000-VI-034	7001-VI-034											
	34,61-35,60							7000-VI-035	7001-VI-035											
	35,61-36,60							7000-VI-036	7001-VI-036											
	36,61-37,60							7000-VI-037	7001-VI-037											
	37,61-38,60							7000-VI-038	7001-VI-038											
	38,61-39,60							7000-VI-039	7001-VI-039											
	39,61-40,60							7000-VI-040	7001-VI-040											
	7000-ML-007 7001-ML-007							40,61-41,60	185			245	32	7000-VI-007	7001-VI-007	hex 8	7000-VI-041	7001-VI-041	hex 12	6
								41,61-42,60									7000-VI-042	7001-VI-042		
42,61-43,60		7000-VI-043	7001-VI-043																	
43,61-44,60		7000-VI-044	7001-VI-044																	
44,61-45,60		7000-VI-045	7000-VI-045																	
7000-ML-075 7001-ML-075	45,61-46,60	185	245	32	7000-VI-007	7001-VI-007	hex 8	7000-VI-046	7001-VI-046	hex 12	8									
	46,61-47,60							7000-VI-047	7001-VI-047											
	47,61-48,60							7000-VI-048	7001-VI-048											
	48,61-49,60							7000-VI-049	7001-VI-049											
	49,61-50,60							7000-VI-050	7001-VI-050											
7000-ML-008 7001-ML-008	50,61-51,60	185	255	40	7000-VI-008	7001-VI-008	hex 10	7000-VI-051	7001-VI-051	hex 12	8									
	51,61-52,60							7000-VI-052	7001-VI-052											
	52,61-53,60							7000-VI-053	7001-VI-053											
	53,61-54,60							7000-VI-054	7001-VI-054											
	54,61-55,60							7000-VI-055	7001-VI-055											
	55,61-56,60							7000-VI-056	7001-VI-056											
	56,61-57,60							7000-VI-057	7001-VI-057											
	57,61-58,60							7000-VI-058	7001-VI-058											
	58,61-59,60							7000-VI-059	7001-VI-059											
	59,61-60,60							7000-VI-060	7001-VI-060											

All mandrels are provided with radial through tool coolant.

1st note through hole reaming - order adjustment screw to suit through holes

2nd note blind hole reaming - order adjustment screw to suit blind holes. The drilled screw allows central through tool coolant

3rd note mandrel 7001 fits only the locking screw for blind holes

LONG SERIES 7000-ML CYLINDRICAL SHANK WITH RADIAL OR CENTRAL COOLANT

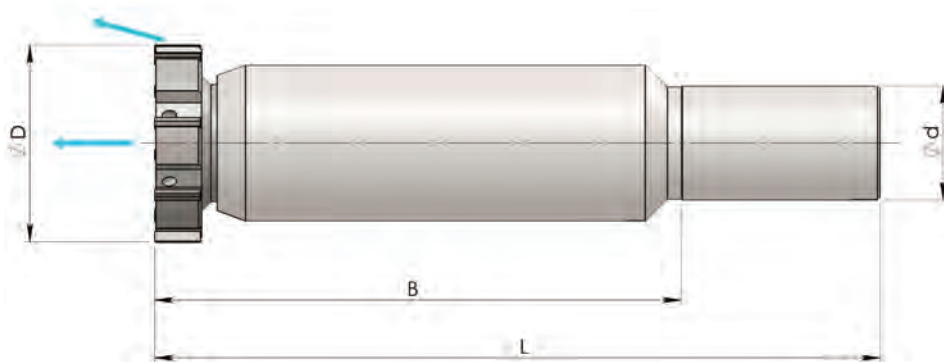

MANDREL CODE WITHOUT HEAD & SCREW	Ø D mm	B mm	L mm	Ø d ^{h6} mm	LOCKING SCREW FIXED HEADS		WRENCH FIXED HEADS	NUMBER OF TEETH
					THROUGH HOLES	BLIND HOLES		
7000-ML-009	60,61-61,60	185	255	40	7000-VI-009	7001-VI-009	hex 12	8-10-12
	61,61-62,60							8-10-12
	62,61-63,60							8-10-12
	63,61-64,60							8-10-12
	64,61-65,60							8-10-12
	65,61-66,60							8-10-12
	66,61-67,60							8-10-12
	67,61-68,60							8-10-12
	68,61-69,60							8-10-12
	69,61-70,60							8-10-12
	71,61-72,60							8-10-12
	72,61-73,60							8-10-12
	73,61-74,60							8-10-12
	74,61-75,60							8-10-12
	75,61-76,60							8-10-12
	76,61-77,60							8-10-12
	77,61-78,60							8-10-12
78,61-80,60	8-10-12							

All heads are provided with radial through tool coolant

SERIES 7000-MM MODULAR SHANK WITH RADIAL & CENTRAL COOLANT

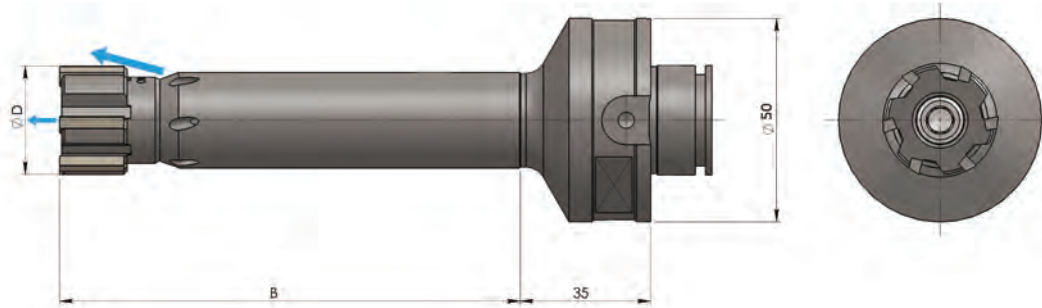

SERIES 7001-MM MODULAR SHANK WITH CENTRAL COOLANT

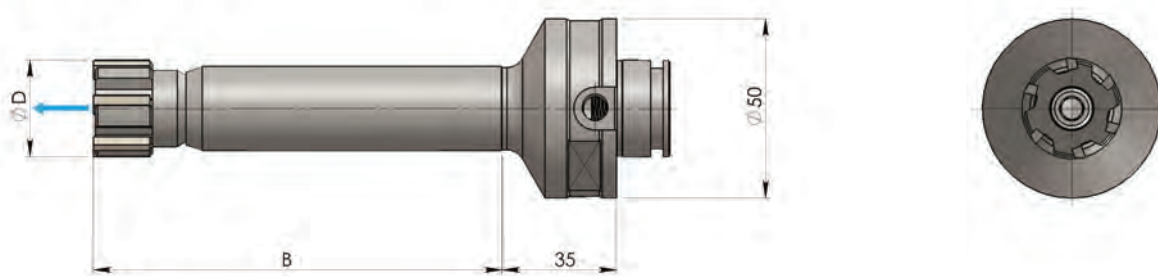

MANDREL CODE WITHOUT HEAD & SCREW	Ø D mm	B mm	LOCKING SCREW FIXED HEADS		WRENCH FIXED HEADS	LOCKING SCREW EXPANDING HEADS		WRENCH EXPANDING HEADS	NUMBER OF TEETH
			THROUGH HOLES	BLIND HOLES		THROUGH HOLES	BLIND HOLES		
7000-MM-001	11,80-12,60	65	7000-VI-001	7001-VI-001	hex 2,5	7000-VI-012	7001-VI-012	hex 3,5	6
7001-MM-001	12,61-13,60					7000-VI-013	7001-VI-013		6
	13,61-14,60					7000-VI-014	7001-VI-014		6
7000-MM-002	14,61-15,60	80	7000-VI-002	7001-VI-002	hex 3	7000-VI-015	7001-VI-015	hex 4	6
7001-MM-002	15,61-16,60					7000-VI-016	7001-VI-016		6
	16,61-17,60					7000-VI-017	7001-VI-017		6
7000-MM-003	17,61-18,60	90	7000-VI-003	7001-VI-003	hex 4	7000-VI-018	7001-VI-018	hex 5	6
7001-MM-003	18,61-19,60					7000-VI-019	7001-VI-019		6
	19,61-20,60					7000-VI-020	7001-VI-020		6
	20,61-21,60					7000-VI-021	7001-VI-021		6

1st note mandrel 7001 fits only the locking screw for blind holes

**SERIES 7000-MM
MODULAR SHANK WITH
RADIAL & CENTRAL COOLANT**

**SERIES 7001-MM
MODULAR SHANK
WITH CENTRAL COOLANT**

MANDREL CODE WITHOUT HEAD & SCREW	Ø D mm	B mm	LOCKING SCREW FIXED HEADS		WRENCH FIXED HEADS	LOCKING SCREW EXPANDING HEADS		WRENCH EXPANDING HEADS	NUMBER OF TEETH
			THROUGH HOLES	BLIND HOLES		THROUGH HOLES	BLIND HOLES		
7000-MM-004 7001-MM-004	21,61-22,60	100	7000-VI-004	7001-VI-004	hex 5	7000-VI-022	7001-VI-022	hex 6	6
	22,61-23,60					7000-VI-023	7001-VI-023		6
	23,61-24,60					7000-VI-024	7001-VI-024		6
	24,61-25,60					7000-VI-025	7001-VI-025		6
	25,61-26,60					7000-VI-026	7001-VI-026		6
7000-MM-005 7001-MM-005	26,61-27,60	110	7000-VI-005	7001-VI-005	hex 6	7000-VI-027	7001-VI-027	hex 8	6
	27,61-28,60					7000-VI-028	7001-VI-028		6
	28,61-29,60					7000-VI-029	7001-VI-029		6
	29,61-30,60					7000-VI-030	7001-VI-030		6
	30,61-31,60					7000-VI-031	7001-VI-031		6
	31,61-32,60					7000-VI-032	7001-VI-032		6
7000-MM-006 7001-MM-006	32,61-33,60	120	7000-VI-006	7001-VI-006	hex 6	7000-VI-033	7001-VI-033	hex 10	6
	33,61-34,60					7000-VI-034	7001-VI-034		6
	34,61-35,60					7000-VI-035	7001-VI-035		6
	35,61-36,60					7000-VI-036	7001-VI-036		6
	36,61-37,60					7000-VI-037	7001-VI-037		6
	37,61-38,60					7000-VI-038	7001-VI-038		6
	38,61-39,60					7000-VI-039	7001-VI-039		6
	39,61-40,60					7000-VI-040	7001-VI-040		6
	7000-MM-007 7001-MM-007					40,61-41,60	120		7000-VI-007
41,61-42,60		7000-VI-042	7001-VI-042	6					
42,61-43,60		7000-VI-043	7001-VI-043	6					
43,61-44,60		7000-VI-044	7001-VI-044	6					
44,61-45,60		7000-VI-045	7001-VI-045	6					
7000-MM-075 7001-MM-075	45,61-46,60	120	7000-VI-007	7001-VI-007	hex 8	7000-VI-046	7001-VI-046	hex 12	8
	46,61-47,60					7000-VI-047	7001-VI-047		8
	47,61-48,60					7000-VI-048	7001-VI-048		8
	48,61-49,60					7000-VI-049	7001-VI-049		8
	49,61-50,60					7000-VI-050	7001-VI-050		8
7000-MM-008 7001-MM-008	50,61-51,60	120	7000-VI-008	7001-VI-008	hex 10	7000-VI-051	7001-VI-051	hex 12	8
	51,61-52,60					7000-VI-052	7001-VI-052		8
	52,61-53,60					7000-VI-053	7001-VI-053		8
	53,61-54,60					7000-VI-054	7001-VI-054		8
	54,61-55,60					7000-VI-055	7001-VI-055		8
	55,61-56,60					7000-VI-056	7001-VI-056		8
	56,61-57,60					7000-VI-057	7001-VI-057		8
	57,61-58,60					7000-VI-058	7001-VI-058		8
	58,61-59,60					7000-VI-059	7001-VI-059		8
	59,61-60,60					7000-VI-060	7001-VI-060		8

All mandrels are provided with radial through tool coolant.

1st note through hole reaming - order adjustment screw to suit through holes

2nd note blind hole reaming - order adjustment screw to suit blind holes. The drilled screw allows central through tool coolant.

3rd note mandrel 7001 fits only the locking screw for blind holes

**SERIES 7000-MM
MODULAR "COMPOSIT" SHANK
WITH RADIAL OR CENTRAL COOLANT**

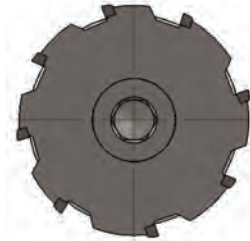
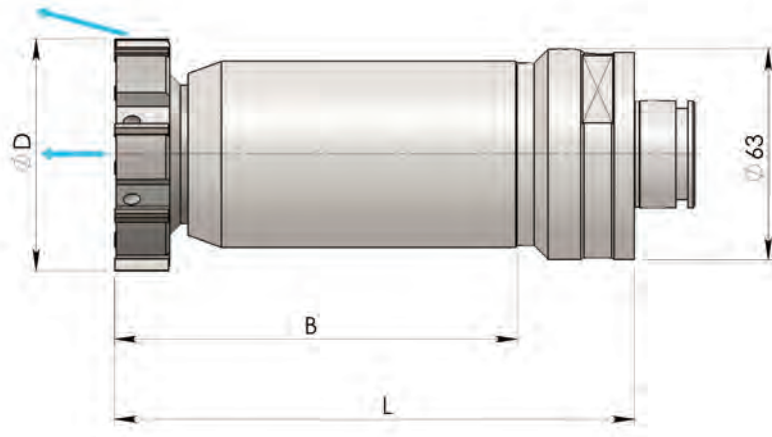

MANDREL CODE WITHOUT HEAD & SCREW	Ø D mm	B mm	L mm	LOCKING SCREW FIXED HEADS		WRENCH FIXED HEADS	NUMBER OF TEETH
				THROUGH HOLES	BLIND HOLES		
7000-MM-009	60,61-61,60	120	155	7000-VI-009	7001-VI-009	hex 12	8-10-12
	61,61-62,60						8-10-12
	62,61-63,60						8-10-12
	63,61-64,60						8-10-12
	64,61-65,60						8-10-12
	65,61-66,60						8-10-12
	66,61-67,60						8-10-12
	67,61-68,60						8-10-12
	68,61-69,60						8-10-12
	69,61-70,60						8-10-12
	71,61-72,60						8-10-12
	72,61-73,60						8-10-12
	73,61-74,60						8-10-12
	74,61-75,60						8-10-12
	75,61-76,60						8-10-12
	76,61-77,60						8-10-12
	77,61-78,60						8-10-12
78,61-80,60	8-10-12						

All heads are provided with radial through tool coolant

Series 5000 for high production



Features & Benefits

- Series: 5400-5401-5600-5700
- Diameter range from 9,61 to 32,60 mm
- Oversized diameter range from 32,61 to 40,60 mm only on request
- Available in carbide or cermet, coated or uncoated
- Easy to assembly
- Easy to use
- Expanding heads only
- Straight, left or right hand helical flutes making through or blind holes achievable
- Cylindrical or composit shanks for improved concentricity
- Throw-away heads

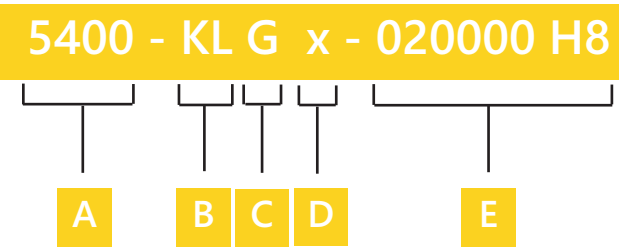

A A= Series
 5400 Straight flutes with radial coolant
 5401 Straight flutes with central coolant
 5600 Right hand helical flutes with central coolant
 5700 Left hand helical flutes with radial coolant

B B= Cutting material and coating

Code	Description
KL	Hard Metal cutting edges
KN	Hard Metal cutting edges N coated
KC	Hard Metal cutting edges C coated
KA	Hard Metal cutting edges A coated
KK	Hard Metal cutting edges K coated
KH	Hard Metal cutting edges H coated
SV	Cermet cutting edges
SN	Cermet cutting edges N coated
SC	Cermet cutting edges C coated
SA	Cermet cutting edges A coated
SK	Cermet cutting edges K coated
SH	Cermet cutting edges H coated

C C= Lead in

D D= Specific requirement:
 H= half circular face
 Z= oversized tapering

E E= Diameter and tolerance

STRAIGHT FLUTES

For reaming
through and blind holes

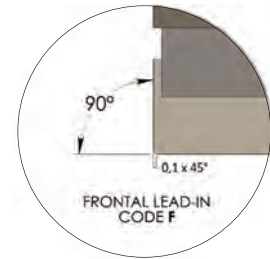
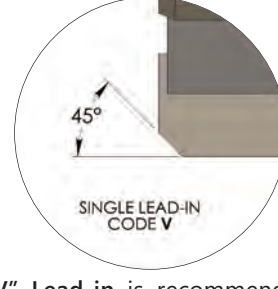
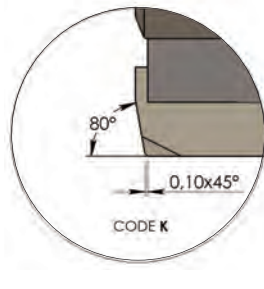
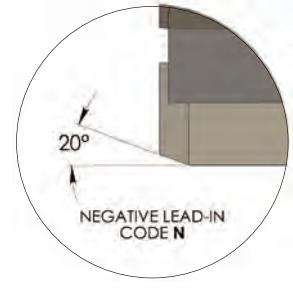
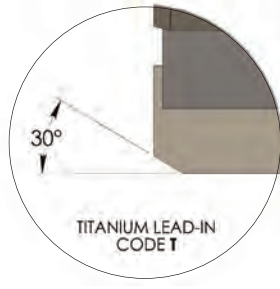
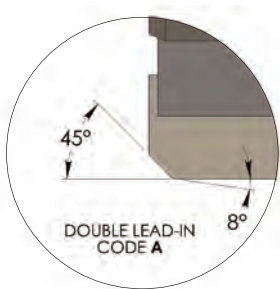

Chipbreaker

"V" Lead-in is recommended
for high cutting speed

"F" Lead-in to reduce the
feed of 40% compared with
the values on pages 8-9

HELICAL FLUTES

Helical left flutes: For reaming through holes only

Helical right flutes: For reaming blind holes only

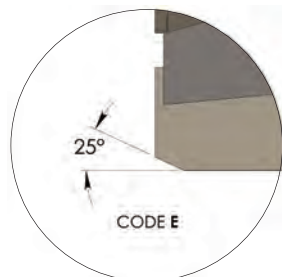

"E" Lead-in is suitable to working
most materials such as cast iron,
steel and aluminium

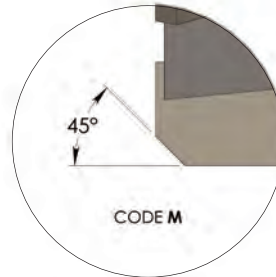

"M" Lead-in allows an easier depth
penetration in steels with a surface
hardness greater than 200 HB

			HARD METAL UNCOATED	HARD METAL COATED					CERMET UNCOATED	CERMET COATED					STRAIGHT FLUTES	HELICAL FLUTES
				N	C	A	K	H		N	C	A	K	H		
MATERIAL TO WORK	HEAD Ø mm	STOCK ALLOWANCE Ø mm	SURFACE SPEED m/min	SURFACE SPEED m/min					SURFACE SPEED m/min	SURFACE SPEED m/min					FEED mm/rev	FEED mm/rev
Non-alloy steel	9,61- 17,60 17,61- 26,60 26,61- 32,60	0,15 - 0,25 0,20 - 0,40 0,30 - 0,40	15÷20	60÷80					120÷200					120÷200	0,30 - 0,60 0,40 - 0,80 0,50 - 0,90	0,40 - 0,80 0,50 - 1,00 0,60 - 1,20
Automatic steel	9,61- 17,60 17,61- 26,60 26,61- 32,60	0,15 - 0,25 0,20 - 0,40 0,30 - 0,40	20÷40	80÷100					120÷200					120÷200	0,30 - 0,60 0,40 - 0,80 0,50 - 0,90	0,40 - 0,80 0,50 - 1,00 0,60 - 1,20
Medium-alloy steel	9,61- 17,60 17,61- 26,60 26,61- 32,60	0,15 - 0,25 0,20 - 0,40 0,30 - 0,40	10÷15	50÷80					100÷150						0,30 - 0,60 0,40 - 0,80 0,50 - 0,90	0,40 - 0,80 0,50 - 1,00 0,60 - 1,20
Strongly alloy steel	9,61- 17,60 17,61- 26,60 26,61- 32,60	0,15 - 0,25 0,20 - 0,40 0,30 - 0,40	8÷10	30÷40											0,25 - 0,50 0,30 - 0,60 0,40 - 0,70	0,30 - 0,60 0,40 - 0,80 0,50 - 1,00
Austenitic steel	9,61- 17,60 17,61- 26,60 26,61- 32,60	0,15 - 0,25 0,20 - 0,40 0,30 - 0,40	8÷10				30÷40								0,25 - 0,50 0,30 - 0,60 0,40 - 0,70	0,30 - 0,60 0,40 - 0,80 0,50 - 1,00
Martensitic stainless steel	9,61- 17,60 17,61- 26,60 26,61- 32,60	0,15 - 0,25 0,20 - 0,40 0,30 - 0,40	8÷10						50÷60						0,25 - 0,50 0,30 - 0,60 0,40 - 0,70	0,30 - 0,60 0,40 - 0,80 0,50 - 1,00
Spheroidal cast iron GS400-500	9,61- 17,60 17,61- 26,60 26,61- 32,60	0,15 - 0,25 0,20 - 0,40 0,30 - 0,40	15÷20										100÷120		0,30 - 0,60 0,30 - 0,60 0,40 - 0,80	0,50 - 1,00 0,60 - 1,20 0,60 - 1,20
Spheroidal cast iron GS600-700	9,61- 17,60 17,61- 26,60 26,61- 32,60	0,15 - 0,25 0,20 - 0,40 0,30 - 0,40	15÷20										100÷120		0,30 - 0,60 0,30 - 0,60 0,40 - 0,80	0,50 - 1,00 0,60 - 1,20 0,60 - 1,20
Grey cast iron	9,61- 17,60 17,61- 26,60 26,61- 32,60	0,15 - 0,25 0,20 - 0,40 0,30 - 0,40	20÷30			150÷200									0,30 - 0,60 0,30 - 0,60 0,40 - 0,80	0,50 - 1,00 0,60 - 1,20 0,60 - 1,20
Copper	9,61- 17,60 17,61- 26,60 26,61- 32,60	0,15 - 0,25 0,20 - 0,40 0,30 - 0,40	80÷100	100÷200											0,30 - 0,60 0,40 - 0,80 0,50 - 0,90	0,40 - 0,80 0,50 - 1,00 0,60 - 1,20
Bronze	9,61- 17,60 17,61- 26,60 26,61- 32,60	0,15 - 0,25 0,20 - 0,40 0,30 - 0,40	40÷80	80÷160					150÷200						0,30 - 0,60 0,40 - 0,80 0,50 - 0,90	0,40 - 0,80 0,50 - 1,00 0,60 - 1,20
Titanium	9,61- 17,60 17,61- 26,60 26,61- 32,60	0,15 - 0,25 0,20 - 0,40 0,30 - 0,40	10÷15												0,25 - 0,50 0,30 - 0,60 0,40 - 0,70	0,30 - 0,60 0,40 - 0,80 0,50 - 1,00
Special alloys: Inconel, etc...	9,61- 17,60 17,61- 26,60 26,61- 32,60	0,15 - 0,25 0,20 - 0,40 0,30 - 0,40	5÷7				20÷30								0,25 - 0,50 0,30 - 0,60 0,40 - 0,70	0,30 - 0,60 0,40 - 0,80 0,50 - 1,00
Aluminium <1% Si	9,61- 17,60 17,61- 26,60 26,61- 32,60	0,15 - 0,25 0,20 - 0,40 0,30 - 0,40	30÷60												0,30 - 0,60 0,30 - 0,60 0,40 - 0,80	0,50 - 1,00 0,60 - 1,20 0,60 - 1,20
Aluminium >7% Si	9,61- 17,60 17,61- 26,60 26,61- 32,60	0,15 - 0,25 0,20 - 0,40 0,30 - 0,40	PCD or DLC coated 100÷300											0,30 - 0,60 0,30 - 0,60 0,40 - 0,80	0,50 - 1,00 0,60 - 1,20 0,60 - 1,20	

Through holes
with radial
tool coolant

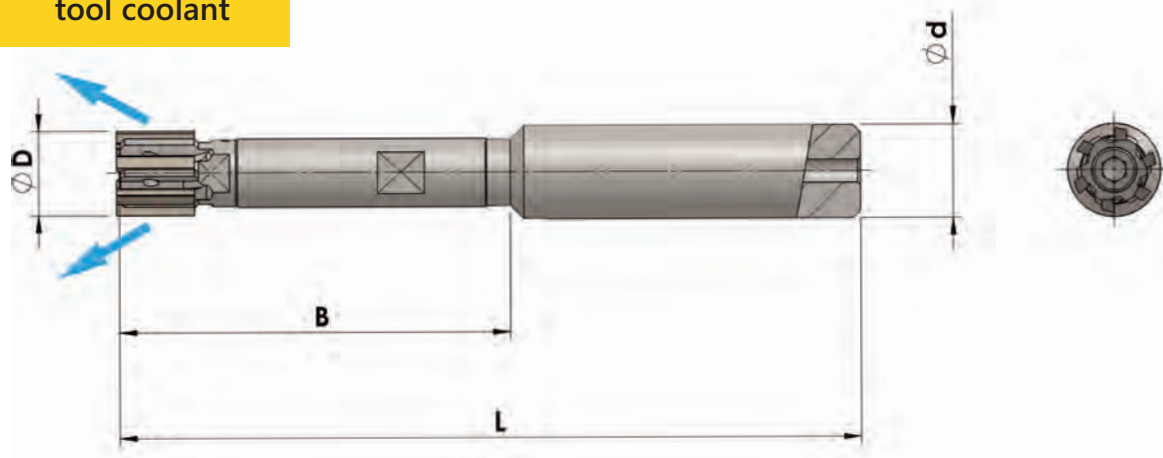

Blind holes
with central
tool coolant

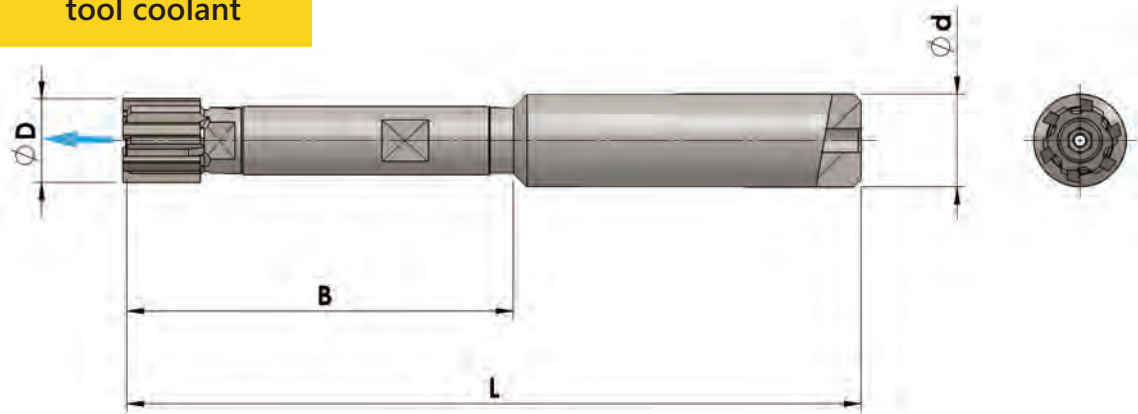

Head Mandrel - Short Series 5000-MC

Mandrel Code	Ø D (mm)	B (mm)	L (mm)	Ød h6 (mm)
5000-MC-001	9,60÷11,60	50	95	12
5000-MC-002	11,61÷14,60	50	95	12
5000-MC-003	14,61÷17,60	65	113	16
5000-MC-004	17,61÷21,60	75	125	20
5000-MC-005	21,61÷26,60	85	135	20
5000-MC-006	26,61÷32,60	105	161	25

Through holes
with radial
tool coolant

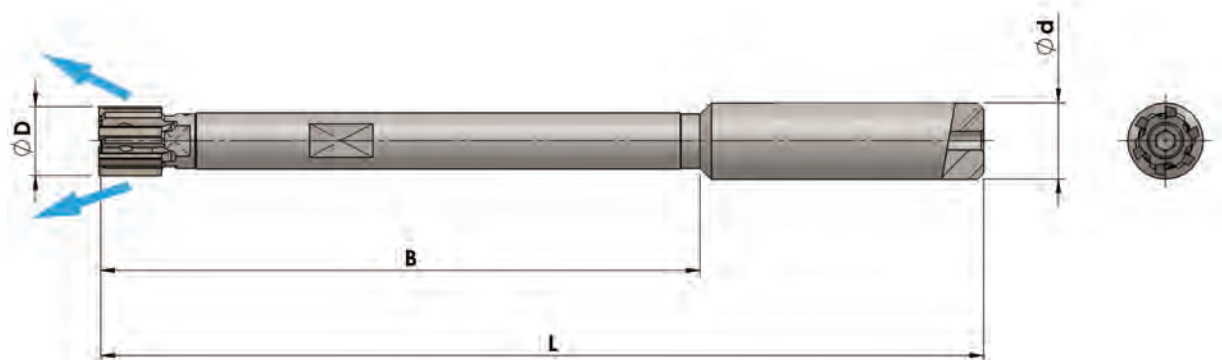

Blind holes
with central
tool coolant

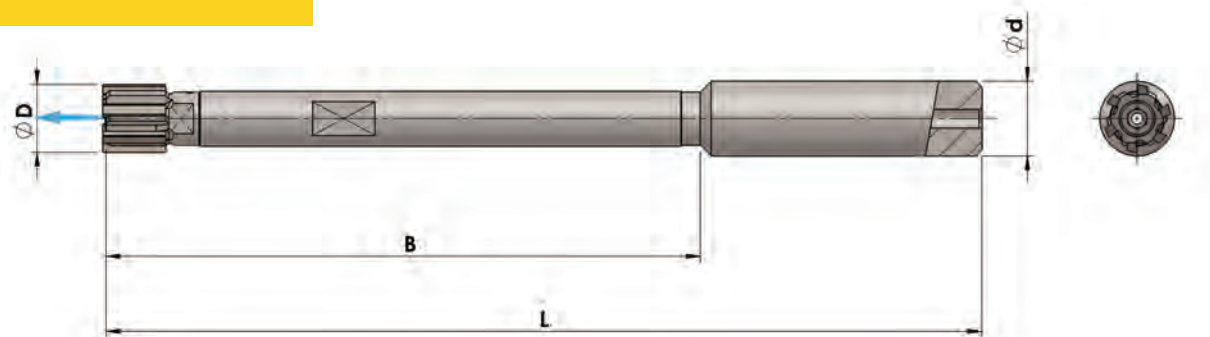

Head Mandrel - Long Series 5000-ML

Mandrel Code	Ø D (mm)	B (mm)	L (mm)	Ød h6 (mm)
5000-ML-001	9,60 ÷ 11,60	95	140	12
5000-ML-002	11,61 ÷ 14,60	95	140	12
5000-ML-003	14,61 ÷ 17,60	105	153	16
5000-ML-004	17,61 ÷ 21,60	125	175	20
5000-ML-005	21,61 ÷ 26,60	145	195	20
5000-ML-006	26,61 ÷ 32,60	165	221	25

Through holes
with radial
tool coolant

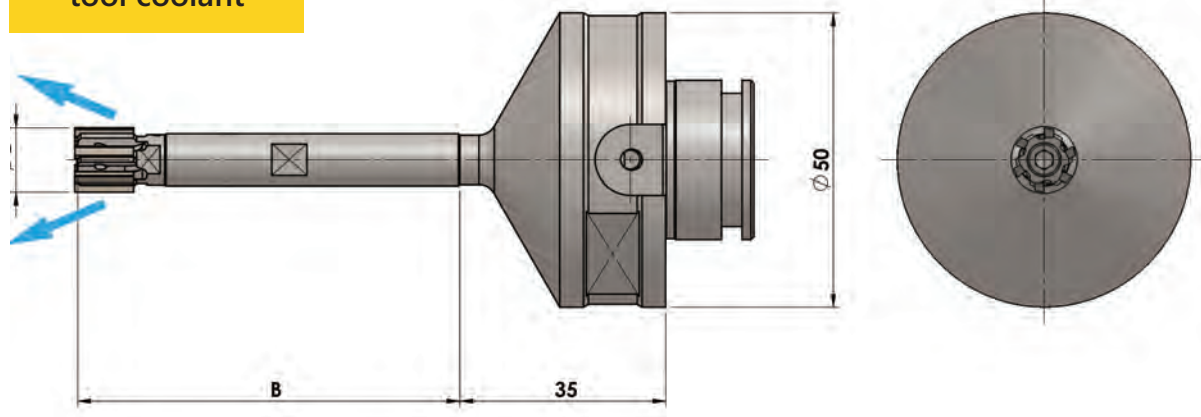

Blind holes
with central
tool coolant

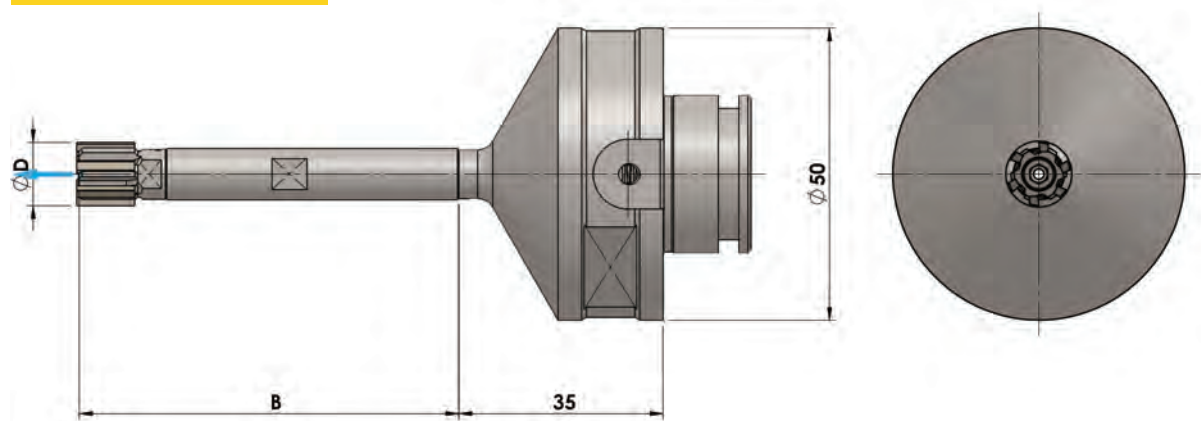

Series 5000-MM

Mandrel Code	Ø D (mm)	B (mm)	B (mm)
5000-MM-001	9,60÷11,60	65	
5000-MM-002	11,61÷14,60	65	
5000-MM-003	14,61÷17,60	80	
5000-MM-004	17,61÷21,60	100	
5000-MM-005	21,61÷26,60	110	
5000-MM-006	26,61÷32,60	120	

Modular system is courtesy of  more information are available on our reaming catalogue

TSA System

SINTERED SOLUTION
TSA
System



Features & Benefits

- Series: 9400 - 9600 - 9700
- Diameter range from 11.80 to 40.60 mm.
- Heads are fixed and you have to throw away after use..
- Straight, left, or right hand helical flutes making through or blind holes achievable.
- Cylindrical or composit shanks for improved concentricity.

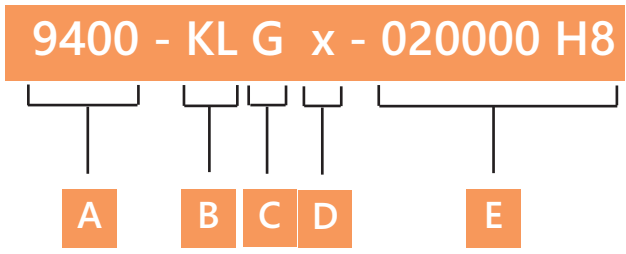

A A= Series 9400 Straight flutes
 9600 Right hand helica flutes
 9700 Left hand helical flutes

B B= Cutting material and coating

Code	Description
KL	Hard Metal cutting edges
KN	Hard Metal cutting edges N coated
KC	Hard Metal cutting edges C coated
KA	Hard Metal cutting edges A coated
KK	Hard Metal cutting edges K coated
KH	Hard Metal cutting edges H coated
AV	Cermet cutting edges
AN	Cermet cutting edges N coated
AC	Cermet cutting edges C coated
AA	Cermet cutting edges A coated
AK	Cermet cutting edges K coated
AH	Cermet cutting edges H coated

C C= Lead in

D D= Optional demand:
 R= chip-breaker
 Z= oversized tapering
 H= half circular face

E E= Diameter and tolerance

SERIES 9400

STRAIGHT FLUTES

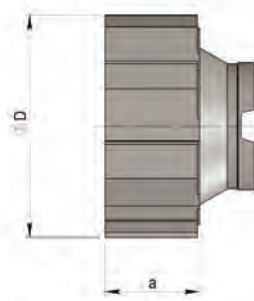

SERIES 9600

RIGHT HAND HELICAL FLUTES

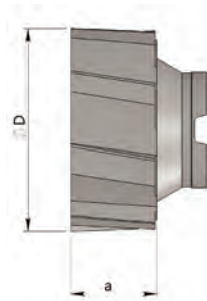

SERIES 9700

LEFT HAND HELICAL FLUTES

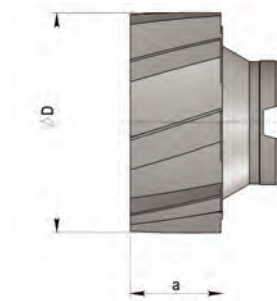

Ø D (mm)	a (mm)	number of teeth
11,80÷14,60	10	6
14,61÷17,60	10	6
17,61÷21,60	10	6
21,61÷26,60	10	8
26,60÷32,60	10	8
32,61÷40,60	10	10



ADVANTAGE OF TSA SYSTEM

The opportunity to replace the heads directly in the machine, without disassembly the mandrel from the basic shank, permits a reduction of dead times.

STRAIGHT FLUTES

Suggested to ream through and blind holes

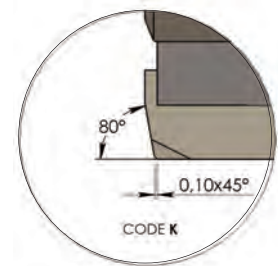
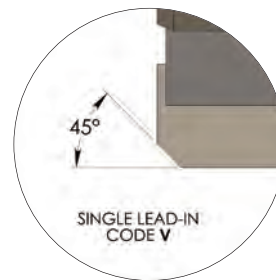
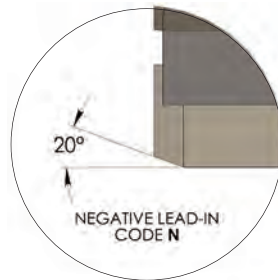
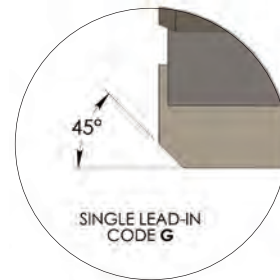
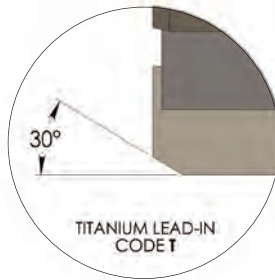
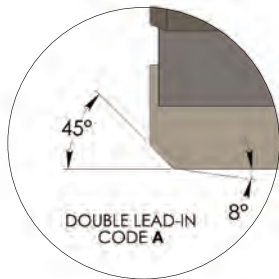

"V" Lead-in is recommended for high cutting speed

Chipbreaker

HELICAL FLUTES

Suggested only to ream through holes

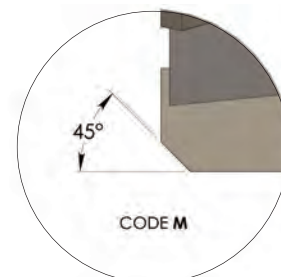
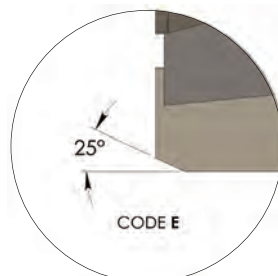
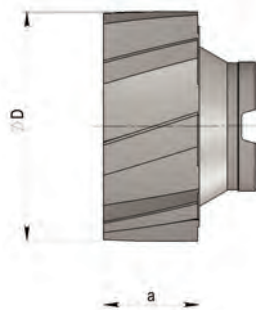

"E" Lead-in is suitable to work most of materials as cast iron, steel and aluminium

"M" Lead-in allows an easier depth penetration in steels with surface hardness greater than 200 HB

Hard metal or Cermet carbide uncoated
 Hard metal or Cermet carbide N - C - A - K - H - coated

				HARD METAL UNCOATED	HARD METAL COATED						CERMET COATED UNCOATED	STRAIGHT FLUTES	HELICAL FLUTES
					N	C	A	K	H	D			
MATERIAL TO WORK	N/mm ²	HEAD Ø mm	STOCK ALLOWANCE Ø mm	SURFACE SPEED m/min	SURFACE SPEED m/min						SURFACE SPEED m/min	FEED mm/rev	FEED mm/rev
Mild Steel Unalloyed	Up to 600	11,80 - 21,60	0,15 - 0,25	10 - 20	60 - 80						90 - 300 H coated	0,25 - 0,60	0,50 - 1,00
Low alloyed		21,61 - 39,60	0,20 - 0,40									0,30 - 0,40	0,30 - 0,80
Structural steel Fused Metal	Greater than 600	11,80 - 21,60	0,15 - 0,25	7 - 15			40 - 70				80 - 200 H coated	0,30 - 0,60	0,40 - 0,80
		21,61 - 39,60	0,20 - 0,40									0,40 - 0,80	0,50 - 1,00
		39,61 - 40,60	0,30 - 0,40									0,50 - 0,90	0,60 - 1,20
Stainless steel	400- 1000	11,80 - 21,60	0,15 - 0,25	6 - 10				30 - 40			50 - 60	0,30 - 0,60	0,40 - 0,80
		21,61 - 39,60	0,20 - 0,40									0,40 - 0,80	0,50 - 1,00
		39,61 - 40,60	0,30 - 0,40									0,50 - 0,90	0,60 - 1,20
Strongly alloy steel	800- 1500	11,80 - 21,60	0,15 - 0,25	4 - 8				20 - 40				0,25 - 0,50	0,30 - 0,60
Steel with manganese		21,61 - 39,60	0,20 - 0,40									0,30 - 0,40	0,30 - 0,60
		39,61 - 40,60	0,30 - 0,40									0,40 - 0,70	0,50 - 1,00
Grey cast iron Spheroidal cast iron (pearlitic)	Up to 200 HB	11,80 - 21,60	0,15 - 0,25	≤200 HB 20 - 40			120 - 200					0,20 - 0,60	0,50 - 1,00
		21,61 - 39,60	0,20 - 0,40									0,30 - 0,70	0,60 - 1,20
Malleable cast iron	Greater than 200 HB	39,61 - 40,60	0,30 - 0,40	≥200 HB 15 - 30								0,40 - 0,80	0,80 - 1,60
Spheroidal cast iron (ferritic)	300- 700	11,80 - 21,60	0,15 - 0,25	10 - 15							90 - 140 K coated	0,20 - 0,60	0,50 - 1,00
		21,61 - 39,60	0,20 - 0,40									0,30 - 0,70	0,60 - 1,20
		39,61 - 40,60	0,30 - 0,40									0,40 - 0,80	0,80 - 1,60
Copper and alloys Brass	Up to 500	11,80 - 21,60	0,15 - 0,25	60 - 200	100 - 200							0,20 - 0,40	
		21,61 - 39,60	0,20 - 0,40									0,30 - 0,60	
		39,61 - 40,60	0,30 - 0,40									0,40 - 0,80	
Bronze Bronze phosphorous	Up to 600	11,80 - 21,60	0,15 - 0,25	20 - 40	80 - 160						100 - 300	0,30 - 0,60	0,40 - 1,00
		21,61 - 39,60	0,20 - 0,40									0,50 - 1,20	0,50 - 1,20
		39,61 - 40,60	0,30 - 0,40									0,60 - 1,50	0,60 - 1,50
Alluminium and light alloys	Up to 500	11,80 - 21,60	0,15 - 0,25	20 - 100						on request		0,30 - 0,60	
		21,61 - 39,60	0,20 - 0,40									0,40 - 1,00	
		39,61 - 40,60	0,30 - 0,40									0,40 - 1,00	
Titanium and alloys		11,80 - 21,60	0,15 - 0,25	6 - 10	15 - 30							0,20 - 0,40	
		21,61 - 39,60	0,20 - 0,40									0,30 - 0,50	
		39,61 - 40,60	0,30 - 0,40									0,40 - 0,60	

APPROACH ANGLES

MATERIAL TO WORK	TENSILE STRENGTH	APPROACH ANGLE*
Iron and mild steel (C < 0,2%)	50 Kg/mm ²	G - A - E
Mild steel (C 0,2 < 0,3%)	60 Kg/mm ²	N - A - E
Mild steel (C 0,3 < 0,4%)	70 Kg/mm ²	N - A - E
Mild steel (C 0,4 < 0,5%)	80 Kg/mm ²	N - A - E
Alloy steel	≤ 80 Kg/mm ²	G - N - A - E
Alloy steel	90 Kg/mm ²	G - N - E
Alloy steel	100 Kg/mm ²	G - N - M
Alloy steel	> 100 Kg/mm ²	G - N - M
Stainless and refractory steel	from 50 Kg/mm ² to 90 kg/ mm ²	G - N - M
Grey, spheroidal and malleable cast iron	from 150 HB to 320 HB	V - N - E
Titanium and titanium alloy		T - E
Pure copper		G - N - E
Electrolytic copper		G - N - E
Brass / Bronze		G - N - E
Aluminium alloy < 10% Si		V - A - E
Aluminium alloy > 11% Si		V - E
Magnesium alloy		G - A - E
Thermoplastic material		V - E
Thermosetting resins		V - E
Stiffened synthetic material		V - E

*Do not use negative lead-in on blind holes

Negative lead-in "N" can be used on large range of materials: please apply to our technical department.

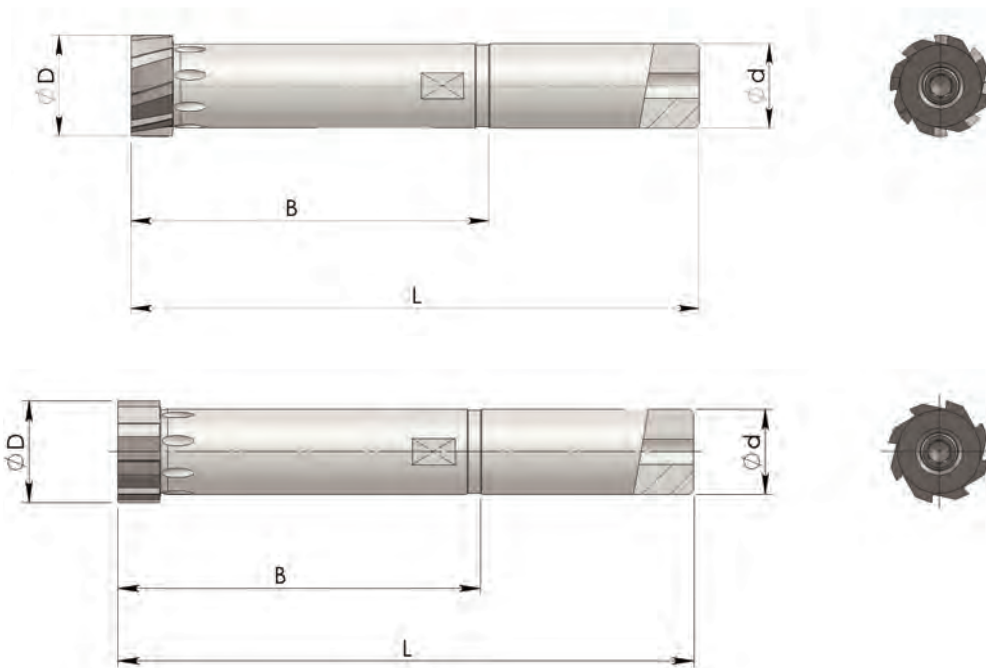

Head Mandrel - Short Series 9000-MC

Mandrel Code*	Ø D (mm)	B (mm)	L (mm)	Ød h6 (mm)	Locking screw through holes	Locking screw blind hole
9000-MC-001	11,80÷14,60	50	95	12	9000-VI-001	9001-VI-001
9000-MC-002	14,61÷17,60	65	113	16	9000-VI-002	9001-VI-002
9000-MC-003	17,61÷21,60	75	125	20	9000-VI-003	9001-VI-003
9000-MC-004	21,61÷26,60	85	135	20	9000-VI-004	9001-VI-004
9000-MC-005	26,61÷32,60	105	161	25	9000-VI-005	9001-VI-005
9000-MC-006	32,61÷36,60	120	180	32	9000-VI-006	9001-VI-006
9000-MC-007	36,61÷40,60	120	180	32	9000-VI-006	9001-VI-006

Head Mandrel - Long Series 9000-ML

Mandrel Code*	Ø D (mm)	B (mm)	L (mm)	Ød h6 (mm)	Locking screw through holes	Locking screw blind hole
9000-ML-001	11,80÷14,60	95	140	12	9000-VI-001	9001-VI-001
9000-ML-002	14,61÷17,60	105	153	16	9000-VI-002	9001-VI-002
9000-ML-003	17,61÷21,60	125	175	20	9000-VI-003	9001-VI-003
9000-ML-004	21,61÷26,60	145	195	20	9000-VI-004	9001-VI-004
9000-ML-005	26,61÷32,60	165	221	25	9000-VI-005	9001-VI-005
9000-ML-006	32,61÷36,60	185	245	32	9000-VI-006	9001-VI-006
9000-MC-007	36,61÷40,60	185	245	32	9000-VI-006	9001-VI-006

Mandrel code without head and locking screw, they must be ordered separately.

Note:

- All mandrels are provided with radial tool coolant, suitable for working through holes.
- To ream blind holes is recommended to order their respective drilled screw that allows only axial coolant flow.
- Both types of screw do not protrude the head.
- Therefore, also the screw for through holes allows to ream counterborings.

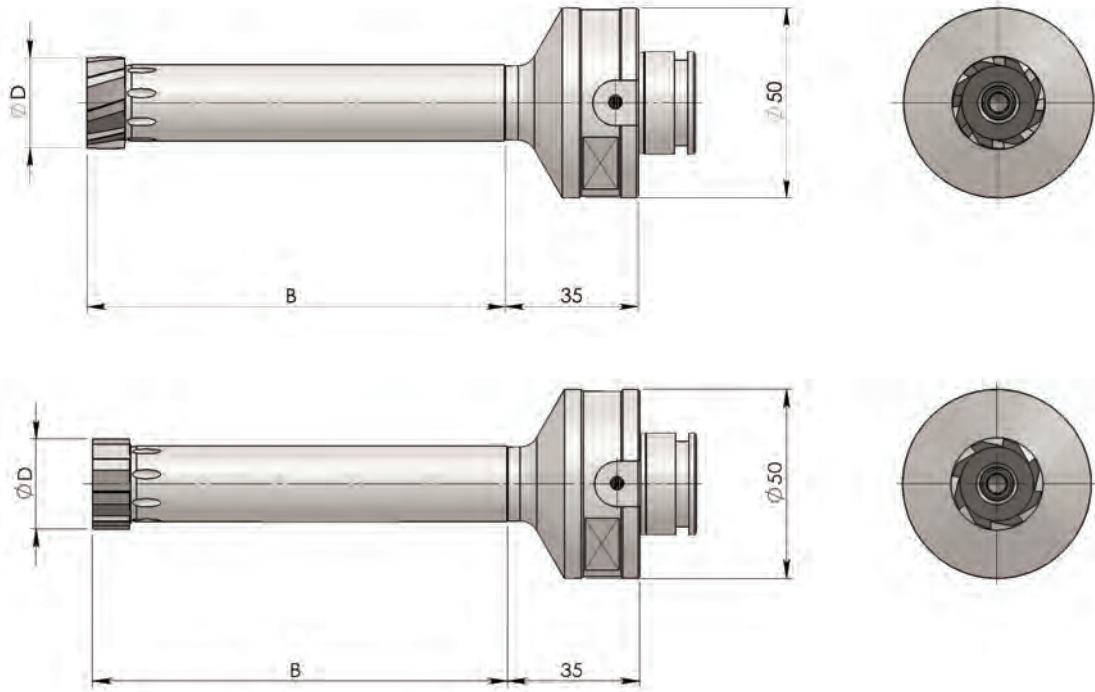

Short Series 9000-MM

Mandrel Code*	Ø D (mm)	B (mm)	Locking screw through holes	Locking screw blind hole
9000-MM-001	11,80 ÷ 14,60	65	9000-VI-001	9001-VI-001
9000-MM-002	14,61 ÷ 17,60	80	9000-VI-002	9001-VI-002
9000-MM-003	17,61 ÷ 21,60	100	9000-VI-003	9001-VI-003
9000-MM-004	21,61 ÷ 26,60	110	9000-VI-004	9001-VI-004
9000-MM-005	26,61 ÷ 32,60	120	9000-VI-005	9001-VI-005
9000-MM-006	32,61 ÷ 36,60	120	9000-VI-006	9001-VI-006
9000-MM-007	36,61 ÷ 40,60	120	9000-VI-006	9001-VI-006

* Mandrel code without head and locking screw, they have to be ordered separately.

Note:

- All mandrels are provided with radial tool coolant, suitable for working through holes.
- To ream blind holes is recommended to order their respective drilled screw that allows only axial coolant flow.
- Both types of screw do not protrude the head.
- Therefore, also the screw for through holes allows to ream counterborings.

RECOMMENDED VALUES FOR LUBRICANTS

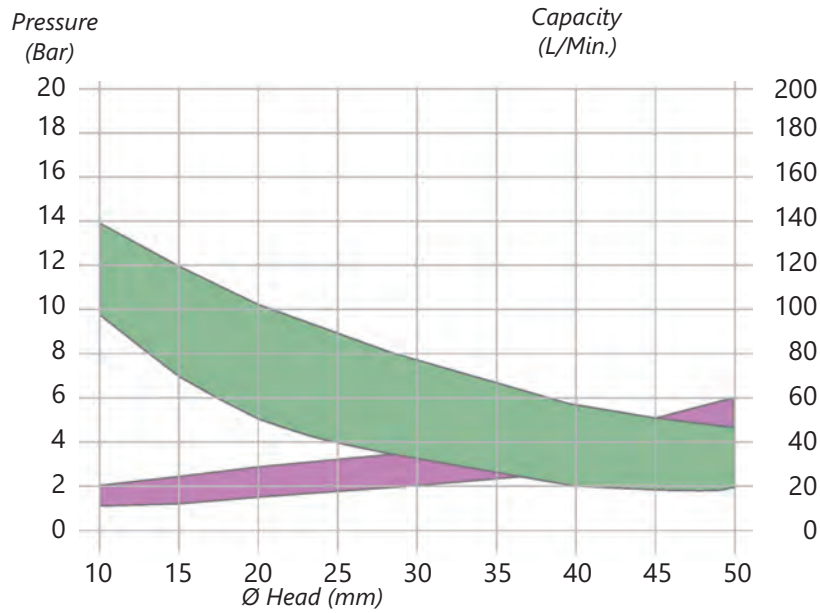

It is important to use a good quality lubricant.

LOCKING SCREW TORQUES

Diameter	Nm
11,80 ÷ 14,60	2.5
14,61 ÷ 17,60	3.5
17,61 ÷ 21,60	4.5
21,61 ÷ 26,60	6
26,61 ÷ 32,60	10
32,61 ÷ 40,60	12

INSTRUCTIONS TO ASSEMBLY

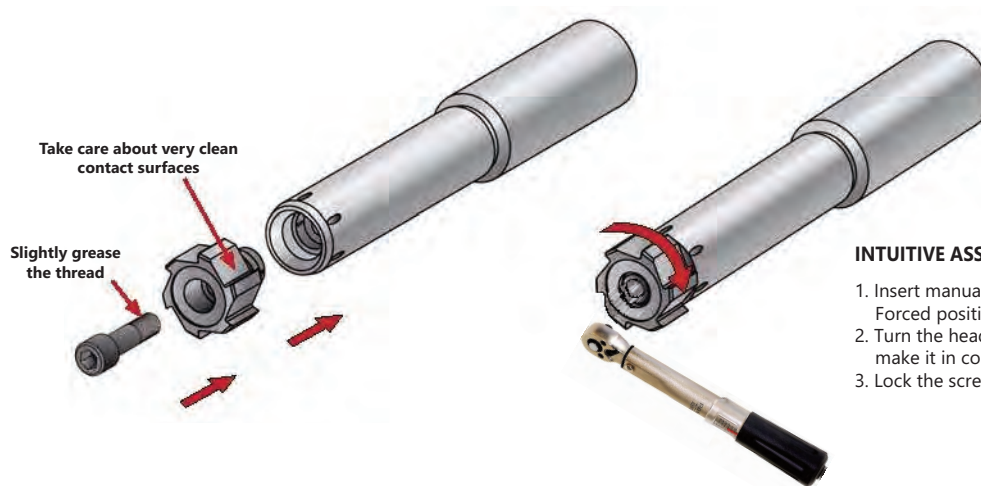

INTUITIVE ASSEMBLY

1. Insert manually the head in the slot. Forced position allows to make it easy
2. Turn the head clockwise few degrees to make it in contact with mandrel surface.
3. Lock the screw handling a dynamometric key.

Modular System



Features & Benefits

- Large range of shanks for different machine types
- Highly adjustable for improved concentricity
- All shanks are available with through coolant

BASIC SHANKS DIN 69871/1 B+A ^[1]

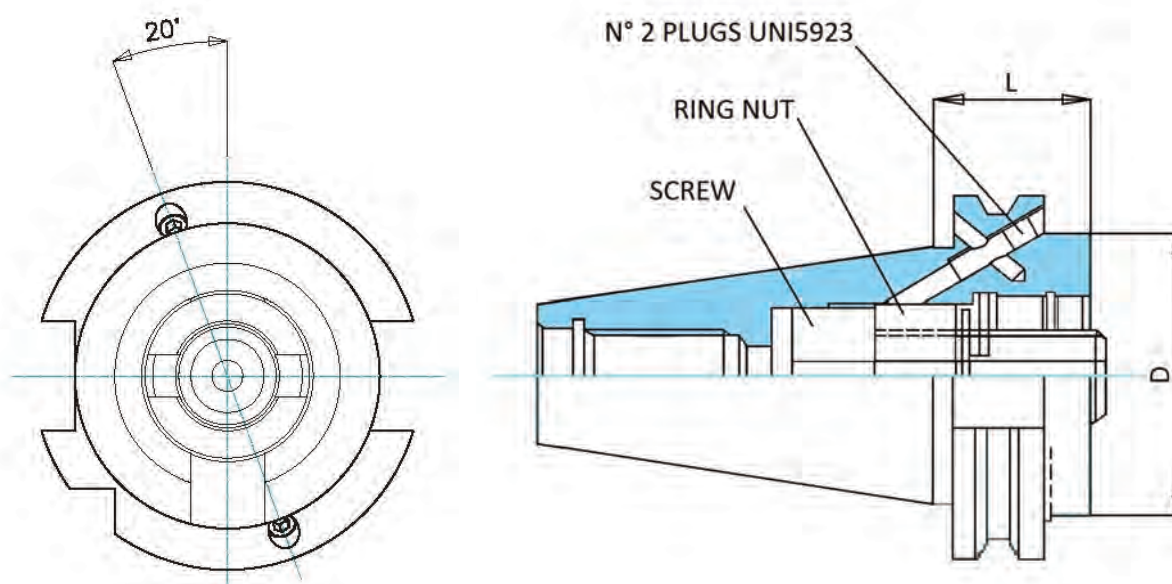

ORDER CODE	ISO	MODULAR REDUCER D	L	STANDARD EQUIPMENT			ACCESSORIES	
				screw	ring nut	plugs	modular screw key	modular ring nut key
02B.40.50.27	40	50	27	TAB2808	TAB2809	M5X5TG	hexagon 10	ATR8851
02B.40.63.50	40	63	50	TAB9038	TAB2793	M5X5TG	hexagon 12	ATR8851
02B.40.80.50	40	80	50	TAB9038	TAB2793	M5X5TG	hexagon 12	ATR8851
02B.45.50.27	45	50	27	TAB2808	TAB2809	M5X5TG	hexagon 10	ATR8851
02B.45.63.27	45	63	27	TAB2795	TAB2793	M5X5TG	hexagon 14	ATR8851
02B.45.63.50	45	63	50	TAB2795	TAB2793	M5X5TG	hexagon 14	ATR8851
02B.45.80.50	45	80	50	TAB2795	TAB2793	M5X5TG	hexagon 14	ATR8851
02B.50.50.27	50	50	27	TAB2808	TAB2809	M5X5TG	hexagon 10	ATR8851
02B.50.50.50	50	50	50	TAB2808	TAB2809	M5X5TG	hexagon 10	ATR8851
02B.50.63.27	50	63	27	TAB2795	TAB2793	M5X5TG	hexagon 14	ATR8851
02B.50.63.50	50	63	50	TAB2795	TAB2793	M5X5TG	hexagon 14	ATR8851
02B.50.80.27	50	80	27	TAB2795	TAB2793	M5X5TG	hexagon 14	ATR8851
02B.50.80.50	50	80	50	TAB2795	TAB2793	M5X5TG	hexagon 14	ATR8851

^[1] Basic shanks can be converted into DIN 69871/1A coolant by screwing the two plugs clockwise to the end of their stroke.

BASIC SHANKS DIN 69871/1 B + A ^[1] MODULAR WITH LATERAL CLAMPING ^[2] AND RADIAL ADJUSTMENT

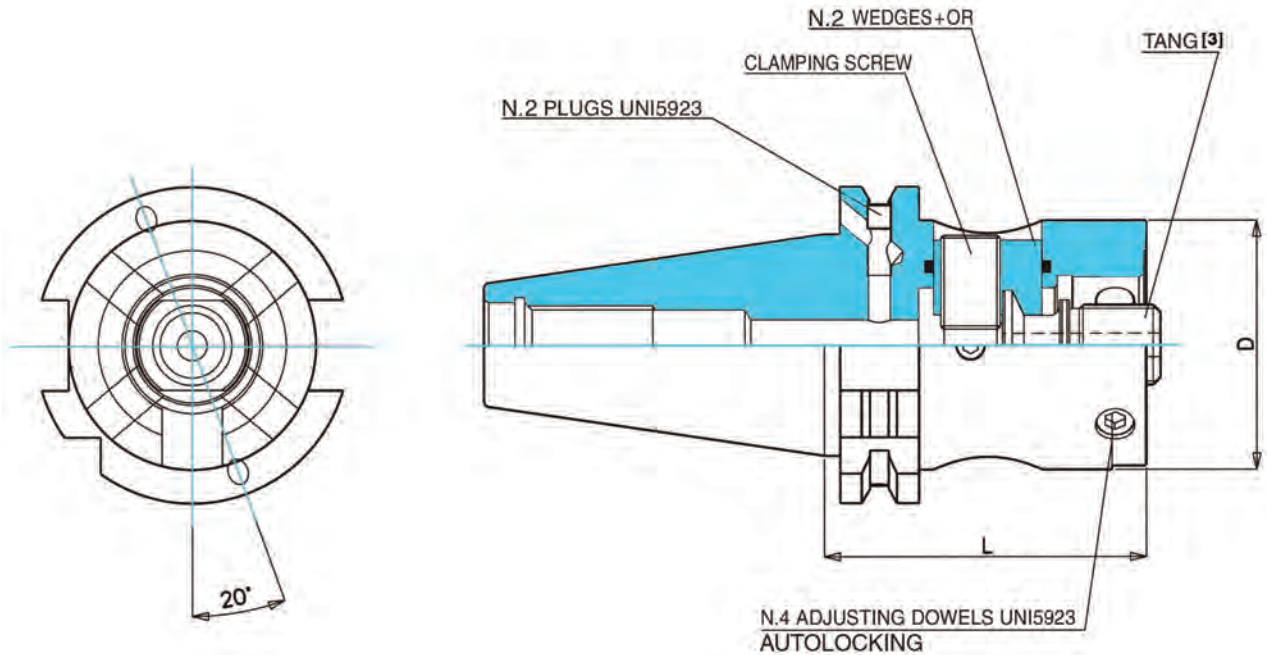

ORDER CODE	ISO	MODULAR REDUCER D	L	STANDARD EQUIPMENT					ACCESSORIES	
				wedges+OR	clamping screw	adjusting dowels	plugs	TANG ^[3]	clamping screw key	tang key
02B.40.50L.65	40	50	65	ATR14102.2.3	ATR14102.1	M8x1x10G	M5x5TG	ATT14103	hexagon 6	fixed 18
02B.40.63L.85	40	63	85	ATR14108.2.3	ATR14108.1	M8x1x14G	M5x5TG	ATT14104	hexagon 6	fixed 24
02B.45.50L.70	45	50	70	ATR14102.2.3	ATR14102.1	M8x1x10G	M5x5TG	ATT14103	hexagon 6	fixed 18
02B.45.63L.70	45	63	70	ATR14108.2.3	ATR14108.1	M8x1x14G	M5x5TG	ATT14104	hexagon 6	fixed 24
02B.50.50L.70	50	50	70	ATR14102.2.3	ATR14102.1	M8x1x10G	M5x5TG	ATT14103	hexagon 6	fixed 18
02B.50.63L.70	50	63	70	ATR14108.2.3	ATR14108.1	M8x1x14G	M5x5TG	ATT14104	hexagon 6	fixed 24
02B.50.80L.70	50	80	70	ATR18775.2.3	ATR18775.1	M8x1x20G	M5x5TG	ATT14104	hexagon 6	fixed 24

^[1] Basic shanks can be converted into DIN 69871/1A coolant by screwing the two plugs clockwise to the end of their stroke.

^[2] The modular system has lateral clamping which enables efficient quick release of the tools. Light torque exerted on the clamping screw transmits high axial forces which provide stiffness and extreme accuracy to the assembly.

^[3] All adaptors and tools with modular shanks require their respective tang fitted before assembly to the system with lateral clamping.

BASIC SHANKS JMTBA MAS-403 BT B+BT^[1]

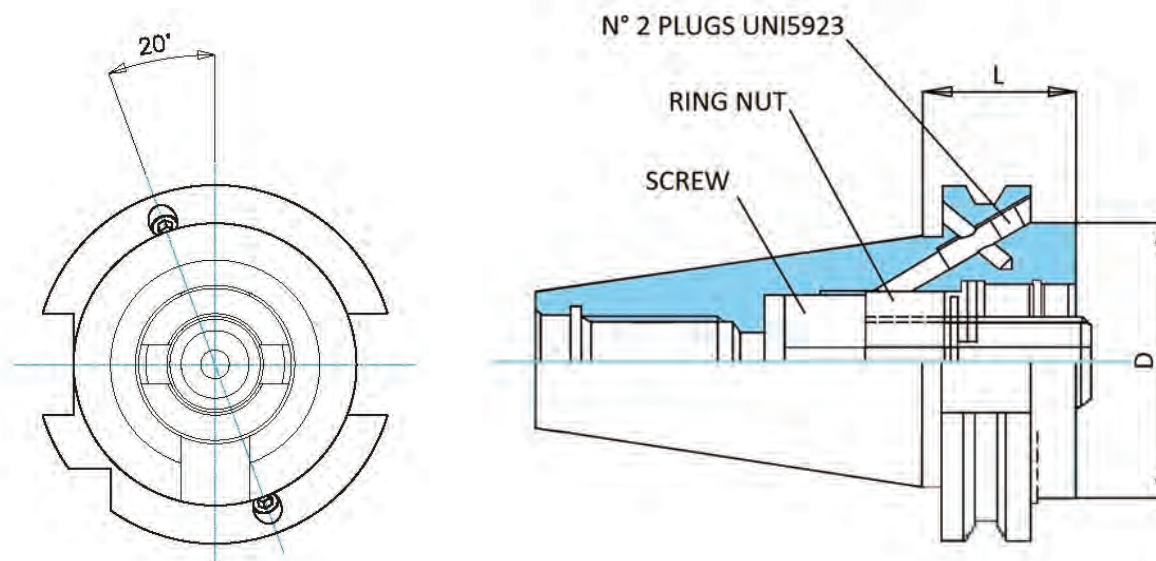

ORDER CODE	BT	MODULAR REDUCER D	L	STANDARD EQUIPMENT			ACCESSORIES	
				screw	ring nut	plugs	modular screw key	modular ring nut key
BTB.40.50.50	40	50	50	TAB2808	TAB2809	M5X5TG	hexagon 10	ATR8851
BTB.40.63.50	40	63	50	TAB9038	TAB2793	M5X5TG	hexagon 12	ATR8851
BTB.50.50.50	50	50	50	TAB2808	TAB2809	M5X5TG	hexagon 10	ATR8851
BTB.50.63.50	50	63	50	TAB2795	TAB2793	M5X5TG	hexagon 14	ATR8851
BTB.50.80.50	50	80	50	TAB2795	TAB2793	M5X5TG	hexagon 14	ATR8851

^[1] Basic shanks can be converted into MAS-403 BT coolant by screwing the two plugs clockwise to the end of their stroke.

BASIC SHANKS JMTBA MAS-403 BT B+BT ^[1] MODULAR WITH LATERAL CLAMPING ^[2] AND RADIAL ADJUSTMENT

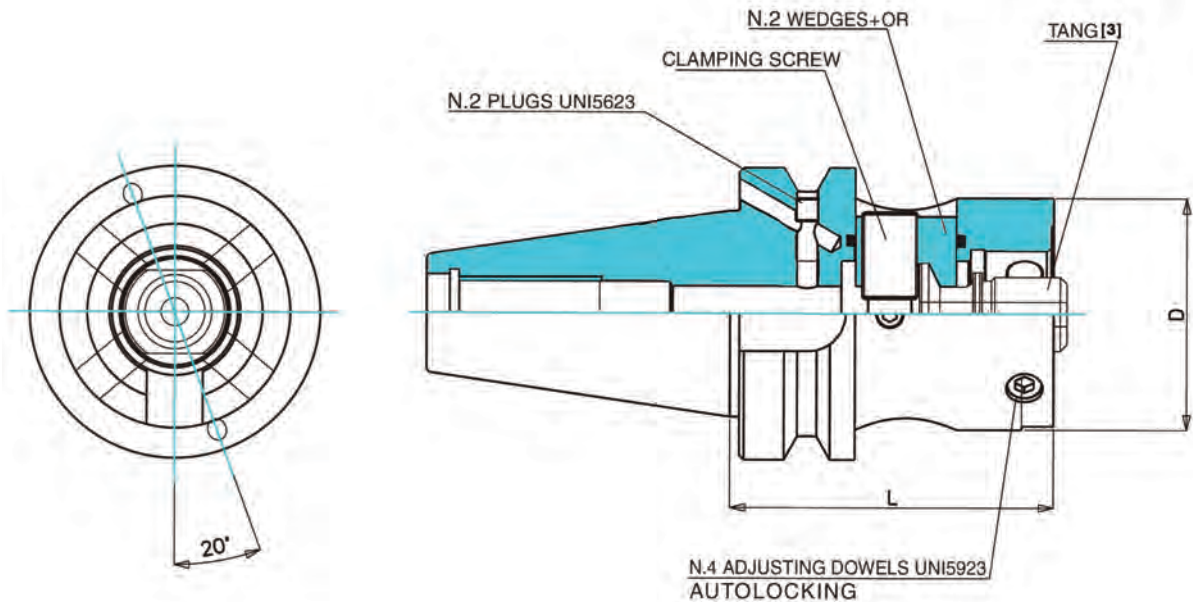

Max radial adjustment : +/- 0,2 mm on Ø

ORDER CODE	BT	MODULAR REDUCER D	L	STANDARD EQUIPMENT					ACCESSORIES	
				wedges+OR	clamping screw	adjusting dowels	plugs	TANG ^[3]	clamping screw key	tang key
BTB.40.50L.70	40	50	70	ATR14102.2.3	ATR14102.1	M8x1x10G	M5x5TG	ATT14103	hexagon 6	fixed 18
BTB.40.63L.80	40	63	80	ATR14108.2.3	ATR14108.1	M8x1x14G	M5x5TG	ATT14104	hexagon 6	fixed 24
BTB.50.50L.90	50	50	90	ATR14102.2.3	ATR14102.1	M8x1x10G	M5x5TG	ATT14103	hexagon 6	fixed 18
BTB.50.63L.90	50	63	90	ATR14108.2.3	ATR14108.1	M8x1x14G	M5x5TG	ATT14104	hexagon 6	fixed 24
BTB.50.80L.90	50	80	90	ATR18775.2.3	ATR18775.1	M8x1x20G	M5x5TG	ATT14104	hexagon 6	fixed 24

^[1] Basic shanks can be converted into DIN 69871/1A coolant by screwing the two plugs clockwise to the end of their stroke.

^[2] The modular system has lateral clamping which enables efficient quick release of the tools. Light torque exerted on the clamping screw transmits high axial forces which provide stiffness and extreme accuracy to the assembly.

^[3] All adaptors and tools with modular shanks require their respective tang fitted before assembly to the system with lateral clamping.

BASIC SHANKS HSK-A DIN 69893/1

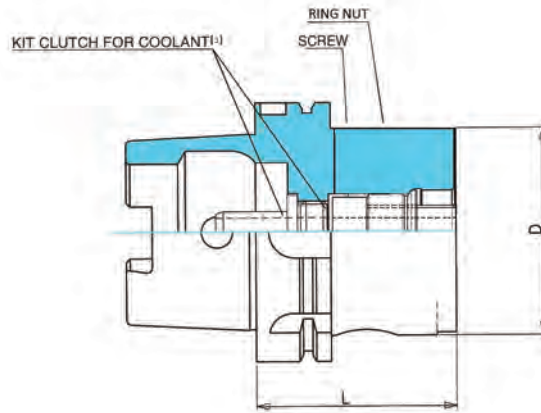

ORDER CODE	HSK	MODULAR REDUCER D	L	STANDARD EQUIPMENT		ACCESSORIES			
				screw	ring nut	modular screw key	modular ring nut key	key kit clutch for coolant	kit clutch for coolant ^[1]
HSK-A.63.50.75	63	53	75	TAB2808	TAB2809	hexagon 10	ATR8851	ATR23856	ATT23728
HSK-A.63.63.85	63	63	85	TAB2795	TAB2793	hexagon 14	ATR8851	ATR23856	ATT23728
HSK-A.100.50.80	100	50	80	TAB2808	TAB2809	hexagon 10	ATR8851	ATR23856	ATT23656
HSK-A.100.63.90	100	63	90	TAB2795	TAB2793	hexagon 14	ATR8851	ATR23856	ATT23656
HSK-A.100.80.90	100	80	90	TAB2795	TAB2793	hexagon 14	ATR8851	ATR23856	ATT23656

^[1] coolant clutch kits are supplied separately on request

ADJUSTING CYLINDRICAL BASIC SHANKS

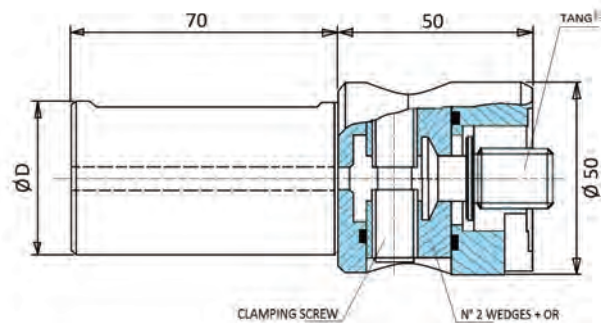

ORDER CODE	D	STANDARD EQUIPMENT				ACCESSORIES	
		wedges+OR	clamping screw	adjusting dowels	TANG ^[3]	tang key	clamping screw key
CIL.25.50.50	25	ATR14102.2.3	ATR14102.1	M8x1x10G	ATT14103	fixed 18	hexagon 6
CIL.32.50.50	32	ATR.14102.2.3	ATR14102.1	M8x1x10G	ATT14103	fixed 18	hexagon 6
CIL.40.50.50	40	ATR14102.2.3	ATR14102.1	M8x1x10G	ATT14103	fixed 18	hexagon 6

BASIC SHANKS HSK-A DIN 69893/1 MODULAR WITH LATERAL CLAMPING ^[1] AND RADIAL ADJUSTMENT

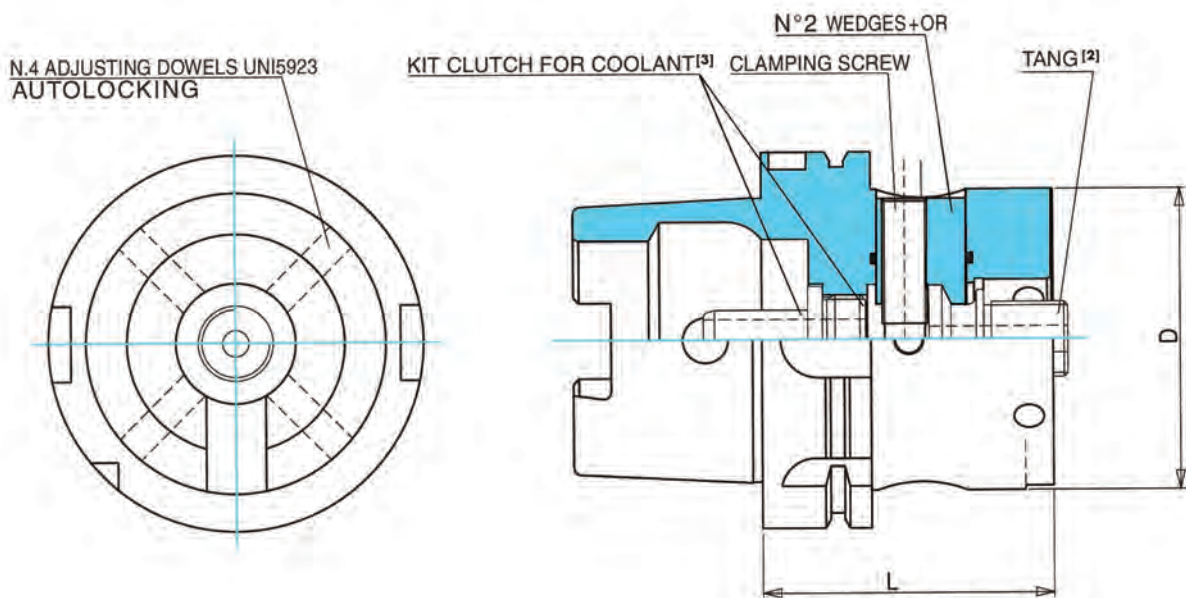

Max radial adjustment : +/- 0,2 mm on Ø

ORDER CODE	HSK	MODULAR REDUCER D	L	STANDARD EQUIPMENT			ACCESSORIES				
				wedges+OR	clamping screw	adjusting dowels	clamping screw key	tang key ^[2]	key kit clutch for coolant	kit clutch for coolant ^[3]	
HSK-A.63.50L.70	63	50	70	ATR14102.2.3	ATR14102.1	M8x1x10G	hexagon 6	fixed 18	ATT14103	ATR23856	ATT23728
HSK-A.63.63L.75	63	63	75	ATR41613.4	ATR14108.1	M8x1x14G	hexagon 6	fixed 24	ATT14104	ATR23856	ATT23728
HSK-A.100.50L.80	100	50	80	ATR14102.2.3	ATR14102.1	M8x1x10G	hexagon 6	fixed 18	ATT14103	ATR23856	ATT23656
HSK-A.100.63L.80	100	63	80	ATR14108.2.3	ATR14108.1	M8x1x14G	hexagon 6	fixed 24	ATT14104	ATR23856	ATT23656
HSK-A.100.80L.80	100	80	80	ATR18775.2.3	ATR18775.1	M8x1x20G	hexagon 6	fixed 24	ATT14104	ATR23856	ATT23656

^[1] The modular system has lateral clamping which enables efficient quick release of the tools. Light torque exerted on the clamping screw transmits high axial forces which provide stiffness and extreme accuracy to the assembly.

^[2] All adaptors and tools with modular shanks require their respective tang fitted before assembly to the system with lateral clamping.

^[3] Coolant clutch kits are supplied separately on request.

MODULAR EXTENSION

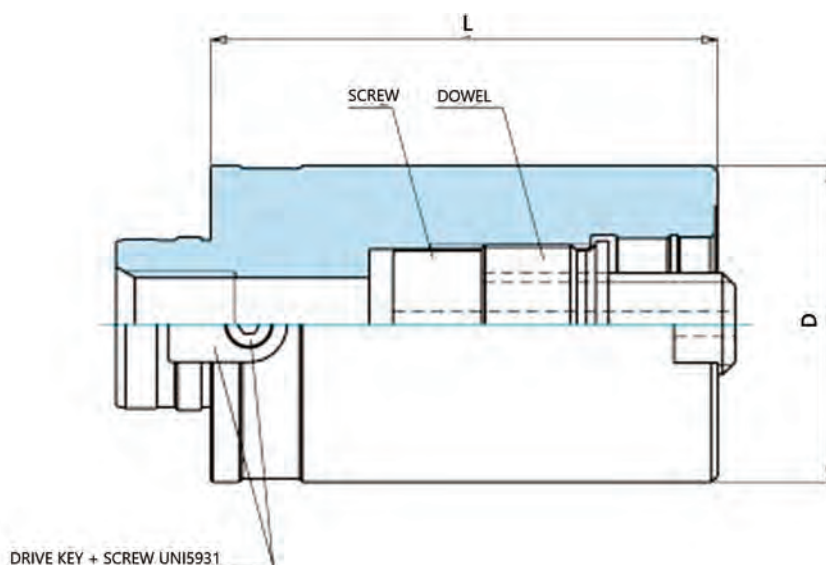

ORDER CODE	MODULAR SHANK D	L	STANDARD EQUIPMENT				ACCESSORIES	
			screw	ring nut	drive key	dowel	ring nut key	adjusting dowel key
10.19.19.50	19	50	TAB23830	TAB23829	TAB23831	M2X4V	ATR23502	hexagon 4
10.19.19.120	19	120	TAB23830	TAB23829	TAB23831	M2X4V	ATR23502	hexagon 4
10.24.24.50	24	50	TAB23501	TAB23500	TAB23499	M3X5V	ATR23502	hexagon 5
10.24.24.120	24	120	TAB23501	TAB23500	TAB23499	M3X5V	ATR23502	hexagon 5
10.32.32.40	32	40	TAB12608	-	TAB12594.1	M4X6V	-	hexagon 6
10.32.32.60	32	60	TAB12592	TAB12593	TAB12594.1	M4X6V	ATR12605	hexagon 6
10.32.32.150	32	150	TAB12592	TAB12593	TAB12594.1	M4X6V	ATR12605	hexagon 6
10.40.40.40	40	40	TAB12609	-	TAB12594.2	M4X6V	-	hexagon 8
10.40.40.60	40	60	TAB12584	TAB12585	TAB12594.2	M4X6V	ATR12605	hexagon 8
10.50.50.30	50	30	TAB23205	-	TAB3924	M4X8V	-	hexagon 10
10.50.50.60	50	60	TAB2808	TAB2809	TAB3924	M4X8V	ATR8851	hexagon 10
10.50.50.100	50	100	TAB2808	TAB2809	TAB3924	M4X8V	ATR8851	hexagon 10
10.63.63.40*	63	40	TAB9041	-	TAB3923.1	M6X12V	-	hexagon 14
10.63.63.80	63	80	TAB2795	TAB2793	TAB3923.1	M6X12V	ATR8851	hexagon 14
10.63.63.120	63	120	TAB2795	TAB2793	TAB3923.1	M6X12V	ATR8851	hexagon 14
10.80.80.40*	80	40	TAB9041	-	TAB3923.2	M6X16V	-	hexagon 14
10.80.80.80	80	80	TAB2795	TAB2793	TAB3923.2	M6X16V	ATR8851	hexagon 14
10.80.80.120	80	120	TAB2795	TAB2793	TAB3923.2	M6X16V	ATR8851	hexagon 14
10.80.80.160	80	160	TAB2795	TAB2793	TAB3923.2	M6X16V	ATR8851	hexagon 14

*To assembly this type of modular extension directly on the modular ISO40/BT40 you should order the screw TAB13913 with hexagon 12.

COLLET CHUCK ADAPTORS ERC DIN 6499-B FOR SHANKS WITH RADIAL ADJUSTMENT

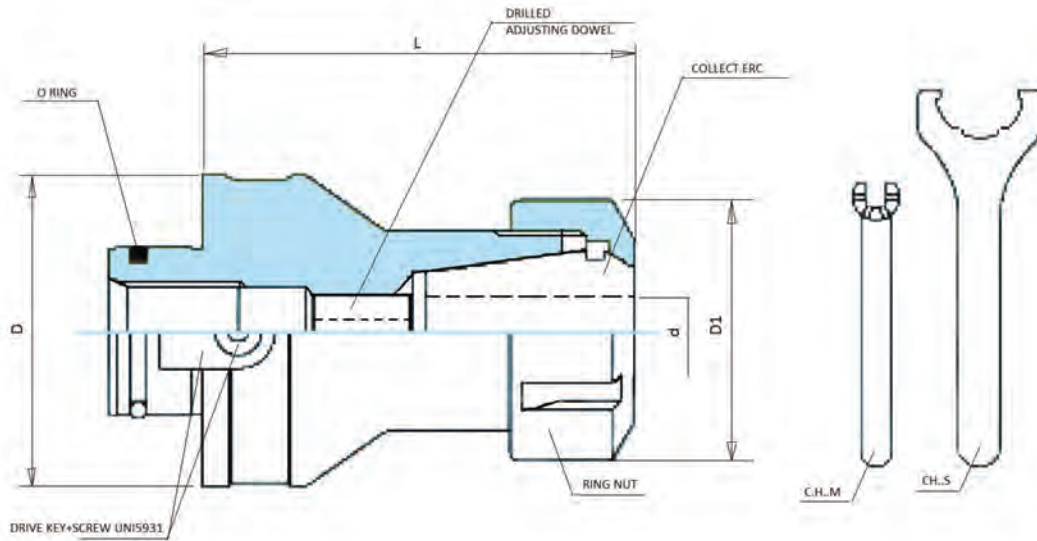

ORDER CODE	MODULAR SHANK D	COLLECT REDUCER	d	D1	L	STANDARD EQUIPMENT					ACCESSORIES	
						ring nut	drive key	screw	dowel	O ring	ring nut key	adjusting dowel key
30.50R.25.70	50	ERC25	0.5÷16	42	70	G25S	TAB3924	M4x8V	M12x16GF	130	CH25S	hexagon 6
30.50R.32.70	50	ERC32	1÷20	50	70	G32S	TAB3924	M4x8V	M16x15x18GF	130	CH32S	hexagon 8
30.63R.32.90	63	ERC32	1÷20	50	90	G32S	TAB3923.1	M6x12V	M12x16GF	1400	CH32S	hexagon 6
30.63R.40.90	63	ERC40	2÷30	63	90	G40S	TAB3923.1	M6x12V	M20x2x20GF	1400	CH40S	hexagon 10
30.80R.32.90	80	ERC32	1÷20	50	90	G32S	TAB3923.2	M6x16V	M12x16GF	1400	CH32S	hexagon 6
30.80R.40.90	80	ERC40	2÷30	63	90	G40S	TAB3923.2	M6x16V	M20x2x20GF	1400	CH40S	hexagon 10

OPERATING INSTRUCTIONS FOR LATERAL MODULAR SHANK

- Remove the tang from the lateral modular shank by loosening the clamping screw.
- Assemble the tang to the adaptor spigot which matches the lateral modular shank.
- Insert the adaptor with its tang into the reducer bore of the lateral modular shank.
- Lock the adaptor by tightening the clamping screw.

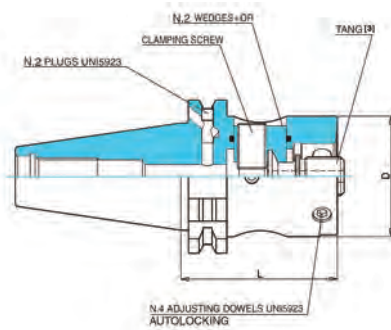

ASSEMBLY FOR RADIAL ADJUSTING

Note: Only adaptors with modular reducer spigot are suitable for radial adjustment

Complete the operations mentioned above then proceed as follows:

- Lightly tighten the clamping screw so that the tang is still able to move in a radial direction.
- Correct eccentricity with the 4 adjusting dowels by bringing them into contact with the tang
- Tighten the clamping screw to lock the tang.
- Re-check for eccentricity, if required use the 4 adjusting dowels to correct and restore the value.
- Tighten the clamping screw to lock the adaptor.

N.B. Do not operate on items marked with red paint.

Setup Instructions & Practical Suggestions



EXPANDING & FIXED REAMERS

1) Diameter measurement

The diameter of the reamers and of the cutting rings is measured with a micrometer. We recommend the use of a comparator style micrometer with a least a 2 μm resolution to avoid micro chipping of the cutting edges.

To allow setting of the reamer, two cutting edges are exactly 180° opposed. These are marked with a dimple (see diagram below).

Measurement must be taken from the front of the cutting edges only.

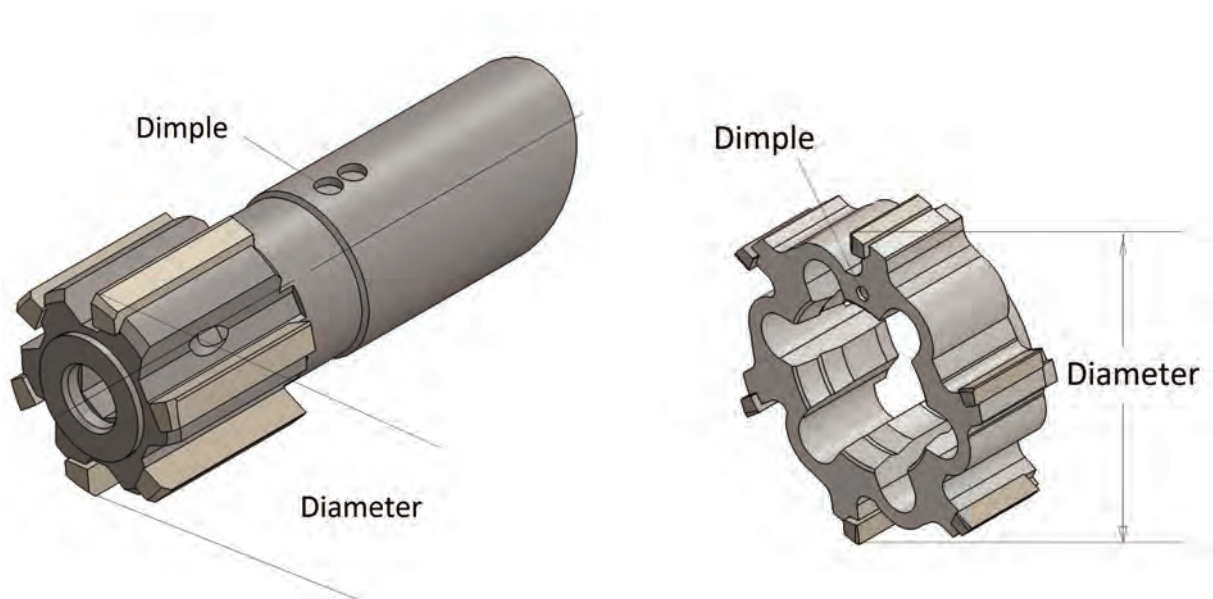

2) Tolerance

Expandible reamer are ground to the middle of the tolerance.

Fixed reamer are ground at the $2/3$ of the tolerance.

3) Expanding reamers adjustment

The adjustment must be made to compensate for wear to the cutting edges when the size reaches its lower tolerance.

This operation can be repeated several times until the surface finish of the hole deteriorates to an unacceptable level, then the reamer must be reground.

ASSEMBLY - ADJUSTMENT - DISASSEMBLY

Series 2431 - 2441 - 3610 - 3617 - 3620 - 3627
from Ø 5,80 to Ø 32,10 mm

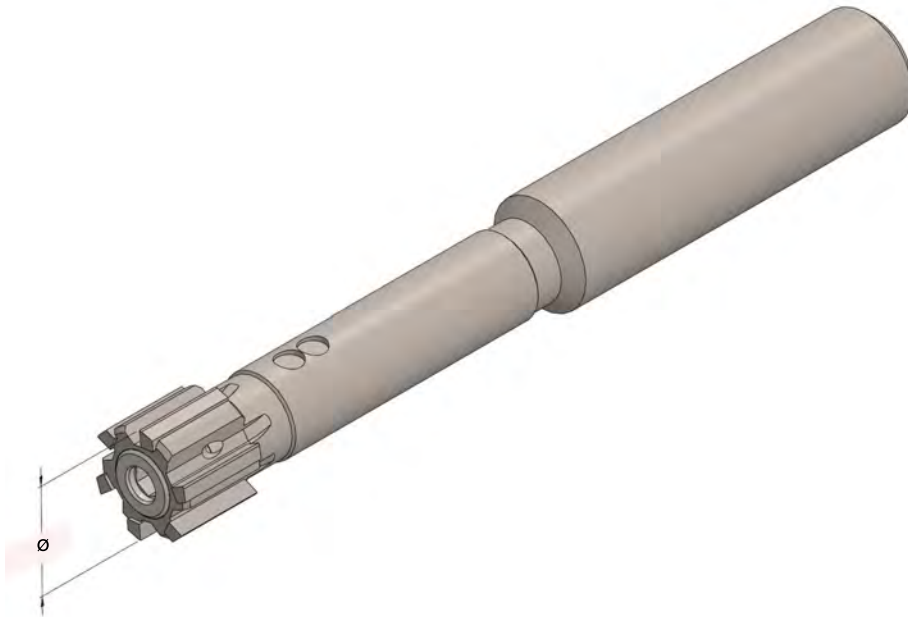

1) Adjustment procedure

Turn the **right hand threaded** screw slowly clockwise, while checking the diameter setting of the reamer with a micrometer.

When the required diameter is achieved, the tool is ready for use.

ASSEMBLY - ADJUSTMENT - DISASSEMBLY EXPANDING REAMERS WITH CUTTING RING with assembly and adjustment in the front

Series 4500 - 4500A - 4550 - 4550A
from Ø 17,60 to Ø 100,59 mm

Series 4350 - 4330
from Ø 17,60 to Ø 100,59 mm

Series 4300
from Ø 17,60 to Ø 100,59 mm

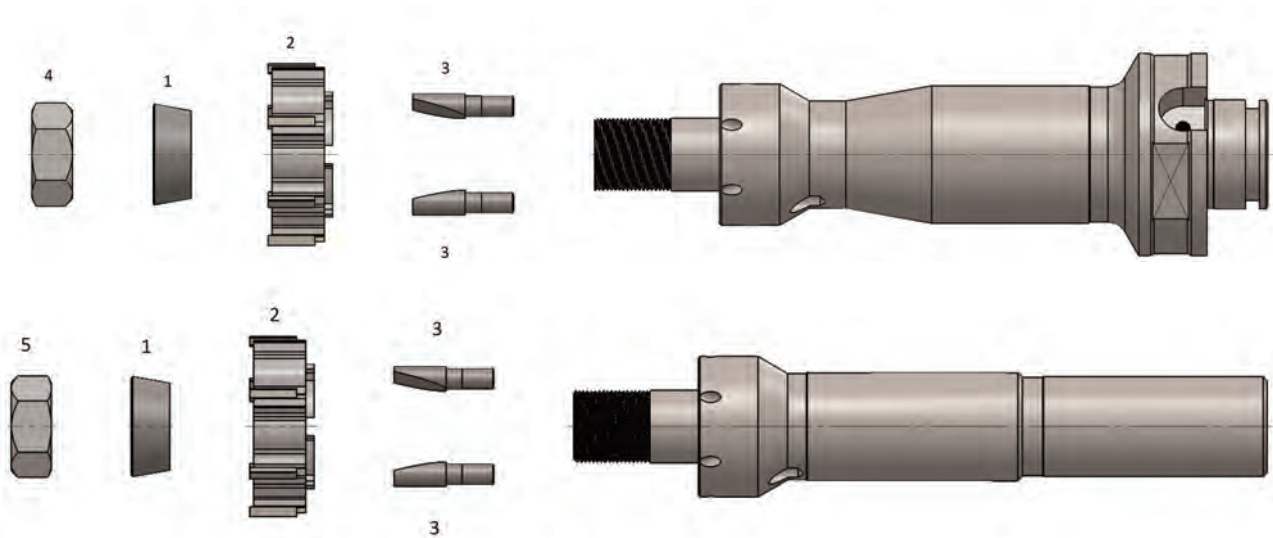

1) Assembly

Insert the cutting ring (item 2) on the mandrel with the drive pins (item 3) assembled. Insert the conical ring (item 1). Screw the nut (item 5) and lock in manually: the thread is left handed.

We recommend lubricating the thread and the conical surface of contact between the cutting ring and the conical ring with antifriction Molycote grease.

2) Adjustment procedure

Turn the nut slowly, checking the diameter setting of the cutting ring with a micrometer, paying attention that the drive pins are in traction in the opposite direction to the cutting action of the reamer.

When the required diameter is achieved, the tool is ready for use.

3) Disassembly

Unscrew the nut.

Remove the components from the mandrel.

ASSEMBLY - ADJUSTMENT - DISASSEMBLY EXPANDING REAMERS WITH CUTTING RING with assembly and adjustment in the front

Series 4505 - 4505A - 4555 - 4555A -
from Ø 17,60 to Ø 100,59 mm

Series 4305 - 4355 - 4335
from Ø 17,60 to Ø 100,59 mm

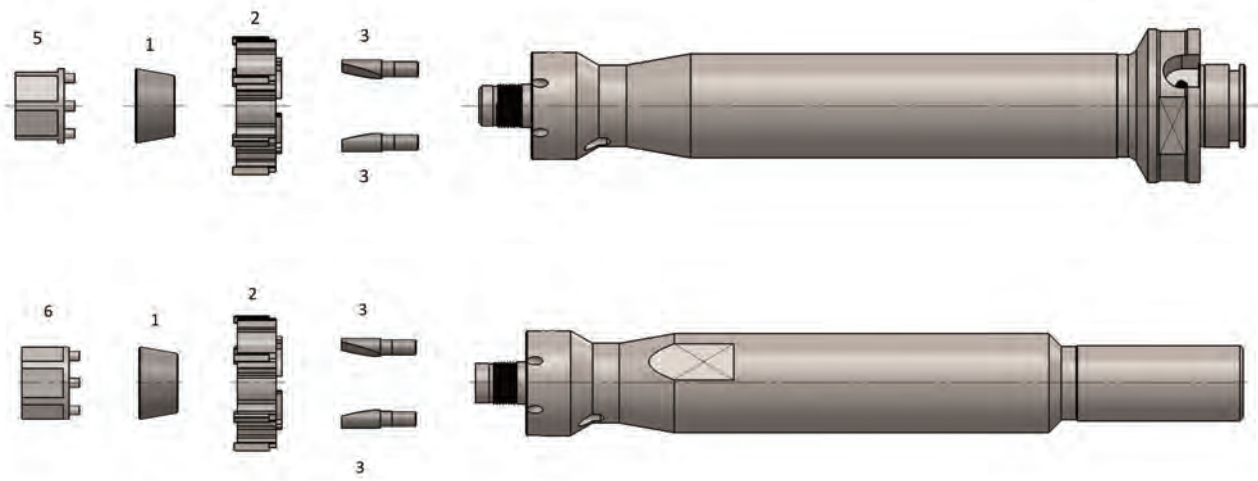

1) Assembly

Mount the cutting ring (item 2) onto the mandrel with the drive pins (item 3) assembled. Screw the conical ring nut onto the mandrel and lock it manually: **the thread is left handed**. Lubricate the thread and the conical surface of contact between the cutting ring and the conical ring with antifriction Molycote grease.

2) Adjustment procedure

Turn the conical ring nut slowly using a pin spanner (item 6) supplied with reamers from diameter 17,60 to 40,59 mm, checking the diameter setting of the cutting ring with a micrometer.

When the required diameter is achieved unscrew the conical ring until there is a click and the drive pins are in traction in the opposite direction to the cutting action of the reamer. The reamer is ready for use.

3) Disassembly

Unscrew the conical ring nut.
Remove the components from the mandrel.

ASSEMBLY - ADJUSTMENT - DISASSEMBLY EXPANDING REAMERS WITH CUTTING RING with assembly and adjustment in the front

Series 4350
from Ø 100,60 to Ø 200,59 mm

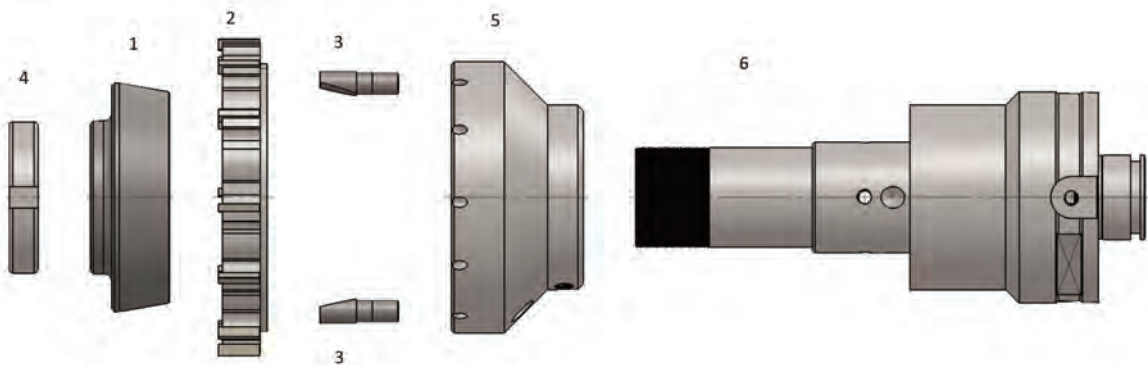

1) Assembly

With the drive pins (item 3) assembled, mount the flange (item 5) onto the mandrel (item 6).

Assemble the cutting ring (item 2) so that the slot on the left side of the dimple is mounted onto the drive pins. Insert the conical ring (item 1).

Screw the ring nut (item 4) onto the mandrel and tighten manually, so that the conical ring makes contact with the cutting ring: the thread is left handed.

We recommend lubricating the thread and the conical surface of contact between the cutting ring and the conical ring with antifriction Molycote grease.

2) Adjustment procedure

Turn the ring nut slowly (using a pin spanner) checking the diameter setting of the cutting ring with a micrometer, paying attention that the drive pins are in traction, in the opposite direction to the cutting action of reamer.

When the required diameter is achieved, the tool is ready for use.

3) Disassembly

Unscrew the ring nut.

Remove the components from the mandrel.

ASSEMBLY - ADJUSTMENT - DISASSEMBLY EXPANDING REAMERS WITH CUTTING RING with assembly and adjustment in the front

Series 4355
from Ø 100,60 to Ø 200,59 mm

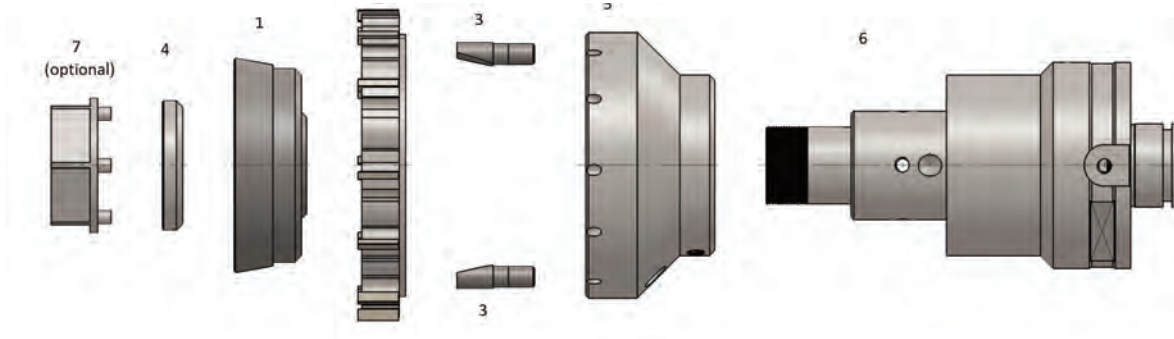

1) Assembly

With the drive pins (item 3) assembled, mount the flange (item 5) onto the mandrel (Item 6).

Assemble the cutting ring (item 2) so that the slot on the left side of the dimple is mounted onto the drive pins. Insert the conical ring (item 1).

Screw the ring nut (item 4) onto the mandrel and tighten manually, so that the conical ring makes contact with the cutting ring: the thread is left handed.

We recommend lubricating the thread and the conical surface of contact between the cutting ring and the conical ring with antifriction Molycote grease.

2) Adjustment procedure

Turn the ring nut slowly (using a pin spanner) checking the diameter setting of the cutting ring with a micrometer, paying attention that the drive pins are in traction, in the opposite direction to the cutting action of reamer.

When the required diameter is achieved, the tool is ready for use.

3) Disassembly

Unscrew the ring nut.

Remove the components from the mandrel.

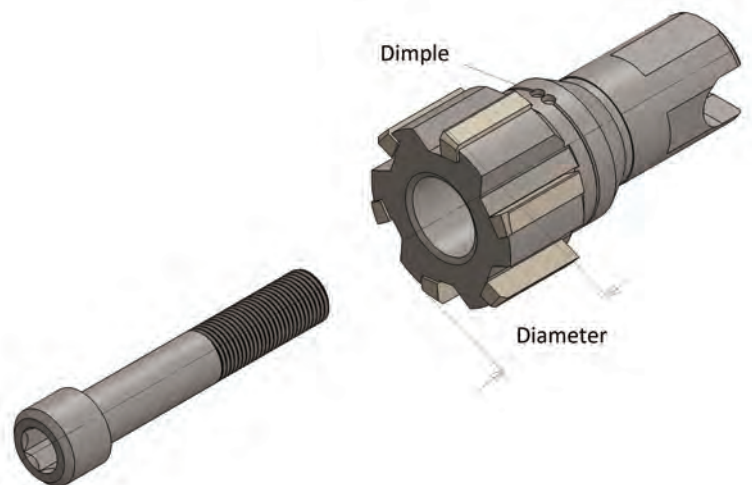
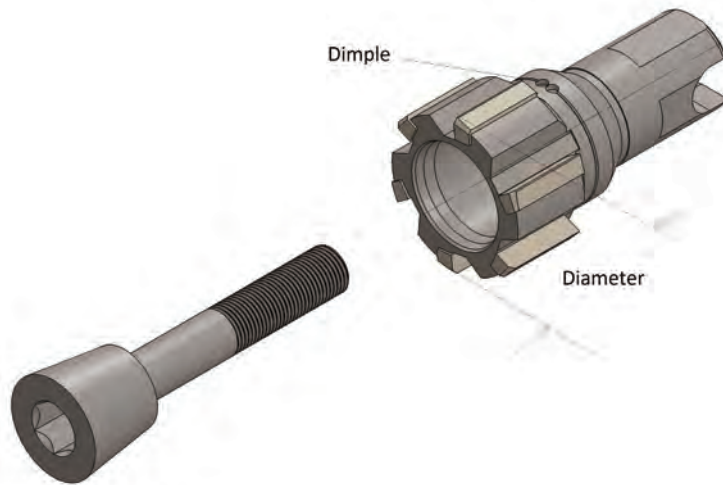

1) Diameter measurement

The diameter of the heads is measured with a micrometer. To avoid microchipping of the cutting edges, we would recommend the use of a comparator style micrometer with at least 2 μm resolution.

The cutting edges are of an asymmetric design with two cutting edges exactly 180° opposed to allow setting.

Measurement must be taken from the front of the cutting edges only.

2) Tolerance

Expandable reamer are manufactured to the middle of the tolerance.

Fixed reamer are manufactured at the $2/3$ of the tolerance.

3) Expanding heads adjustment

When the size reaches its lower tolerance the head can be adjusted to compensate for wear to the cutting edges.

This operation can be repeated several times until the surface finish of the hole deteriorates to an unacceptable level.

- Remedies to possible difficulties -

DEFECT	CAUSE	REMEDY
1) HOLE TOO LARGE	<ul style="list-style-type: none"> a) The reamer is running eccentric to the centre line of the machine spindle b) Excessive misalignment reamer works also at the end of the tapered part. c) Material build up on cutting edges d) The reamer diameter is too large 	<ul style="list-style-type: none"> a) Use the adjusted mandrel b) Rectify misalignment or use the adjusted mandrel c) Replace the coolant or change the cutting speed d) Use smaller reamer or regrind existing one
2) HOLE TOO SMALL	<ul style="list-style-type: none"> a) The reamer diameter is too small b) The reamer diameter is worn c) The coolant is not suitable d) Stock allowance too small e) The cutting speed is too low 	<ul style="list-style-type: none"> a) Use large reamer b) Expand, regrind or replace the reamer c) Replace the coolant d) Increase the stock allowance e) Increase the cutting speed
3) TAPERED HOLE smaller in entrance than in exit	<ul style="list-style-type: none"> a) Misalignment of the reamer respect to the holder 	<ul style="list-style-type: none"> a) Correct misalignment or use the adjusted mandrel
4) LIPPED HOLE larger in entrance than in exit	<ul style="list-style-type: none"> a) Misalignment of the reamer respect to hole 	<ul style="list-style-type: none"> a) Correct misalignment
5) BURR AT THE ENTRY OF THE HOLE	<ul style="list-style-type: none"> a) Excessive misalignment 	<ul style="list-style-type: none"> a) Correct misalignment or use the adjusted mandrel
6) THE HOLE IS NOT STRAIGHT	<ul style="list-style-type: none"> a) Concentricity and alignment error between the workpiece and the tool b) Asymmetrical cutting or angled surfaces. 	<ul style="list-style-type: none"> a) Correct misalignment or use the adjusted mandrel b) Create a chamfer on the lead-in
7) QUALITY OF THE WORK SURFACE UNSATISFACTORY	<ul style="list-style-type: none"> a) One cutting edge is chipped b) The lead-in is irregular c) Back taper on the cutting edges too great d) Excessive misalignment e) Cutting data not correct f) Poor chip evacuation 	<ul style="list-style-type: none"> a) Regrind the reamer b) Regrind the reamer c) Regrind the reamer d) Correct misalignment or use the adjusted mandrel e) Verify cutting data f) Verify coolant volume and pressure or use internal through tool coolant
8) THE REAMER CREATES EXCESSIVE TORQUE LOADING	<ul style="list-style-type: none"> a) Back taper on the cutting edges too small b) The radially ground land is too wide c) The coolant is not suitable 	<ul style="list-style-type: none"> a) Regrind the reamer b) Regrind the reamer c) Replace the coolant

Our technical department is available to assist in:

- 1) *Establishing optimum cutting data.*
- 2) *Verifying alignment problems.*
- 3) *Supply of correct regrinding data.*